



Single RAN BTS Site Solutions, Rel. SRAN 20B, Operating Documentation, Issue 02

Nokia AirScale Radio Description

DN09236379

Issue 27

Approval Date 2020-07-30

The information in this document applies solely to the hardware/software product ("Product") specified herein, and only as specified herein. Reference to "Nokia" later in this document shall mean the respective company within Nokia Group of Companies with whom you have entered into the Agreement (as defined below).

This document is intended for use by Nokia's customers ("You") only, and it may not be used except for the purposes defined in the agreement between You and Nokia ("Agreement") under which this document is distributed. No part of this document may be used, copied, reproduced, modified or transmitted in any form or means without the prior written permission of Nokia. If You have not entered into an Agreement applicable to the Product, or if that Agreement has expired or has been terminated, You may not use this document in any manner and You are obliged to return it to Nokia and destroy or delete any copies thereof.

The document has been prepared to be used by professional and properly trained personnel, and You assume full responsibility when using it. Nokia welcomes your comments as part of the process of continuous development and improvement of the documentation.

This document and its contents are provided as a convenience to You. Any information or statements concerning the suitability, capacity, fitness for purpose or performance of the Product are given solely on an "as is" and "as available" basis in this document, and Nokia reserves the right to change any such information and statements without notice. Nokia has made all reasonable efforts to ensure that the content of this document is adequate and free of material errors and omissions, and Nokia will correct errors that You identify in this document. Nokia's total liability for any errors in the document is strictly limited to the correction of such error(s). Nokia does not warrant that the use of the software in the Product will be uninterrupted or error-free.

NO WARRANTY OF ANY KIND, EITHER EXPRESS OR IMPLIED, INCLUDING BUT NOT LIMITED TO ANY WARRANTY OF AVAILABILITY, ACCURACY, RELIABILITY, TITLE, NON-INFRINGEMENT, MERCHANTABILITY OR FITNESS FOR A PARTICULAR PURPOSE, IS MADE IN RELATION TO THE CONTENT OF THIS DOCUMENT. IN NO EVENT WILL NOKIA BE LIABLE FOR ANY DAMAGES, INCLUDING BUT NOT LIMITED TO SPECIAL, DIRECT, INDIRECT, INCIDENTAL OR CONSEQUENTIAL OR ANY LOSSES, SUCH AS BUT NOT LIMITED TO LOSS OF PROFIT, REVENUE, BUSINESS INTERRUPTION, BUSINESS OPPORTUNITY OR DATA THAT MAY ARISE FROM THE USE OF THIS DOCUMENT OR THE INFORMATION IN IT, EVEN IN THE CASE OF ERRORS IN OR OMISSIONS FROM THIS DOCUMENT OR ITS CONTENT.

This document is Nokia proprietary and confidential information, which may not be distributed or disclosed to any third parties without the prior written consent of Nokia.

Nokia is a registered trademark of Nokia Corporation. Other product names mentioned in this document may be trademarks of their respective owners.

Copyright © 2020 Nokia. All rights reserved.



Important Notice on Product Safety

This product may present safety risks due to laser, electricity, heat, and other sources of danger.

Only trained and qualified personnel may install, operate, maintain or otherwise handle this product and only after having carefully read the safety information applicable to this product.

The safety information is provided in the Safety Information section in the "Legal, Safety and Environmental Information" part of this document or documentation set.

Nokia is continually striving to reduce the adverse environmental effects of its products and services. We would like to encourage you as our customers and users to join us in working towards a cleaner, safer environment. Please recycle product packaging and follow the recommendations for power use and proper disposal of our products and their components.

If you should have questions regarding our Environmental Policy or any of the environmental services we offer, please contact us at Nokia for any additional information.

Table of Contents

This document has 497 pages

	Summary of changes.....	26
1	Nokia AirScale Radio compliances.....	30
1.1	RSS-102 compliance.....	30
1.2	EU compliance.....	31
1.3	FCC Part 15 compliance.....	33
1.4	Compliance with EMC, RF and safety.....	33
2	RF performance.....	38
3	Nokia AirScale Radio support for BTS.....	39
4	List of Radio Units.....	40
5	Nokia AirScale Macro FDD-LTE Radios.....	47
5.1	Descriptions of RF modules.....	47
5.1.1	Nokia AirScale RFM 6T6R B1/n1 480 W (ARGA).....	47
5.1.2	Nokia AirScale RFM 6T6R B3/n3 480 W (AREA).....	53
5.1.3	Nokia AirScale RFM 6T6R B5 480 W (ARCA).....	59
5.1.4	Nokia AirScale RFM 6T6R B7 360 W (ARHA).....	65
5.1.5	Nokia AirScale RFM 6T6R B8 480 W (ARDA).....	71
5.1.6	Nokia AirScale RFM 6T6R B8 480 W (ARDB).....	77
5.1.7	Nokia AirScale RFM 6T6R B20 360 W (ARMA).....	83
5.1.8	Nokia AirScale RFM 6T6R B28/n28 360 W (ARPA).....	89
5.2	Descriptions of single band Remote Radio Heads.....	95
5.2.1	Nokia AirScale RRH 2T B32/75 120 W (AHSA).....	95
5.2.2	Nokia AirScale RRH 2T2R B3 120 W (FHEL).....	100
5.2.3	Nokia AirScale RRH 2T2R 900J 120 W (FHDI).....	106
5.2.4	Nokia AirScale RRH 2T2R B11 120 W (FHKA).....	111
5.2.5	Nokia AirScale RRH 2T2R B28 120 W (FHPD).....	116
5.2.6	Nokia AirScale RRH 2T2R 700 120 W (FHPG).....	122
5.2.7	Nokia AirScale RRH 2T4R B1/n1 120 W (AHGA).....	127
5.2.8	Nokia AirScale RRH 2T4R B1 120 W (AHGC).....	133
5.2.9	Nokia AirScale RRH 2T4R B3 160 W (AHEC).....	138
5.2.10	Nokia AirScale RRH 2T4R B3 160 W (AHED).....	144
5.2.11	Nokia AirScale RRH 2T4R B8 120 W (AHDA).....	149
5.2.12	Nokia AirScale RRH 2T4R B8/n8 160 W (AHDB).....	155
5.2.13	Nokia AirScale RRH 2T4R B20 120 W (AHMA).....	160
5.2.14	Nokia AirScale RRH 2T4R B28 120 W (AHPC).....	166
5.2.15	Nokia AirScale RRH 2T4R B28/n28 120 W (AHPD).....	171
5.2.16	Nokia AirScale RRH 2T4R B28 120 W (AHPE).....	176
5.2.17	Nokia AirScale RRH 4T4R B1/n1 320 W (AHGD).....	182
5.2.18	Nokia AirScale RRH 4T4R B3/n3 160 W (AHEB).....	187

5.2.19	Nokia AirScale RRH 4T4R B3 160 W (AHEH).....	193
5.2.20	Nokia AirScale RRH 4T4R B7/n7 160 W (AHHB).....	199
5.2.21	Nokia AirScale RRH 4T4R B5 160 W (AHCA).....	205
5.2.22	Nokia AirScale RRH 4T4R B26 200 W (AHCF).....	212
5.2.23	Nokia AirScale RRH 4T4R B26a 100 W (AHCC).....	217
5.2.24	Nokia AirScale RRH 4T4R B28/n28 320 W (AHPB).....	222
5.2.25	Nokia AirScale RRH 4T4R B30 100 W (AHNA).....	228
5.2.26	Nokia AirScale RRH 4T4R B66/n66 160 W (FRIJ).....	234
5.3	Descriptions of dual band radios.....	240
5.3.1	Nokia AirScale Dual RRH 2T4R B1/3 (n1/n3) 240 W (AHEGA).....	240
5.3.2	Nokia AirScale Dual RRH 2T2R B29/70 200 W (AHLJA).....	247
5.3.3	Nokia AirScale Dual RRH 4T4R B1/3 (n1/n3) 320 W (AHEGB).....	253
5.3.4	Nokia AirScale Dual RRH 4T4R B1/3 (n1/n3) 400 W (AHEGC).....	259
5.3.5	Nokia AirScale Dual RRH 4T4R B2/66a (n2/n66a) 320 W (AHFIC)	266
5.3.6	Nokia AirScale Dual RRH 4T4R B5/13 (n5) 160 W (AHBCA)....	273
5.3.7	Nokia AirScale Dual RRH 4T4R B5/13 320 W (AHBCC).....	279
5.3.8	Nokia AirScale Dual RRH 4T4R B5/28 (n5/n28) 320 W (AHPCA)...	286
5.3.9	Nokia AirScale Dual RRH 4T4R B5/29 240 W (AHBCB).....	292
5.3.10	Nokia AirScale Dual RRH 4T4R B8/28 (n8/n28) 480 W (AHPDA)...	298
5.3.11	Nokia AirScale Dual RRH 4T4R B12/14 320 W (AHLBA).....	303
5.3.12	Nokia AirScale Dual RRH 4T4R B12/71 240 W (AHLOA).....	310
5.3.13	Nokia AirScale Dual RRH 4T4R B13/71 (n71) 240 W (AHBOA)	317
5.3.14	Nokia AirScale Dual RRH 4T4R B25/66 320 W (AHFIB).....	323
5.3.15	Nokia AirScale Dual RRH 4T4R B25/66 (n25/n66) 480 W (AHFIG)	329
5.3.16	Nokia AirScale Dual RRH 4T4R B25/B66a (n25/n66a) 160 W	(AHFIA)..... 336
5.4	Description of triple band radios.....	342
5.4.1	Nokia AirScale Tri RRH 2T2R B8/20/28 240 W (AHPMDA).....	342
5.4.2	Nokia AirScale Tri RRH 2T4R B5/8/28 (n5/n8/n28) 240 W	(AHPCDB)..... 349
5.4.3	Nokia AirScale Tri RRH 2T4R B8/20/28 (n8/n20/n28) 240 W	(AHPMDB)..... 355
5.4.4	Nokia AirScale Tri RRH 4T4R B12/14/29 370 W (AHLBBA).....	361
6	Descriptions of Micro RRHs.....	368
6.1	Nokia AirScale Micro RRH 2T B46 UNII 1+3 1 W (AZRA).....	368
6.2	Nokia AirScale Micro RRH 2T B46 UNII 1+2+3 1 W (AZRB).....	373
6.3	Nokia AirScale Micro RRH 2T B46 UNII 1+2+3 1 W (AZRC)....	378
6.4	Nokia AirScale Micro 4T4R B1 20 W (AHGB).....	383
6.5	Nokia AirScale Micro 4T4R B3 20 W (AHEJ).....	387

6.6	Nokia AirScale Micro 4T4R B5 20 W (AHCE).....	392
6.7	Nokia AirScale Micro 4T4R B7 20 W (AHHA)	397
6.8	Nokia AirScale Micro 4T4R B13 20 W (AHBB)	401
6.9	Nokia AirScale Micro 4T4R B14 20 W (AHBC).....	406
6.10	Nokia AirScale Micro 4T4R B25 20 W (AHFB).....	410
6.11	Nokia AirScale Micro RRH 4T4R B41/n41 80 W (AWHHD).....	416
6.12	Nokia AirScale Micro RRH 4T4R B41/n41 80 W (AWHHF).....	420
6.13	Nokia AirScale Micro 4T4R B42 20 W (AZQD).....	425
6.14	Nokia AirScale Micro 4T4R B43 20 W (AZQR).....	430
6.15	Nokia AirScale Micro 4T4R B66 20 W (AHIB).....	434
6.16	Nokia AirScale Micro 4T4R CBRS 20 W (AZQC).....	440
7	Nokia AirScale Macro TD-LTE Radios.....	445
7.1	Nokia AirScale RRH 2T2R B40 120 W (AZND/AZNE).....	445
7.2	Nokia AirScale RRH 4T4R B40/n40 160 W (AZNA).....	451
7.3	Nokia AirScale RRH 4T4R B41/n41 160 W (AZHA).....	457
7.4	Nokia AirScale RRH 8T8R B40 240 W (AZNB).....	462
7.5	Nokia AirScale RRH 8T8R B40 240 W (AZNC).....	468
7.6	Nokia AirScale RRH 8T8R B42 160 W (AZQP).....	474
7.7	Nokia AirScale RRH 8T8R B42 240 W (AZQE).....	480
7.8	Nokia AirScale RRH 8T8R B42 240 W (AZQF).....	486
8	Nokia AirScale Radio Units sound power levels.....	493
9	Nokia AirScale Radios LED indicators.....	494
10	Avoiding Passive Intermodulation during RF Module and RRH operation.....	497

List of Figures

Figure 1	CE marking (EU R&TTE Directive 1999/5/EC).....	31
Figure 2	CE marking.....	32
Figure 3	RED Article 10.10-marking.....	32
Figure 4	ARGA interfaces.....	48
Figure 5	ARGA functional block diagram.....	50
Figure 6	AREA interfaces.....	54
Figure 7	AREA functional block diagram.....	56
Figure 8	ARCA interfaces.....	60
Figure 9	ARCA functional block diagram.....	62
Figure 10	ARHA interfaces.....	66
Figure 11	ARHA functional block diagram.....	68
Figure 12	ARDA interfaces.....	72
Figure 13	ARDA functional block diagram.....	73
Figure 14	ARDB interfaces.....	78
Figure 15	ARDB functional block diagram.....	80
Figure 16	ARMA interfaces.....	84
Figure 17	ARMA functional block diagram.....	86
Figure 18	ARPA interfaces.....	90
Figure 19	ARPA functional block diagram.....	92
Figure 20	AHSA interfaces.....	96
Figure 21	AHSA functional block diagram.....	97
Figure 22	FHEL interfaces.....	101
Figure 23	FHEL functional block diagram.....	102
Figure 24	FHDI interfaces.....	107
Figure 25	FHDI functional block diagram.....	108
Figure 26	FHKA interfaces.....	112
Figure 27	FHKA functional block diagram.....	113
Figure 28	FHPD interfaces.....	117
Figure 29	FHPD functional block diagram.....	118
Figure 30	FHPG interfaces.....	123
Figure 31	FHPG functional block diagram.....	124
Figure 32	AHGA interfaces.....	128
Figure 33	AHGA functional block diagram.....	130
Figure 34	AHGC interfaces.....	134
Figure 35	AHGC functional block diagram.....	135
Figure 36	AHEC interfaces.....	139
Figure 37	AHEC functional block diagram.....	141
Figure 38	AHED interfaces.....	145
Figure 39	AHED functional block diagram.....	146

Figure 40	AHDA interfaces.....	150
Figure 41	AHDA functional block diagram.....	152
Figure 42	AHDB interfaces.....	156
Figure 43	AHDB functional block diagram.....	157
Figure 44	AHMA interfaces.....	161
Figure 45	AHMA functional block diagram.....	163
Figure 46	AHPC interfaces.....	167
Figure 47	AHPC functional block diagram.....	168
Figure 48	AHPD interfaces.....	172
Figure 49	AHPD functional block diagram.....	173
Figure 50	AHPE interfaces.....	177
Figure 51	AHPE functional block diagram.....	179
Figure 52	AHGD interfaces.....	183
Figure 53	AHGD functional block diagram.....	184
Figure 54	AHEB interfaces.....	188
Figure 55	AHEB functional block diagram.....	189
Figure 56	AHEH interfaces.....	194
Figure 57	AHEH functional block diagram.....	196
Figure 58	AHHB interfaces.....	200
Figure 59	AHHB functional block diagram.....	202
Figure 60	AHCA interfaces.....	206
Figure 61	AHCA functional block diagram.....	208
Figure 62	AHCF interfaces.....	213
Figure 63	AHCF functional block diagram.....	214
Figure 64	AHCC interfaces.....	218
Figure 65	AHCC functional block diagram.....	219
Figure 66	AHPB interfaces.....	223
Figure 67	AHPB functional block diagram.....	225
Figure 68	AHNA interfaces.....	229
Figure 69	AHNA functional block diagram.....	230
Figure 70	FRIJ interfaces.....	235
Figure 71	FRIJ functional block diagram.....	236
Figure 72	AHEGA interfaces.....	242
Figure 73	AHEGA functional block diagram.....	243
Figure 74	AHLJA interfaces.....	249
Figure 75	AHLJA functional block diagram.....	250
Figure 76	AHEGB interfaces.....	254
Figure 77	AHEGB functional block diagram.....	256
Figure 78	AHEGC interfaces.....	261
Figure 79	AHEGC functional block diagram.....	262

Figure 80	AHFIC interfaces.....	267
Figure 81	AHFIC functional block diagram.....	269
Figure 82	AHBCA interfaces.....	274
Figure 83	AHBCA functional block diagram.....	276
Figure 84	AHBCC interfaces.....	281
Figure 85	AHBCC functional block diagram.....	282
Figure 86	AHPCA interfaces.....	287
Figure 87	AHPCA functional block diagram.....	289
Figure 88	AHBCB interfaces.....	293
Figure 89	AHBCB functional block diagram.....	295
Figure 90	AHPDA interfaces.....	299
Figure 91	AHPDA functional block diagram.....	301
Figure 92	AHLBA interfaces.....	304
Figure 93	AHLBA functional block diagram.....	306
Figure 94	AHLOA interfaces (Style A).....	311
Figure 95	AHLOA interfaces (Style B).....	312
Figure 96	AHLOA functional block diagram.....	314
Figure 97	AHBOA interfaces.....	318
Figure 98	AHBOA functional block diagram.....	320
Figure 99	AHFIB interfaces.....	324
Figure 100	AHFIB functional block diagram.....	326
Figure 101	AHFIG interfaces.....	331
Figure 102	AHFIG functional block diagram.....	332
Figure 103	AHFIA interfaces.....	337
Figure 104	AHFIA functional block diagram.....	338
Figure 105	AHPMDA interfaces.....	344
Figure 106	AHPMDA functional block diagram.....	345
Figure 107	AHPCDB interfaces.....	351
Figure 108	AHPCDB functional block diagram.....	352
Figure 109	AHPMDB interfaces.....	357
Figure 110	AHPMDB functional block diagram.....	358
Figure 111	AHLBBA interfaces.....	363
Figure 112	AHLBBA functional block diagram.....	364
Figure 113	AZRA interfaces.....	369
Figure 114	AZRA functional block diagram.....	370
Figure 115	AZRB interfaces.....	374
Figure 116	AZRB functional block diagram.....	375
Figure 117	AZRC interfaces.....	379
Figure 118	AZRC functional block diagram.....	380
Figure 119	AHGB interfaces.....	384

Figure 120	AHGB functional block diagram.....	385
Figure 121	AHEJ interfaces.....	388
Figure 122	AHEJ functional block diagram.....	389
Figure 123	AHCE interfaces.....	393
Figure 124	AHCE functional block diagram.....	394
Figure 125	AHHA interfaces.....	398
Figure 126	AHHA functional block diagram.....	399
Figure 127	AHBB interfaces.....	402
Figure 128	AHBB functional block diagram.....	403
Figure 129	AHBC interfaces.....	407
Figure 130	AHBC functional block diagram.....	408
Figure 131	AHFB interfaces.....	411
Figure 132	AHFB functional block diagram.....	413
Figure 133	AWHHD interfaces.....	417
Figure 134	AWHHD functional block diagram.....	418
Figure 135	AWHHF interfaces.....	421
Figure 136	AWHHF functional block diagram.....	423
Figure 137	AZQD interfaces.....	426
Figure 138	AZQD functional block diagram.....	427
Figure 139	AZQR interfaces.....	431
Figure 140	AZQR functional block diagram.....	432
Figure 141	AHIB interfaces.....	435
Figure 142	AHIB functional block diagram.....	437
Figure 143	AZQC interfaces.....	441
Figure 144	AZQC functional block diagram.....	442
Figure 145	AZND interfaces.....	446
Figure 146	AZNE interfaces.....	446
Figure 147	AZND/AZNE functional block diagram.....	447
Figure 148	AZNA interfaces.....	452
Figure 149	AZNA (with MHA) variants A.101, A.102, all B-variants; functional block diagram.....	453
Figure 150	AZNA (without MHA) variants A.203 onwards; functional block diagram.....	454
Figure 151	AZHA interfaces.....	458
Figure 152	AZHA functional block diagram.....	459
Figure 153	AZNB interfaces.....	463
Figure 154	AZNB functional block diagram.....	465
Figure 155	AZNC interfaces.....	469
Figure 156	AZNC functional block diagram.....	471
Figure 157	AZQP interfaces.....	475
Figure 158	AZQP functional block diagram.....	477

Figure 159	AZQE carrier configuration for iBW from over 110 MHz to 140 MHz.....	480
Figure 160	AZQE interfaces.....	481
Figure 161	AZQE functional block diagram.....	483
Figure 162	AZQF carrier configuration for iBW from over 110 MHz to 140 MHz.....	487
Figure 163	AZQF interfaces.....	488
Figure 164	AZQF functional block diagram.....	489

List of Tables

Table 1	RSS-102 Issue 5 Compliance boundaries (m) for general public levels	30
Table 2	RSS-102 Issue 5 Compliance boundaries (m) for occupational levels... 30	
Table 3	RF Modules.....	40
Table 4	Single band Remote Radio Heads.....	41
Table 5	Dual band Remote Radio Heads.....	42
Table 6	Triple band Remote Radio Heads.....	44
Table 7	Micro Remote Radio Heads.....	44
Table 8	TD-LTE Remote Radio Heads.....	45
Table 9	ARGA functional specification.....	47
Table 10	ARGA interfaces.....	48
Table 11	ARGA ALD support.....	49
Table 12	ARGA electrical specifications.....	50
Table 13	ARGA TX output power tolerance.....	51
Table 14	ARGA power consumption in LTE mode.....	51
Table 15	Recommended ARGA power reduction in 256 QAM mode.....	51
Table 16	ARGA dimensions and weight.....	52
Table 17	ARGA environmental specifications.....	52
Table 18	AREA functional specification.....	53
Table 19	AREA interfaces.....	55
Table 20	AREA ALD support.....	55
Table 21	AREA electrical specifications.....	56
Table 22	AREA TX output power tolerance.....	57
Table 23	AREA power consumption in LTE mode.....	57
Table 24	Recommended AREA power reduction in 256 QAM.....	57
Table 25	AREA dimensions and weight.....	58
Table 26	AREA environmental specifications.....	58
Table 27	ARCA functional specification.....	59
Table 28	ARCA interfaces.....	61
Table 29	ARCA ALD support.....	61
Table 30	ARCA electrical specifications.....	62
Table 31	ARCA TX output power tolerance.....	63
Table 32	ARCA power consumption in LTE mode.....	63
Table 33	Recommended ARCA power reduction in 256 QAM mode.....	63
Table 34	ARCA dimensions and weight.....	64
Table 35	ARCA environmental specifications.....	64
Table 36	ARHA functional specification.....	65
Table 37	ARHA interfaces.....	66

Table 38	ARHA ALD support.....	67
Table 39	ARHA electrical specifications.....	68
Table 40	ARHA TX output power tolerance.....	69
Table 41	Recommended ARHA power reduction in 256 QAM mode.....	69
Table 42	ARHA dimensions and weight.....	70
Table 43	ARHA environmental specifications.....	70
Table 44	ARDA functional specification.....	71
Table 45	ARDA interfaces.....	72
Table 46	ARDA ALD support.....	73
Table 47	ARDA electrical specifications.....	74
Table 48	ARDA TX output power tolerance.....	74
Table 49	ARDA power consumption in LTE mode.....	74
Table 50	Recommended ARDA power reduction in 256 QAM mode.....	75
Table 51	ARDA dimensions and weight.....	76
Table 52	ARDA environmental specifications.....	76
Table 53	ARDB functional specification.....	77
Table 54	ARDB interfaces.....	78
Table 55	ARDB ALD support.....	79
Table 56	ARDB electrical specifications.....	80
Table 57	ARDB TX output power tolerance.....	81
Table 58	ARDB power consumption in LTE mode.....	81
Table 59	Recommended ARDB power reduction in 256 QAM mode.....	81
Table 60	ARDB dimensions and weight.....	82
Table 61	ARDB environmental specifications.....	82
Table 62	ARMA functional specification.....	83
Table 63	ARMA interfaces.....	84
Table 64	ARMA ALD support.....	85
Table 65	ARMA electrical specifications.....	86
Table 66	ARMA TX output power tolerance.....	87
Table 67	Recommended ARMA power reduction in 256 QAM mode.....	87
Table 68	ARMA dimensions and weight.....	88
Table 69	ARMA environmental specifications.....	88
Table 70	ARPA functional specification.....	89
Table 71	ARPA interfaces.....	90
Table 72	ARPA ALD support.....	91
Table 73	ARPA electrical specifications.....	92
Table 74	ARPA TX output power tolerance.....	93
Table 75	Recommended ARPA power reduction in 256 QAM mode.....	93
Table 76	ARPA dimensions and weight.....	94
Table 77	ARPA environmental specifications.....	94

Table 78	AHSA functional specification.....	95
Table 79	AHSA interfaces.....	96
Table 80	AHSA ALD support.....	97
Table 81	AHSA electrical specifications.....	97
Table 82	AHSA power consumption in LTE mode.....	98
Table 83	AHSA dimensions and weight.....	99
Table 84	AHSA environmental specifications.....	99
Table 85	FHEL functional specification.....	100
Table 86	FHEL interfaces.....	101
Table 87	FHEL ALD support.....	102
Table 88	FHEL electrical specifications.....	102
Table 89	FHEL power consumption.....	103
Table 90	FHEL power reduction in 256 QAM.....	103
Table 91	FHEL dimensions and weight.....	104
Table 92	FHEL environmental specifications.....	105
Table 93	FHDI functional specification.....	106
Table 94	FHDI interfaces.....	107
Table 95	FHDI ALD support.....	108
Table 96	FHDI electrical specifications.....	108
Table 97	FHDI dimensions and weight.....	109
Table 98	FHDI environmental specifications.....	110
Table 99	FHKA functional specification.....	111
Table 100	FHKA interfaces.....	112
Table 101	FHKA ALD support.....	113
Table 102	FHKA electrical specifications.....	113
Table 103	FHKA power consumption in LTE mode.....	114
Table 104	FHKA dimensions and weight.....	115
Table 105	FHKA environmental specifications.....	115
Table 106	FHPD functional specification.....	116
Table 107	FHPD interfaces.....	117
Table 108	FHPD ALD support.....	118
Table 109	FHPD electrical specifications.....	119
Table 110	FHPD power consumption in LTE mode.....	119
Table 111	FHPD power reduction in 256 QAM.....	119
Table 112	FHPD dimensions and weight.....	120
Table 113	FHPD environmental specifications.....	121
Table 114	FHPG functional specification.....	122
Table 115	FHPG interfaces.....	123
Table 116	FHPG ALD support.....	124
Table 117	FHPG electrical specifications.....	124

Table 118	FHPG power consumption in LTE mode.....	125
Table 119	FHPG dimensions and weight.....	126
Table 120	FHPG environmental specifications.....	126
Table 121	AHGA functional specification.....	127
Table 122	AHGA interfaces.....	128
Table 123	AHGA ALD support.....	129
Table 124	AHGA electrical specifications.....	130
Table 125	AHGA power consumption in LTE mode.....	131
Table 126	AHGA dimensions and weight.....	132
Table 127	AHGA environmental specifications.....	132
Table 128	AHGC functional specification.....	133
Table 129	AHGC interfaces.....	134
Table 130	AHGC ALD support.....	135
Table 131	AHGC electrical specifications.....	135
Table 132	AHGC power consumption in LTE mode.....	136
Table 133	AHGC dimensions and weight.....	137
Table 134	AHGC environmental specifications.....	137
Table 135	AHEC functional specification.....	138
Table 136	AHEC interfaces.....	139
Table 137	AHEC ALD support.....	140
Table 138	AHEC electrical specifications.....	141
Table 139	AHEC power consumption in LTE mode.....	142
Table 140	AHEC dimensions and weight.....	143
Table 141	AHEC environmental specifications.....	143
Table 142	AHED functional specification.....	144
Table 143	AHED interfaces.....	145
Table 144	AHED ALD support.....	146
Table 145	AHED electrical specifications.....	146
Table 146	AHED power consumption in LTE mode.....	147
Table 147	AHED dimensions and weight.....	148
Table 148	AHED environmental specifications.....	148
Table 149	AHDA functional specification.....	149
Table 150	AHDA interfaces.....	150
Table 151	AHDA ALD support.....	151
Table 152	AHDA electrical specifications.....	152
Table 153	AHDA power consumption in LTE mode.....	153
Table 154	AHDA power reduction.....	153
Table 155	AHDA dimensions and weight.....	154
Table 156	AHDA environmental specifications.....	154
Table 157	AHDB functional specification.....	155

Table 158	AHDB interfaces.....	156
Table 159	AHDB ALD support.....	157
Table 160	AHDB electrical specifications.....	157
Table 161	AHDB power consumption in LTE mode.....	158
Table 162	AHDB dimensions and weight.....	159
Table 163	AHDB environmental specifications.....	159
Table 164	AHMA functional specification.....	160
Table 165	AHMA interfaces.....	161
Table 166	AHMA ALD support.....	162
Table 167	AHMA electrical specifications.....	163
Table 168	AHMA power consumption in LTE mode.....	164
Table 169	AHMA dimensions and weight.....	165
Table 170	AHMA environmental specifications.....	165
Table 171	AHPC functional specification.....	166
Table 172	AHPC interfaces.....	167
Table 173	AHPC ALD support.....	168
Table 174	AHPC electrical specifications.....	168
Table 175	AHPC power consumption in LTE mode.....	169
Table 176	AHPC dimensions and weight.....	170
Table 177	AHPC environmental specifications.....	170
Table 178	AHPD functional specification.....	171
Table 179	AHPD interfaces.....	172
Table 180	AHPD ALD support.....	173
Table 181	AHPD electrical specifications.....	174
Table 182	AHPD power consumption in LTE mode.....	174
Table 183	AHPD dimensions and weight.....	175
Table 184	AHPD environmental specifications.....	176
Table 185	AHPE functional specification.....	176
Table 186	AHPE interfaces.....	178
Table 187	AHPE ALD support.....	178
Table 188	AHPE electrical specifications.....	179
Table 189	AHPE power consumption in LTE mode.....	180
Table 190	AHPE power reduction in 256 QAM.....	180
Table 191	AHPE dimensions and weight.....	181
Table 192	AHPE environmental specifications.....	181
Table 193	AHGD functional specification.....	182
Table 194	AHGD interfaces.....	183
Table 195	AHGD ALD support.....	184
Table 196	AHGD electrical specifications.....	185
Table 197	Recommended AHGD power reduction per band, in 256 QAM.....	185

Table 198	AHGD dimensions and weight.....	186
Table 199	AHGD environmental specifications.....	186
Table 200	AHEB functional specification.....	187
Table 201	AHEB interfaces.....	188
Table 202	AHEB ALD support.....	189
Table 203	AHEB electrical specifications.....	189
Table 204	AHEB power consumption in LTE mode.....	190
Table 205	AHEB power reduction in 256 QAM.....	190
Table 206	AHEB dimensions and weight.....	192
Table 207	AHEB environmental specifications.....	192
Table 208	AHEH functional specification.....	193
Table 209	AHEH interfaces.....	194
Table 210	AHEH ALD support.....	195
Table 211	AHEH electrical specifications.....	196
Table 212	AHEH power consumption in LTE mode.....	197
Table 213	AHEH power reduction in 256 QAM.....	197
Table 214	AHEH dimensions and weight.....	198
Table 215	AHEH environmental specifications.....	198
Table 216	AHHB functional specification.....	199
Table 217	AHHB interfaces.....	200
Table 218	AHHB ALD support.....	201
Table 219	AHHB electrical specifications.....	202
Table 220	AHHB power consumption in LTE mode.....	203
Table 221	Recommended AHHB power reduction in 256 QAM.....	203
Table 222	AHHB dimensions and weight.....	204
Table 223	AHHB environmental specifications.....	204
Table 224	AHCA functional specification.....	205
Table 225	AHCA interfaces.....	207
Table 226	AHCA ALD support.....	207
Table 227	AHCA electrical specifications.....	208
Table 228	AHCA power consumption in LTE mode.....	209
Table 229	Recommended AHCA power reduction in 256 QAM.....	209
Table 230	AHCA dimensions and weight.....	210
Table 231	AHCA environmental specifications.....	211
Table 232	AHCF functional specification.....	212
Table 233	AHCF interfaces.....	213
Table 234	AHCF ALD support.....	214
Table 235	AHCF electrical specifications.....	214
Table 236	AHCF dimensions and weight.....	216
Table 237	AHCF environmental specifications.....	216

Table 238	AHCC functional specification.....	217
Table 239	AHCC interfaces.....	218
Table 240	AHCC ALD support.....	219
Table 241	AHCC electrical specifications.....	219
Table 242	AHCC TX output power tolerance.....	220
Table 243	AHCC power consumption in LTE mode.....	220
Table 244	AHCC power reduction in 256 QAM	220
Table 245	AHCC dimensions and weight.....	221
Table 246	AHCC environmental specifications.....	222
Table 247	AHPB functional specification.....	223
Table 248	AHPB interfaces.....	224
Table 249	AHPB ALD support.....	224
Table 250	AHPB electrical specifications.....	225
Table 251	AHPB power consumption in LTE mode.....	226
Table 252	AHPB power reduction in 256 QAM (carrier spacing over 100 MHz)	226
Table 253	AHPB dimensions and weight.....	227
Table 254	AHPB environmental specifications.....	227
Table 255	AHNA functional specification.....	228
Table 256	AHNA interfaces.....	229
Table 257	AHNA ALD support.....	230
Table 258	AHNA electrical specifications.....	230
Table 259	AHNA power consumption in LTE mode.....	231
Table 260	AHNA power reduction in 256QAM.....	231
Table 261	AHNA dimensions and weight.....	232
Table 262	AHNA environmental specifications.....	233
Table 263	FRIJ functional specification.....	234
Table 264	FRIJ interfaces.....	235
Table 265	FRIJ ALD support.....	236
Table 266	FRIJ electrical specifications.....	236
Table 267	FRIJ power consumption.....	237
Table 268	FRIJ power reduction in 256 QAM.....	237
Table 269	FRIJ dimensions and weight.....	238
Table 270	FRIJ environmental specifications.....	239
Table 271	AHEGA functional specification.....	240
Table 272	AHEGA interfaces.....	242
Table 273	AHEGA ALD support.....	243
Table 274	AHEGA electrical specifications.....	243
Table 275	AHEGA power consumption in LTE mode.....	244
Table 276	Recommended AHEGA power reduction per band, in 256 QAM.....	245
Table 277	AHEGA dimensions and weight.....	246

Table 278	AHEGA environmental specifications.....	246
Table 279	AHLJA functional specification.....	247
Table 280	AHLJA interfaces.....	249
Table 281	AHLJA ALD support.....	250
Table 282	AHLJA electrical specifications.....	250
Table 283	Recommended AHLJA power reduction per band, in 256 QAM.....	251
Table 284	AHLJA dimensions and weight.....	252
Table 285	AHLJA environmental specifications.....	252
Table 286	AHEGB functional specification.....	253
Table 287	AHEGB interfaces.....	254
Table 288	AHEGB ALD support.....	255
Table 289	AHEGB electrical specifications.....	256
Table 290	AHEGB power consumption in LTE mode.....	257
Table 291	Recommended AHEGB power reduction per band, in 256 QAM.....	257
Table 292	AHEGB dimensions and weight.....	258
Table 293	AHEGB environmental specifications.....	258
Table 294	AHEGC functional specification.....	259
Table 295	AHEGC interfaces.....	261
Table 296	AHEGC ALD support.....	262
Table 297	AHEGC electrical specifications.....	262
Table 298	AHEGC power consumption in LTE mode.....	263
Table 299	Recommended AHEGC power reduction per band, in 256 QAM.....	264
Table 300	AHEGC dimensions and weight.....	265
Table 301	AHEGC environmental specifications.....	265
Table 302	AHFIC functional specification.....	266
Table 303	AHFIC interfaces.....	268
Table 304	AHFIC ALD support.....	268
Table 305	AHFIC electrical specifications.....	270
Table 306	AHFIC power consumption.....	270
Table 307	Recommended AHFIC power reduction per band, in 256 QAM.....	271
Table 308	AHFIC dimensions and weight.....	272
Table 309	AHFIC environmental specifications.....	272
Table 310	AHBCA functional specification.....	273
Table 311	AHBCA interfaces.....	274
Table 312	AHBCA ALD support.....	275
Table 313	AHBCA electrical specifications.....	276
Table 314	AHBCA power consumption in LTE mode.....	277
Table 315	Recommended AHBCA power reduction in 256 QAM (carrier spacing over 100 MHz)	277
Table 316	AHBCA dimensions and weight.....	278
Table 317	AHBCA environmental specifications.....	278

Table 318	AHBCC functional specification.....	279
Table 319	AHBCC interfaces.....	281
Table 320	AHBCC ALD support.....	282
Table 321	AHBCC electrical specifications.....	282
Table 322	AHBCC power consumption in LTE mode.....	283
Table 323	Recommended AHBCC power reduction per band, in 256 QAM (carrier spacing over 100 MHz).....	284
Table 324	AHBCC dimensions and weight.....	285
Table 325	AHBCC environmental specifications.....	285
Table 326	AHPCA functional specification.....	286
Table 327	AHPCA interfaces.....	288
Table 328	AHPCA ALD support.....	288
Table 329	AHPCA electrical specifications.....	289
Table 330	Recommended AHPCA power reduction in 256 QAM.....	289
Table 331	AHPCA dimensions and weight.....	290
Table 332	AHPCA environmental specifications.....	291
Table 333	AHBCB functional specification.....	292
Table 334	AHBCB interfaces.....	293
Table 335	AHBCB ALD support.....	294
Table 336	AHBCB electrical specifications.....	295
Table 337	AHBCB dimensions and weight.....	296
Table 338	AHBCB environmental specifications.....	297
Table 339	AHPDA functional specification.....	298
Table 340	AHPDA interfaces.....	299
Table 341	AHPDA ALD support.....	300
Table 342	AHPDA electrical specifications.....	301
Table 343	AHPDA dimensions and weight.....	302
Table 344	AHPDA environmental specifications.....	302
Table 345	AHLBA functional specification.....	303
Table 346	AHLBA interfaces.....	305
Table 347	AHLBA ALD support.....	305
Table 348	AHLBA electrical specifications.....	306
Table 349	AHLBA power consumption in LTE mode.....	307
Table 350	Recommended AHLBA power reduction in 256 QAM (carrier spacing over 100 MHz).....	308
Table 351	AHLBA dimensions and weight.....	309
Table 352	AHLBA environmental specifications.....	309
Table 353	AHLOA functional specification.....	310
Table 354	AHLOA interfaces.....	312
Table 355	AHLOA ALD support.....	313
Table 356	AHLOA electrical specifications.....	314

Table 357	Recommended AHLOA power reduction in 256 QAM (carrier spacing over 100 MHz).....	315
Table 358	AHLOA dimensions and weight.....	316
Table 359	AHLOA environmental specifications.....	316
Table 360	AHBOA functional specification.....	317
Table 361	AHBOA interfaces.....	318
Table 362	AHBOA ALD support.....	319
Table 363	AHBOA electrical specifications.....	320
Table 364	Recommended AHBOA power reduction in 256 QAM.....	321
Table 365	AHBOA dimensions and weight.....	322
Table 366	AHBOA environmental specifications.....	322
Table 367	AHFIB functional specification.....	323
Table 368	AHFIB interfaces.....	325
Table 369	AHFIB ALD support.....	325
Table 370	AHFIB electrical specifications.....	326
Table 371	AHFIB power consumption in LTE mode.....	327
Table 372	Recommended AHFIB power reduction per band, in 256 QAM.....	327
Table 373	AHFIB dimensions and weight.....	328
Table 374	AHFIB environmental specifications.....	328
Table 375	AHFIG functional specification.....	329
Table 376	AHFIG interfaces.....	331
Table 377	AHFIG ALD support.....	332
Table 378	AHFIG electrical specifications.....	332
Table 379	AHFIG power consumption in LTE mode.....	333
Table 380	Recommended AHFIG power reduction per band, in 256 QAM.....	334
Table 381	AHFIG dimensions and weight.....	334
Table 382	AHFIG environmental specifications.....	335
Table 383	AHFIA functional specification.....	336
Table 384	AHFIA interfaces.....	337
Table 385	AHFIA ALD support.....	338
Table 386	AHFIA electrical specifications.....	338
Table 387	AHFIA power consumption in LTE mode.....	339
Table 388	Recommended AHFIA power reduction per band, in 256 QAM.....	340
Table 389	AHFIA dimensions and weight.....	341
Table 390	AHFIA environmental specifications.....	341
Table 391	AHPMDA functional specification.....	342
Table 392	AHPMDA interfaces.....	344
Table 393	AHPMDA ALD support.....	345
Table 394	AHPMDA electrical specifications.....	345
Table 395	AHPMDA power consumption in LTE mode.....	346

Table 396	Recommended AHPMDA power reduction in 256 QAM (carrier spacing over 100 MHz).....	347
Table 397	AHPMDA dimensions and weight.....	348
Table 398	AHPMDA environmental specifications.....	348
Table 399	AHPCDB functional specification.....	349
Table 400	AHPCDB interfaces.....	351
Table 401	AHPCDB ALD support.....	352
Table 402	AHPCDB electrical specifications.....	353
Table 403	AHPCDB dimensions and weight.....	354
Table 404	AHPCDB environmental specifications.....	354
Table 405	AHPMDB functional specification.....	355
Table 406	AHPMDB interfaces.....	357
Table 407	AHPMDB ALD support.....	358
Table 408	AHPMDB electrical specifications.....	359
Table 409	Recommended AHPMDB power reduction per band, in 256 QAM (carrier spacing over 100 MHz).....	359
Table 410	AHPMDB dimensions and weight.....	360
Table 411	AHPMDB environmental specifications.....	360
Table 412	AHLBBA functional specification.....	361
Table 413	AHLBBA interfaces.....	363
Table 414	AHLBBA ALD support.....	364
Table 415	AHLBBA electrical specifications.....	365
Table 416	Recommended AHLBBA power reduction in 256 QAM (carrier spacing over 100 MHz).....	365
Table 417	AHLBBA dimensions and weight.....	366
Table 418	AHLBBA environmental specifications.....	366
Table 419	AZRA functional specification.....	368
Table 420	AZRA interfaces.....	369
Table 421	AZRA electrical specifications.....	370
Table 422	AZRA power consumption in LTE mode.....	371
Table 423	AZRA dimensions and weight.....	372
Table 424	AZRA environmental specifications.....	372
Table 425	AZRB functional specification.....	373
Table 426	AZRB interfaces.....	374
Table 427	AZRB electrical specifications.....	375
Table 428	AZRB power consumption in LTE mode.....	376
Table 429	AZRB dimensions and weight.....	377
Table 430	AZRB environmental specifications.....	377
Table 431	AZRC functional specification.....	378
Table 432	AZRC interfaces.....	379
Table 433	AZRC electrical specifications.....	380

Table 434	AZRC power consumption in LTE mode.....	381
Table 435	AZRC dimensions and weight.....	382
Table 436	AZRC environmental specifications.....	382
Table 437	AHGB functional specification.....	383
Table 438	AHGB interfaces.....	384
Table 439	AHGB electrical specifications.....	385
Table 440	AHGB dimensions and weight.....	386
Table 441	AHGB environmental specifications.....	386
Table 442	AHEJ functional specification.....	387
Table 443	AHEJ interfaces.....	388
Table 444	AHEJ electrical specifications.....	390
Table 445	AHEJ power consumption in LTE mode.....	390
Table 446	AHEJ dimensions and weight.....	391
Table 447	AHEJ environmental specifications.....	391
Table 448	AHCE functional specification.....	392
Table 449	AHCE interfaces.....	393
Table 450	AHCE electrical specifications.....	395
Table 451	AHCE dimensions and weight.....	396
Table 452	AHCE environmental specifications.....	396
Table 453	AHHA functional specification.....	397
Table 454	AHHA interfaces.....	398
Table 455	AHHA electrical specifications.....	399
Table 456	AHHA dimensions and weight.....	400
Table 457	AHHA environmental specifications.....	400
Table 458	AHBB functional specification.....	401
Table 459	AHBB interfaces.....	402
Table 460	AHBB electrical specifications.....	404
Table 461	AHBB dimensions and weight.....	405
Table 462	AHBB environmental specifications.....	405
Table 463	AHBC functional specification.....	406
Table 464	AHBC interfaces.....	407
Table 465	AHBC electrical specifications.....	408
Table 466	AHBC dimensions and weight.....	409
Table 467	AHBC environmental specifications.....	410
Table 468	AHFB functional specification.....	410
Table 469	AHFB interfaces.....	412
Table 470	AHFB electrical specifications.....	413
Table 471	AHFB power consumption in LTE mode.....	414
Table 472	AHFB dimensions and weight.....	415
Table 473	AHFB environmental specifications.....	415

Table 474	AWHHD functional specification.....	416
Table 475	AWHHD interfaces.....	417
Table 476	AWHHD ALD support.....	418
Table 477	AWHHD electrical specifications.....	418
Table 478	AWHHD dimensions and weight.....	419
Table 479	AWHHD environmental specifications.....	420
Table 480	AWHHF functional specification.....	420
Table 481	AWHHF interfaces.....	422
Table 482	AWHHF ALD support.....	422
Table 483	AWHHF electrical specifications.....	423
Table 484	AWHHF dimensions and weight.....	424
Table 485	AWHHF environmental specifications.....	424
Table 486	AZQD functional specification.....	425
Table 487	AZQD interfaces.....	426
Table 488	AZQD electrical specifications.....	427
Table 489	AZQD dimensions and weight.....	429
Table 490	AZQD environmental specifications.....	429
Table 491	AZQR functional specification.....	430
Table 492	AZQR interfaces.....	431
Table 493	AZQR electrical specifications.....	432
Table 494	AZQR dimensions and weight.....	433
Table 495	AZQR environmental specifications.....	434
Table 496	AHIB functional specification.....	434
Table 497	AHIB interfaces.....	435
Table 498	AHIB electrical specifications.....	437
Table 499	AHIB power consumption in LTE mode.....	438
Table 500	AHIB dimensions and weight.....	439
Table 501	AHIB environmental specifications.....	439
Table 502	AZQC functional specification.....	440
Table 503	AZQC interfaces.....	441
Table 504	AZQC electrical specifications.....	442
Table 505	AZQC power consumption in LTE mode.....	443
Table 506	AZQC dimensions and weight.....	444
Table 507	AZQC environmental specifications.....	444
Table 508	AZND/AZNE functional specification.....	445
Table 509	AZND/AZNE interfaces.....	446
Table 510	AZND/AZNE electrical specifications.....	447
Table 511	AZND power consumption in LTE mode.....	448
Table 512	AZNE power consumption.....	449
Table 513	Recommended AZND/AZNE power reduction in 256 QAM.....	449

Table 514	AZND/AZNE dimensions and weight.....	450
Table 515	AZND/AZNE environmental specifications.....	450
Table 516	AZNA functional specification.....	451
Table 517	AZNA interfaces.....	452
Table 518	AZNA ALD support.....	453
Table 519	AZNA electrical specifications.....	454
Table 520	AZNA power consumption in LTE mode.....	455
Table 521	Recommended AZNA power reduction in 256 QAM.....	455
Table 522	AZNA dimensions and weight.....	456
Table 523	AZNA environmental specifications.....	456
Table 524	AZHA functional specification.....	457
Table 525	AZHA interfaces.....	458
Table 526	AZHA ALD support.....	459
Table 527	AZHA electrical specifications.....	459
Table 528	AZHA power consumption in LTE mode.....	460
Table 529	AZHA dimensions and weight.....	461
Table 530	AZHA environmental specifications.....	462
Table 531	AZNB functional specification.....	462
Table 532	AZNB interfaces.....	463
Table 533	AZNB ALD support.....	464
Table 534	AZNB electrical specifications.....	465
Table 535	AZNB power consumption in LTE mode.....	466
Table 536	Recommended AZNB power reduction in 256 QAM.....	466
Table 537	AZNB dimensions and weight.....	467
Table 538	AZNB environmental specifications.....	467
Table 539	AZNC functional specification.....	468
Table 540	AZNC interfaces.....	469
Table 541	AZNC ALD support.....	470
Table 542	AZNC electrical specifications.....	471
Table 543	AZNC power consumption in LTE mode.....	472
Table 544	Recommended AZNC power reduction in 256 QAM.....	472
Table 545	AZNC dimensions and weight.....	473
Table 546	AZNC environmental specifications.....	473
Table 547	AZQP functional specification.....	474
Table 548	AZQP interfaces.....	475
Table 549	AZQP ALD support.....	476
Table 550	AZQP electrical specifications.....	477
Table 551	AZQP dimensions and weight.....	479
Table 552	AZQP environmental specifications.....	479
Table 553	AZQE functional specification.....	480

Table 554	AZQE interfaces.....	481
Table 555	AZQE ALD support.....	482
Table 556	AZQE electrical specifications.....	483
Table 557	AZQE power consumption in LTE mode.....	484
Table 558	Recommended AZQE power reduction in 256 QAM.....	484
Table 559	AZQE dimensions and weight.....	485
Table 560	AZQE environmental specifications.....	485
Table 561	AZQF functional specification.....	486
Table 562	AZQF interfaces.....	488
Table 563	AZQF ALD support.....	489
Table 564	AZQF electrical specifications.....	490
Table 565	AZQF power consumption in LTE mode.....	490
Table 566	Recommended AZQF power reduction in 256 QAM.....	491
Table 567	AZQF dimensions and weight.....	492
Table 568	AZQF environmental specifications.....	492
Table 569	Nokia AirScale RRH sound power levels (measured according to ISO 3744).....	493
Table 570	Nokia AirScale 2 300 RRH sound power levels (measured according to ISO 3744).....	493
Table 571	Nokia AirScale 2 600 RRH sound power levels (measured according to ISO 3744).....	493
Table 572	LEDs for RF Modules.....	494
Table 573	LEDs for RRHs.....	495
Table 574	Typical reference sensitivity degradation with different Antenna line PIM performance.	497

Summary of changes

A list of changes between document issues. You can navigate through the respective changed topics.

In this summary of changes:

- [Changes between issues 25 \(2020-05-28\) and 27 \(2020-07-30\)](#)
- [Changes between issues 24 \(2020-04-08\) and 25 \(2020-05-28\)](#)
- [Changes between issues 23 \(2020-02-17\) and 24 \(2020-04-08\)](#)

Changes between document issues are cumulative. Therefore, the latest document issue contains all changes made to previous issues.



Note: For more details on Nokia AirScale compliance, see [Nokia AirScale BTS Environmental Product Declaration](#).

Changes between issues 25 (2020-05-28) and 27 (2020-07-30)

General changes

- 5G support has been added to:
 - [Nokia AirScale RRH 2T4R B1/n1 120 W \(AHGA\)](#)
 - [Nokia AirScale RRH 4T4R B1/n1 320 W \(AHGD\)](#)
 - [Nokia AirScale RRH 4T4R B7/n7 160 W \(AHHB\)](#)
 - [Nokia AirScale RRH 4T4R B66/n66 160 W \(FRIJ\)](#)
 - [Nokia AirScale RRH 4T4R B40/n40 160 W \(AZNA\)](#)
 - [Nokia AirScale RRH 4T4R B41/n41 160 W \(AZHA\)](#)
- FMWM and FMWV optional items support has been added to:
 - [Nokia AirScale Micro RRH 2T B46 UNII 1+2+3 1 W \(AZRB\)](#)
 - [Nokia AirScale Micro RRH 2T B46 UNII 1+2+3 1 W \(AZRC\)](#)
 - [Nokia AirScale Micro 4T4R B25 20 W \(AHFB\)](#)
 - [Nokia AirScale Micro 4T4R B66 20 W \(AHIB\)](#)
- FMWM optional item support has been added to:
 - [Nokia AirScale Micro 4T4R B1 20 W \(AHGB\)](#)
 - [Nokia AirScale Micro 4T4R B3 20 W \(AHEJ\)](#)
 - [Nokia AirScale Micro 4T4R B7 20 W \(AHHA\)](#)

[Nokia AirScale RRH 4T4R B26 200 W \(AHCF\)](#)

- [Table 236: AHCF dimensions and weight](#) has been updated.

[Nokia AirScale Dual RRH 4T4R B1/3 \(n1/n3\) 400 W \(AHEGC\)](#)

- ASFC has been removed from the optional items list.

[Nokia AirScale Micro RRH 4T4R B41/n41 80 W \(AWHHD\)](#)

- The bookshelf installation option has been removed.

Nokia AirScale Micro RRH 4T4R B41/n41 80 W (AWHHF)

- The bookshelf installation option has been removed.
- FMWV has been added to the list of the optional items.

Nokia AirScale Micro 4T4R CBRS 20 W (AZQC)

- FMWV has been added to the list of the optional items.

Changes between issues 24 (2020-04-08) and 25 (2020-05-28)

General changes

- Nokia AirScale RRH 4T4R B1/n1 320 W (AHGD) has been added.
- 5G support and related information (for example: feature number, number of supported carriers per pipe) has been added/updated:
 - Nokia AirScale RFM 6T6R B1/n1 480 W (ARGA)
 - Nokia AirScale RFM 6T6R B3/n3 480 W (AREA)
 - Nokia AirScale RFM 6T6R B28/n28 360 W (ARPA)
 - Nokia AirScale RRH 2T4R B8/n8 160 W (AHDB)
 - Nokia AirScale RRH 2T4R B28/n28 120 W (AHPD)
 - Nokia AirScale RRH 4T4R B3/n3 160 W (AHEB)
 - Nokia AirScale RRH 4T4R B28/n28 320 W (AHPB)
 - Nokia AirScale Dual RRH 2T4R B1/3 (n1/n3) 240 W (AHEGA)
 - Nokia AirScale Dual RRH 4T4R B1/3 (n1/n3) 320 W (AHEGB)
 - Nokia AirScale Dual RRH 4T4R B1/3 (n1/n3) 400 W (AHEGC)
 - Nokia AirScale Dual RRH 4T4R B2/66a (n2/n66a) 320 W (AHFIC)
 - Nokia AirScale Dual RRH 4T4R B5/13 (n5) 160 W (AHBCA)
 - Nokia AirScale Dual RRH 4T4R B5/28 (n5/n28) 320 W (AHPCA)
 - Nokia AirScale Dual RRH 4T4R B8/28 (n8/n28) 480 W (AHPDA)
 - Nokia AirScale Dual RRH 4T4R B13/71 (n71) 240 W (AHBOA)
 - Nokia AirScale Dual RRH 4T4R B25/66 (n25/n66) 480 W (AHFIG)
 - Nokia AirScale Dual RRH 4T4R B25/B66a (n25/n66a) 160 W (AHFIA)
 - Nokia AirScale Tri RRH 2T4R B8/20/28 (n8/n20/n28) 240 W (AHPMDB)
 - Nokia AirScale Tri RRH 2T4R B5/8/28 (n5/n8/n28) 240 W (AHPCDB)
 - Nokia AirScale Micro RRH 4T4R B41/n41 80 W (AWHHD)
 - Nokia AirScale Micro RRH 4T4R B41/n41 80 W (AWHHF)
- One-clip rail installation option has been added to AirScale 2 units which support AMRA/B and ARMC.
- Antenna Line Devices (ALDs) support has been updated in:
 - Nokia AirScale RRH 2T4R B1/n1 120 W (AHGA)
 - Nokia AirScale RRH 2T4R B1 120 W (AHGC)
 - Nokia AirScale RRH 2T4R B8 120 W (AHDA)
 - Nokia AirScale RRH 2T4R B20 120 W (AHMA)
 - Nokia AirScale RRH 2T4R B28 120 W (AHPE)

- [Nokia AirScale RRH 4T4R B26a 100 W \(AHCC\)](#)
- Support for APAF optional item has been added to:
 - [Nokia AirScale Dual RRH 2T4R B1/3 \(n1/n3\) 240 W \(AHEGA\)](#)
 - [Nokia AirScale Dual RRH 2T2R B29/70 200 W \(AHLJA\)](#)
 - [Nokia AirScale Dual RRH 4T4R B5/13 \(n5\) 160 W \(AHBCA\)](#)
 - [Nokia AirScale Dual RRH 4T4R B12/71 240 W \(AHLOA\)](#)
 - [Nokia AirScale Dual RRH 4T4R B13/71 \(n71\) 240 W \(AHBOA\)](#)
 - [Nokia AirScale Dual RRH 4T4R B25/B66a \(n25/n66a\) 160 W \(AHFIA\)](#)
 - [Nokia AirScale Tri RRH 2T2R B8/20/28 240 W \(AHPMDA\)](#)
 - [Nokia AirScale Tri RRH 2T4R B5/8/28 \(n5/n8/n28\) 240 W \(AHPCDB\)](#)
 - [Nokia AirScale Tri RRH 2T4R B8/20/28 \(n8/n20/n28\) 240 W \(AHPMDB\)](#)

List of Radio Units

- Note about radios supporting 5G has been added.

[Nokia AirScale RFM 6T6R B8 480 W \(ARDA\)](#)

- [Power consumption](#) has been added.

[Nokia AirScale RRH 2T4R B3 160 W \(AHEC\)](#)

- GSM and GSM-LTE support added.

[Nokia AirScale RRH 8T8R B42 160 W \(AZQP\)](#)

- Fan location has been updated in AZQP interfaces [table](#).
- AMRB and AMRC have been added to [Related optional items](#).
- One-clip rail installation option has been added.

Changes between issues 23 (2020-02-17) and 24 (2020-04-08)

General changes

- Sections *Warnings, cautions or notes related to the product* have been removed. The respective notes have been moved to appropriate sections in each unit description.
- 5G readiness has been added to:
 - [Nokia AirScale Macro FDD-LTE Radios](#)
 - [Descriptions of Micro RRHs](#)
- 5G support has been added to:
 - [Nokia AirScale RRH 4T4R B28/n28 320 W \(AHPB\)](#)
 - [Nokia AirScale Dual RRH 4T4R B1/3 \(n1/n3\) 320 W \(AHEGB\)](#)
 - [Nokia AirScale Micro 4T4R B66 20 W \(AHIB\)](#)
 - [Nokia AirScale Micro 4T4R B1 20 W \(AHGB\)](#)
 - [Nokia AirScale Micro 4T4R B3 20 W \(AHEJ\)](#)
 - [Nokia AirScale Micro 4T4R B5 20 W \(AHCE\)](#)
 - [Nokia AirScale Micro 4T4R B7 20 W \(AHHA\)](#)

- Nokia AirScale Micro 4T4R B25 20 W (AHFB)
- Power reduction for 256QAM has been added:
 - Table 521: Recommended AZNA power reduction in 256 QAM
 - Table 536: Recommended AZNB power reduction in 256 QAM
 - Table 558: Recommended AZQE power reduction in 256 QAM
 - Table 566: Recommended AZQF power reduction in 256 QAM
- Maximum operational temperatures have been updated:
 - Nokia AirScale Micro RRH 4T4R B41/n41 80 W (AWHHD)
 - Nokia AirScale Micro RRH 4T4R B41/n41 80 W (AWHHF)

Nokia AirScale RRH 2T4R B3 160 W (AHEC)

- GSM and GSM-LTE support added.

Nokia AirScale RRH 4T4R B26 200 W (AHCF)

- AHCF output power has been changed to 2 x 40 W + 2 x 60 W.
- Table 236: AHCF dimensions and weight has been updated.

Nokia AirScale Dual RRH 4T4R B1/3 (n1/n3) 400 W (AHEGC)

- Power consumption has been added.

Nokia AirScale Tri RRH 4T4R B12/14/29 370 W (AHLBBA)

- TX/RX range, filter BW, iBW, and oBW have been updated:
 - Band 12 (incl.band 17): UL (RX) 699 MHz – 715 MHz, DL (TX) 729 MHz – 745 MHz
 - Band 29: DL (TX) 717MHz - 728 MHz

1 Nokia AirScale Radio compliances

RSS-102, EU, FCC, EMC, RF, and safety compliances

1.1 RSS-102 compliance

Following are example minimum separation distances calculated to meet the limits of RSS-102, Issue 5 for deployment of Nokia base station products. These calculated distances assume a typical 16.4 dBi gain antenna. For other antenna gains the compliance boundaries should be recalculated.

Ci-dessous sont par exemple les distances minimales de séparation calculées pour respecter les limites de RSS-102, numéro 5 pour le déploiement de la station de base Nokia. Ces distances calculées supposent une antenne de gain typique 16,4 dBi. Pour d'autres gains d'antenne les limites de conformité doivent être recalculées.

Table 1 RSS-102 Issue 5 Compliance boundaries (m) for general public levels

Power (W)	Frequency range (MHz)			
	698 - 960		1710 - 2690	
	Limit (W/m ²)	Distance (m)	Limit (W/m ²)	Distance (m)
2	2.30	1.8	4.24	1.3
5	2.30	2.8	4.24	2.1
10	2.30	3.9	4.24	2.9
20	2.30	5.5	4.24	4.1
30	2.30	6.8	4.24	5.0
40	2.30	7.8	4.24	5.8
50	2.30	8.7	4.24	6.4
60	2.30	9.6	4.24	7.1
70	2.30	10.3	4.24	7.6
80	2.30	11.0	4.24	8.1
90	2.30	11.7	4.24	8.6

Table 2 RSS-102 Issue 5 Compliance boundaries (m) for occupational levels

Power (W)	Frequency range (MHz)			
	698 - 960		1710 - 2690	
	Limit (W/m ²)	Distance (m)	Limit (W/m ²)	Distance (m)
2	17.05	0.7	26.69	0.6
5	17.05	1.1	26.69	0.9
10	17.05	1.5	26.69	1.2
20	17.05	2.1	26.69	1.7
30	17.05	2.5	26.69	2.0

Table 2 RSS-102 Issue 5 Compliance boundaries (m) for occupational levels (Cont.)

Power (W)	Frequency range (MHz)			
	698 - 960		1710 - 2690	
	Limit (W/m ²)	Distance (m)	Limit (W/m ²)	Distance (m)
40	17.05	2.9	26.69	2.3
50	17.05	3.2	26.69	2.6
60	17.05	3.5	26.69	2.8
70	17.05	3.8	26.69	3.1
80	17.05	4.1	26.69	3.3
90	17.05	4.3	26.69	3.5

1.2 EU compliance

EU RoHS statement, CE marking, Directive 2014/53/EU (RED) Article 10.10 compliance

EU RoHS statement

This equipment complies with the European Union RoHS Directive 2011/65/EU on the restriction of the use of certain hazardous substances in electrical and electronic equipment. The directive applies to the use of lead, mercury, cadmium, hexavalent chromium, Polybrominated Biphenyls (PBB), and Polybrominated Diphenyl Ethers (PBDE) in electrical and electronic equipment.

CE marking

The equipment described in this document faithfully complies with either:

- The relevant provisions of the European Union R&TTE Directive 1999/5/EC for some products shipped prior to June 30, 2017

Figure 1 CE marking (EU R&TTE Directive 1999/5/EC)



Hereby, Nokia declares that one or more of these Base Stations is in compliance with the essential requirements and other relevant provisions of Directive: 1999/5/EC.

or

- European Union Radio Equipment Directive (RED) 2014/53/EU for some current products and all products shipped after June 30, 2017.

Figure 2 CE marking



Hereby, Nokia declares that radio equipment type Flexi Multiradio BTS, Flexi Multiradio 10 BTS and Nokia AirScale BTS is in compliance with Directive 2014/53/EC. The full text of the EU declaration of conformity is available at the following internet address: <https://online.networks.nokia.com>

These declarations are only valid for configurations (combinations of software, firmware, and hardware) provided and/or supported by Nokia.

Directive 2014/53/EU (RED) Article 10.10 compliance

The radio frequency usage in EU is restricted and before taking the radio equipment in use in the commercial network the operator is to apply for the band license from the local regulator.

As an evidence for the restriction, the packaging is to have the RED Article 10.10-marking describing the impacted countries.

Figure 3 RED Article 10.10-marking



Restrictions in			
AT	BE	BG	HR
CY	CZ	DK	EE
FI	FR	DE	EL
HU	IE	IT	LV
LT	LU	MT	NL
PL	PT	RO	SK
SI	ES	SE	UK

1.3 FCC Part 15 compliance



Note: This equipment has been tested and found to comply with the limits for a Class B digital device, pursuant to Part 15 of the FCC Rules. These limits are designed to provide reasonable protection against harmful interference in a residential installation. This equipment generates, uses, and can radiate radio frequency energy and, if not installed and used in accordance with the instruction, may cause harmful interference to radio communications. However, there is no guarantee that interference will not occur in a particular installation. If this equipment does cause harmful interference to radio or television reception, which can be determined by turning the equipment off and on, the user is encouraged to try to correct the interference by one or more of the following measures:

- Reorient or relocate the receiving antenna.
- Increase the separation between the equipment and receiver.
- Connect the equipment into an outlet on a circuit different from that to which the receiver is connected.
- Consult the dealer or an experienced radio/TV technician for help.

Changes or modifications not expressly approved by the party responsible for compliance could void the user's authority to operate the equipment.

1.4 Compliance with EMC, RF and safety

EMC emission, EMC immunity, RF, and safety standards for Flexi and AirScale BTS.

In Europe, this means compliance with Directive 2014/53/EU of the European Parliament and of the Council of 16 April 2014 on the harmonisation of the laws of the Member States relating to the making available on the market of radio equipment and repealing Directive 1999/5/EC Text with EEA relevance.

In other market areas additional compliance is fulfilled according to relevant authority requirements.

EMC emission

- Common:
 - ETSI EN 301 489-1: ElectroMagnetic Compatibility (EMC) standard for radio equipment and services; Part 1: Common technical requirements; Harmonised Standard covering the essential requirements of article 3.1(b) of Directive 2014/53/EU and the essential requirements of article 6 of Directive 2014/30/EU
 - ETSI EN 301 489-50: ElectroMagnetic Compatibility (EMC) standard for radio equipment and services; Part 50: Specific conditions for Cellular Communication Base Station (BS), repeater and ancillary equipment; Harmonised Standard covering the essential requirements of article 3.1(b) of Directive 2014/53/EU
 - EN 55032: Electromagnetic compatibility of multimedia equipment - Emission Requirements
 - ICES-003: Information Technology Equipment (ITE) – Limits and Methods of Measurement
 - FCC Code of Federal Regulations (CFR) 47, Part 15 Radio Frequency Devices

- MSR:
 - 3GPP TS 37.113: 3rd Generation Partnership Project; Technical Specification Group Radio Access Network; E-UTRA, UTRA and GSM/EDGE; Multi-Standard Radio (MSR) Base Station (BS) Electromagnetic Compatibility (EMC)
- GSM/EDGE:
 - 3GPP TS 51.021: 3rd Generation Partnership Project; Technical Specification Group Radio Access Network; Base Station System (BSS) equipment specification; Radio aspects - Section 8 Radiated Spurious Emissions
- UTRA:
 - 3GPP TS 25.113: 3rd Generation Partnership Project; Technical Specification Group Radio Access Network; Base Station (BS) and repeater ElectroMagnetic Compatibility (EMC)
- E-UTRA:
 - 3GPP TS 36.113: 3rd Generation Partnership Project; Technical Specification Group Radio Access Network; Evolved Universal Terrestrial Radio Access (E-UTRA); Base Station (BS) and repeater ElectroMagnetic Compatibility (EMC)
- 5G:
 - 3GPP TS 38.113: 3rd Generation Partnership Project; Technical Specification Group Radio Access Network; NR; Base Station (BS) ElectroMagnetic Compatibility (EMC)

EMC immunity

- Common:
 - ETSI EN 301 489-1: ElectroMagnetic Compatibility (EMC) standard for radio equipment and services; Part 1: Common technical requirements; Harmonised Standard covering the essential requirements of article 3.1(b) of Directive 2014/53/EU and the essential requirements of article 6 of Directive 2014/30/EU
 - ETSI EN 301 489-50: ElectroMagnetic Compatibility (EMC) standard for radio equipment and services; Part 50: Specific conditions for Cellular Communication Base Station (BS), repeater and ancillary equipment; Harmonised Standard covering the essential requirements of article 3.1(b) of Directive 2014/53/EU
 - IEC 61000-4-8/EN 61000-4-8: Electromagnetic compatibility (EMC) – Part 4-8: Testing and measurement techniques – Power frequency magnetic field immunity test
 - IEC 61000-4-9 / EN 61000-4-9: Electromagnetic compatibility (EMC). Part 4-9: Testing and measurement techniques. Pulse magnetic field immunity test
- MSR:
 - 3GPP TS 37.113: 3rd Generation Partnership Project; Technical Specification Group Radio Access Network; E-UTRA, UTRA and GSM/EDGE; Multi-Standard Radio (MSR) Base Station (BS) Electromagnetic Compatibility (EMC)
- UTRA:
 - 3GPP TS 25.113: 3rd Generation Partnership Project; Technical Specification Group Radio Access Network; Base Station (BS) and repeater ElectroMagnetic Compatibility (EMC)
- E-UTRA:

- 3GPP TS 36.113: 3rd Generation Partnership Project; Technical Specification Group Radio Access Network; Evolved Universal Terrestrial Radio Access (E-UTRA); Base Station (BS) and repeater ElectroMagnetic Compatibility (EMC)
- 5G:
 - 3GPP TS 38.113: 3rd Generation Partnership Project; Technical Specification Group Radio Access Network; NR; Base Station (BS) ElectroMagnetic Compatibility (EMC)

RF

- Common:
 - ETSI EN 301 908-1: IMT cellular networks; Harmonized EN covering the essential requirements of article 3.2 of the R&TTE Directive; Part 1: Introduction and common requirements
 - FCC Code of Federal Regulations (CFR) 47, Part 2: Frequency Allocations and Radio Treaty Matters; General Rules and Regulations
 - FCC Code of Federal Regulations (CFR) 47, Part 22: Public mobile Services (2110-2130MHz and 2160-2180MHz)
 - FCC Code of Federal Regulations (CFR) 47, Part 24: Personal Communication Services
 - FCC Code of Federal Regulations (CFR) 47, Part 25: Satellite Communications
 - FCC Code of Federal Regulations (CFR) 47, Part 27: Miscellaneous Wireless Communications Services (758-763MHz and 788-793MHz) (1710-1755MHz and 2110-2155MHz)
 - FCC Code of Federal Regulations (CFR), Part 30: Upper microwave flexible use service
 - FCC Code of Federal Regulations (CFR) 47, Part 90: Private Land Mobile Radio Services
 - RSS-Gen: General Requirements and Information for the Certification of Radio Apparatus
 - RSS-130: Mobile Broadband Services (MBS) Equipment Operating in the Frequency Bands 698-756 MHz and 777-787 MHz
 - RSS-132: Cellular Telephones Employing New Technologies Operating in the Bands 824-849 MHz and 869-894 MHz
 - RSS-133: 2GHz Personal Communications Services
 - RSS-139: Advanced Wireless Services Equipment Operating in the Bands 1710-1755 MHz and 2110-2155 MHz
 - RSS-140: Equipment operating in the Public Safety Broadband Frequency Bands 758-768MHz and 788-798MHz
 - RSS-170: Mobile Earth Stations (MESs) and Ancillary Terrestrial Component (ATC) Equipment Operating in the Mobile-Satellite Service (MSS) Bands
 - RSS-195: Wireless Communication Service (WCS) Equipment Operating in the Bands 2305-2320 MHz and 2345-2360 MHz
 - RSS-199: Broadband Radio Service (BRS) Equipment Operating in the Band 2500-2690
- AAS:
 - 37.145-1: 3rd Generation Partnership Project; Technical Specification Group Radio Access Network: Active Antenna System (AAS) Base Station (BS) Conformance testing; Part 1: Conducted conformance testing

-
- 37.145-2: 3rd Generation Partnership Project; Technical Specification Group Radio Access Network: Active Antenna System (AAS) Base Station (BS) Conformance testing; Part 2: Radiated Conformance testing
 - MSR:
 - ETSI EN 301 908-18: IMT cellular networks; Harmonized EN covering the essential requirements of article 3.2 of the R&TTE Directive; Part 18: E-UTRA, UTRA and GSM/EDGE Multi-Standard Radio (MSR) Base Station (BS)
 - 3GPP TS 37.141: 3rd Generation Partnership Project; Technical Specification Group Radio Access Network; E-UTRA, UTRA and GSM/EDGE; Multi-Standard Radio (MSR) Base Station (BS) conformance testing
 - GSM/EDGE:
 - ETSI EN 301 502: Global System for Mobile communications (GSM); Harmonized EN for Base Station Equipment covering the essential requirements of article 3.2 of the R&TTE Directive
 - 3GPP TS 51.021: 3rd Generation Partnership Project; Technical Specification Group GSM/EDGE Radio Access Network; Base Station System (BSS) equipment specification; Radio aspects
 - UTRA:
 - ETSI EN 301 908-3: IMT cellular networks; Harmonized EN covering the essential requirements of article 3.2 of the R&TTE Directive; Part 3: CDMA Direct Spread (UTRA FDD) Base Stations (BS)
 - 3GPP TS 25.141: 3rd Generation Partnership Project; Technical Specification Group Radio Access Network; Base Station (BS) conformance testing (FDD)
 - Telec-T112
 - E-UTRA:
 - ETSI EN 301 908-14: IMT cellular networks; Harmonized EN covering the essential requirements of article 3.2 of the R&TTE Directive; Part 14: Evolved Universal Terrestrial Radio Access (E-UTRA) Base Stations (BS)
 - 3GPP TS 36.141: 3rd Generation Partnership Project; Technical Specification Group Radio Access Network; Evolved Universal Terrestrial Radio Access (E-UTRA); Base Station (BS) conformance testing
 - Telec-T139
 - Telec-T146
 - Telec-T156
 - 5G:
 - 3GPP TS 38.141-1: 3rd Generation Partnership Project; Technical Specification Group RAN; NR; Base Station (BS) conformance testing Part 1: Conducted conformance testing
 - 3GPP TS 38.141-2: 3rd Generation Partnership Project; Technical Specification Group RAN; NR; Base Station (BS) conformance testing Part 2: Radiated conformance testing

Safety

- EN 50385: Product standard to demonstrate the compliances of base station equipment with radio frequency electromagnetic field exposure limits (110 MHz - 100 GHz), when placed on the market
- FCC 47 CFR Part 1.1310

-
- ISED Canada: Health Canada Safety Code 6
 - Australia: ARPANSA Radiation Protection Series No.3
 - EN 62232: Determination of RF field strength, power density and SAR in the vicinity of radio communication base stations for the purpose of evaluating human exposure
 - either
 - IEC 60950-1/EN 60950-1/UL 60950-1/CSA C22.2 No. 60950-1: Information technology equipment – Safety – Part 1: General requirements
 - or
 - IEC 62368-1/EN 62368-1/UL 62368-1/CSA C22.2 No. 62368-1-14: Audio/video, information and communication technology equipment – Part 1: Safety requirements
 - IEC 60950-22/EN 60950-22/UL 60950-22/ CSA C22.2 No. 60950-22: Information technology equipment – Safety – Part 22: Equipment to be installed outdoor

2 RF performance

The topic describes RF sensitivity, TX output power tolerance, Received interference power, RF bandwidth terms.

RF sensitivity

Nokia AirScale macro radios have superior field-proven RX sensitivity which ensures a top uplink performance without compromising the uplink coverage.

The uplink performance accuracy tests were made in compliance with 3GPP standard 36.104. The receiver sensitivity have been measured using commercial radio hardware under realistic circumstances. The top results reached -106.6 dBm and the accurate mean is -106.3 dBm.

TX output power tolerance

Nokia AirScale radios power amplifier design brings benefits to the radio units with wide operating bandwidth and wide instantaneous bandwidth. This design produces a competitive output power tolerance which is less than +/-0.8 dB for single band radio units. Its benefit is a high maximum downlink throughput level in real operating environments.

Received interference power

Nokia AirScale macro radios' reporting accuracy complies with 3GPP standard 36.133. The reported level of Received Interference Power may slightly vary between units and different product variants. It has no impact on radio performance aspects, such as sensitivity or data throughput.

RF bandwidth terms

The descriptions of radio units contain certain BW-related information. The definitions are as follows:

RF filter bandwidth (RF BW)	The 3GPP frequency range the radio operates in. Example: Filter bandwidth of a radio unit operating in Band 41 (2496 MHz to 2690 MHz) is 194 MHz.
Instantaneous bandwidth (iBW)	A frequency range in which the radio carriers may be deployed in. Is always smaller or equal to RF BW.
Occupied bandwidth (oBW)	The HW-supported maximum sum of the deployed carriers' bandwidth. Is always smaller or equal to iBW. Example: If a radio unit oBW = 40 MHz, there might be a 2 x 20 MHz configuration deployed.

3 Nokia AirScale Radio support for BTS

Supported Nokia System Modules. Related documents.

Nokia AirScale radio units listed in this document are all supported by Nokia AirScale System Module. The units are also supported by either or both:

- Flexi Multiradio 10 Base Station System Module Outdoor (FSMF)
- Flexi Multiradio 10 Base Station System Module Indoor (FSIH)

To check which radio unit is compatible with the respective System Module, see one of the documents:

- *LTE List of Features (XLS)*
- *LTE/EPC RAN Compatibility / Compatibility between hardware items*
- *Single RAN Compatibility / Compatibility between hardware items*

For information on Flexi radio units refer to *Flexi Multiradio BTS RF Module and Remote Radio Head Description*.

For information on supported configurations, see one of the documents:

- *Creating Nokia AirScale BTS TD-LTE Configurations*
- *Creating Nokia AirScale BTS FDD-LTE Configurations*
- *Creating Flexi Multiradio 10 BTS FDD-LTE Configurations*
- *Creating Flexi Multiradio 10 BTS TD-LTE Configurations*
- *SBTS Supported Configurations (XLS)*, in Single RAN Operating Documentation in the Support Portal

4 List of Radio Units

List of LTE and SRAN releases in which the Radio Modules were introduced; product codes and feature numbers.



Note: Some radio units are introduced to SRAN in LTE-only mode. They are marked with the relevant feature number:

- SRAN 18 - SR001695: Support of additional dedicated LTE18 radios in SRAN
- SRAN 18 SP - SR002039: Support of dedicated LTE radios in SRAN 18 SP
- SRAN 18A - SR001791: Support of additional dedicated LTE 18A radios in SRAN
- SRAN 19 - SR002260: Support of dedicated LTE radios in SRAN 19



Note: Some radio units support 5G in various releases, see the respective 5G roadmap.

Table 3 RF Modules

RF Module name	Feature number	Product code	Introduced in LTE release	Introduced in SRAN release
Nokia AirScale RFM 6T6R B1 480 W (ARGA)	LTE4640 SR002273	474800A	LTE 19	SRAN 19
Nokia AirScale RFM 6T6R B3 480 W (AREA)	LTE4208 SR001943	474198A	LTE 18A	SRAN 18A
Nokia AirScale RFM 6T6R B5 480 W (ARCA)	LTE4662 SR002152	474841A	LTE 19	SRAN 19
Nokia AirScale RFM 6T6R B7 360 W (ARHA)	LTE4641	474801A	LTE 19A	-
Nokia AirScale RFM 6T6R B8 480 W (ARDA)	SR002611	474840A	SRAN 20A	
Nokia AirScale RFM 6T6R B8 480 W (ARDB)	SR002531	475122A	-	SRAN 19B
Nokia AirScale RFM 6T6R B20 360 W (ARMA)	LTE5070	474803A	LTE 19A	-
Nokia AirScale RFM 6T6R B28 360 W (ARPA)	LTE4663	474802A	LTE 19A	-

Table 4 Single band Remote Radio Heads

RRH name	Feature number	Product code	Introduced in LTE release	Introduced in SRAN release
Nokia AirScale RRH 2T B32/75 120 W (AHSA)	LTE5048	475015A	LTE 19A	-
Nokia AirScale RRH 2T2R B3 120 W (FHEL)	LTE2680 SR001121	473475A	LTE16A	SRAN 16.10
Nokia AirScale RRH 2T2R 900J 120 W (FHDI)	LTE3516 SR001451	473825A	LTE 18	SRAN 17A
Nokia AirScale RRH 2T2R B11 120 W (FHKA)	LTE3184 SR001791	473838A	LTE16A	SRAN 18A
Nokia AirScale RRH 2T2R B28 120 W (FHPD)	LTE3181	473821A	LTE 17A	-
Nokia AirScale RRH 2T2R 700 120 W (FHPG)	LTE4167 SR002260	474407A	LTE 18	SRAN 19
Nokia AirScale RRH 2T4R B1 120 W (AHGA)	LTE3764 SR001768	474254A	LTE 18A	SRAN 19
Nokia AirScale RRH 2T4R B1 120 W (AHGC)	LTE4510 SR001791	474586A	LTE 18A	SRAN 18A
Nokia AirScale RRH 2T4R B3 160 W (AHEC)	LTE3087 SR001389	473806A	LTE 18A	SRAN 18SP
Nokia AirScale RRH 2T4R B3 160 W (AHED)	LTE3130 SR001415	473807A	LTE 18	SRAN 18SP
Nokia AirScale RRH 2T4R B8 120 W (AHDA)	LTE3678 SR001667	474060A	LTE 18A	SRAN 18A
Nokia AirScale RRH 2T4R B8 160 W (AHDB)	LTE3837 SR001753	474257A	LTE 18	SRAN 18SP
Nokia AirScale RRH 2T4R B20 120 W (AHMA)	LTE4118 SR002039	474255A	LTE 18SP	SRAN 18SP
Nokia AirScale RRH 2T4R B28 120 W (AHPC)	LTE4615 SR001791	474649A	LTE 18A	SRAN 18A
Nokia AirScale RRH 2T4R B28 120 W (AHPD)	LTE4660 SR002080	474712A	LTE 19	SRAN 19

Table 4 Single band Remote Radio Heads (Cont.)

RRH name	Feature number	Product code	Introduced in LTE release	Introduced in SRAN release
Nokia AirScale RRH 2T4R B28 120 W (AHPE)	LTE5359	475208A	LTE 19B	SRAN 19B
Nokia AirScale RRH 4T4R B1/n1 320 W (AHGD)	SR002924	475579A	SRAN 20B	
Nokia AirScale RRH 4T4R B3 160 W (AHEB)	LTE2784 SR001206	473484A	LTE 18	SRAN 18SP
Nokia AirScale RRH 4T4R B3 160W (AHEH)	LTE4686 SR002165	474253A	LTE 18A	SRAN 18A
Nokia AirScale RRH 4T4R B7 160 W (AHHB)	LTE3137 SR002039	474252A	LTE 18	SRAN 18SP
Nokia AirScale RRH 4T4R B5 160 W (AHCA)	LTE3399 SR002145	473966A 473966B	LTE 17A	SRAN 18A
Nokia AirScale RRH 4T4R B26 200 W (AHCF)	SR002703	475313A	SRAN 20A	
Nokia AirScale RRH 4T4R B26a 100 W (AHCC)	LTE4260 SR002260	474469A	LTE 19	SRAN 19
Nokia AirScale RRH 4T4R B28 320 W (AHPB)	LTE3651 SR002039	474119A	LTE 17ASP1	SRAN 18SP
Nokia AirScale RRH 4T4R B30 100 W (AHNA)	LTE4637 SR002260	474861A	LTE 18A	SRAN 19
Nokia AirScale RRH 4T4R B66 160 W (FRIJ)	LTE2516 SR001361	473368A	LTE 16A	SRAN 18SP

Table 5 Dual band Remote Radio Heads

RRH name	Feature number	Product code	Introduced in LTE release	Introduced in SRAN release
Nokia AirScale Dual RRH 2T4R B1/3 240 W (AHEGA)	LTE3140 SR001575	473995A	LTE 18	SRAN 18SP
Nokia AirScale RRH Dual 2T2R B29/70 200 W (AHLJA)	LTE4228 SR001791	474663A	LTE 18A	SRAN 18A

Table 5 Dual band Remote Radio Heads (Cont.)

RRH name	Feature number	Product code	Introduced in LTE release	Introduced in SRAN release
Nokia AirScale Dual RRH 4T4R B1/3 320 W (AHEGB)	LTE3681 SR001668	474090A	LTE 18	SRAN 18SP
Nokia AirScale Dual RRH 4T4R B1/3 400 W (AHEGC)	LTE4970 SR002211	474914A	LTE 19A	SRAN 19A
Nokia AirScale Dual RRH 4T4R B2/66a 320 W (AHFIC)	LTE3845 SR002369	474239A	LTE 18	SRAN 18SP
Nokia AirScale Dual RRH 4T4R B5/13 160 W (AHBCA)	LTE3848 SR002039	474241A	LTE 18SP	SRAN 18SP
Nokia AirScale Dual RRH 4T4R B5/13 320 W (AHBCC)	LTE3849 SR002039	474341A	LTE 18	SRAN 18SP
Nokia AirScale Dual RRH 4T4R B5/28 320W (AHPCA)	SR002545	475075A	-	SRAN 19B
Nokia AirScale Dual RRH 4T4R B5/29 240 W (AHBCB)	LTE3846	474242A	LTE 19A Fast Delivery Mode in LTE 19	-
Nokia AirScale Dual RRH 4T4R B8/B28 480 W (AHPDA)	SR002869	475550A	SRAN 20A	
Nokia AirScale Dual RRH 4T4R B12/14 320 W (AHLBA)	LTE3847 SR002039	474240A	LTE 18	SRAN 18SP
Nokia AirScale Dual RRH 4T4R B12/71 240 W(AHLOA)	LTE3899 SR002039	474331A	LTE 18	SRAN 18SP
Nokia AirScale Dual RRH 4T4R B13/71 240 W(AHBOA)	LTE4988	475250A	LTE 19B	SRAN 19B
Nokia AirScale Dual RRH 4T4R B25/66 320 W (AHFIB)	LTE3789 SR001767	474216A	LTE 17ASP1	SRAN 18SP
Nokia AirScale Dual RRH 4T4R B25/66 480 W (AHFIG)	LTE5213 SR002418	475125A	LTE 19A	SRAN 19A
Nokia AirScale Dual RRH 4T4R B25/B66a 160 W (AHFIA)	LTE3421 SR002039	473967A	LTE 18	SRAN 18SP

Table 6 Triple band Remote Radio Heads

RRH name	Feature number	Product code	Introduced in LTE release	Introduced in SRAN release
Nokia AirScale Tri RRH 2T2R B8/20/28 240 W (AHPMDA)	LTE3142 SR001572	473997A	LTE 18	SRAN 18SP
Nokia AirScale Tri RRH 2T4R B5/8/28 240W (AHPADB)	SR002520	475081A	SRAN 20A	
Nokia AirScale Tri RRH 2T4R B8/20/28 240W (AHPMDB)	SR002368	475000A	-	SRAN 19B
Nokia AirScale Tri RRH 4T4R B12/14/29 370 W (AHLBBA)	LTE5210	475082A	LTE 19B	SRAN 19B

Table 7 Micro Remote Radio Heads

RRH name	Feature number	Product code	Introduced in LTE release	Introduced in SRAN release
Nokia AirScale Micro RRH 2T B46 UNII 1+3 1 W (AZRA)	LTE3712 SR001791	474146A	LTE 18	SRAN 18A
Nokia AirScale Micro RRH 2T B46 UNII 1+2+3 1W (AZRB)	LTE4253 SR001791	474510A	LTE 18	SRAN 18A
Nokia AirScale Micro RRH 2T B46 UNII 1+2+3 1W (AZRC)	LTE4872	474784A	SRAN 20A	
Nokia AirScale Micro 4T4R B1 20 W (AHGB)	LTE4269 SR002040	474514A	LTE 18SP	SRAN 18A
Nokia AirScale Micro 4T4R B3 20 W (AHEJ)	LTE4270 SR001791	474513A	LTE 18SP	SRAN 18A
Nokia AirScale Micro 4T4R B5 20 W (AHCE)	LTE3654 SR001791	474044A	LTE 18SP	SRAN 18A
Nokia AirScale Micro 4T4R B7 20 W (AHHA)	LTE3713 SR002039	474147A	LTE 18	SRAN 18SP
Nokia AirScale Micro 4T4R B13 20 W (AHBB)	LTE3655 SR001791	474042A	LTE 18SP	SRAN 18A

Table 7 Micro Remote Radio Heads (Cont.)

RRH name	Feature number	Product code	Introduced in LTE release	Introduced in SRAN release
Nokia AirScale Micro 4T4R B14 20 W (AHBC)	LTE5006 SR002260	474948A	LTE 19	SRAN 19
Nokia AirScale Micro 4T4R B25 20 W (AHFB)	LTE3429 SR001996	474036A	LTE 17A	SRAN 18A
AirScale Micro RRH 4T4R B41/n41 80 W (AWHHD)	LTE5161	475068A	LTE 19B MP	SRAN 19B MP
AirScale Micro RRH 4T4R B41/n41 80 W (AWHHF)	LTE5304	475181A	LTE 19A	-
Nokia AirScale Micro 4T4R B42 20 W (AZQD)	LTE4828	474798A	LTE 19	-
Nokia AirScale Micro 4T4R B43 20 W (AZQR)	LTE5235	475148A	LTE 19A	-
Nokia AirScale Micro 4T4R B66 20 W (AHIB)	LTE3431 SR002530	474050A	LTE 17A	SRAN 19A
Nokia AirScale Micro 4T4R CBRS 20 W (AZQC)	LTE3628	475148A	LTE 18SP	-

Table 8 TD-LTE Remote Radio Heads

RRH name	Feature number	Product code	Introduced in LTE release	Introduced in SRAN release
Nokia AirScale RRH 2T2R B40 120 W(AZND/AZNE)	LTE3961	474348A/474350A	LTE 18	-
Nokia AirScale RRH 4T4R B40 160 W(AZNA)	LTE2810	473914A 473914B	LTE 17A	-
Nokia AirScale RRH 4T4R B41 160 W(AZHA)	LTE3329	473941A	LTE 17A	-
Nokia AirScale RRH 8T8R B40 240W(AZNB)	LTE3549	474051A	LTE 18SP	-
Nokia AirScale RRH 8T8R B40 240 W(AZNC)	LTE3550	474052A	LTE 18	-

Table 8 TD-LTE Remote Radio Heads (Cont.)

RRH name	Feature number	Product code	Introduced in LTE release	Introduced in SRAN release
Nokia AirScale RRH 8T8R B42 160 W (AZQP)	LTE5300	475198A	LTE 19B MP	-
Nokia AirScale RRH 8T8R B42 240 W (AZQE)	LTE3736	474717A	LTE 18A	-
Nokia AirScale RRH 8T8R B42 240W(AZQF)	LTE3737	474188A	LTE 18	-

5 Nokia AirScale Macro FDD-LTE Radios

5.1 Descriptions of RF modules

5.1.1 Nokia AirScale RFM 6T6R B1/n1 480 W (ARGA)

ARGA is introduced by LTE4640, SR002273, 5GC001837: Nokia AirScale RFM 6T6R B1/n1 480 W (ARGA).

Functional description

Table 9 ARGA functional specification

Property	Value
Output power	6x80 W
QAM	256 QAM (DL) 64 QAM (UL)
Number of TXRX	6T6R
Outdoor installation	Yes
Supported technologies (standalone and MSR)	WCDMA, FDD-LTE, 5G WCDMA-LTE
TX frequency range	2110 – 2170 MHz
RX frequency range	1920 – 1980 MHz
DL filter bandwidth	60 MHz
UL filter bandwidth	60 MHz
iBW (instantaneous bandwidth)	60 MHz
oBW (occupied bandwidth)	60 MHz
Number of carriers per pipe	Up to 8 carriers in total for all supported RATs
Supported bandwidths	5, 10, 15, 20 MHz
PIM cancellation	Yes

Interfaces

Figure 4 ARGAs interfaces

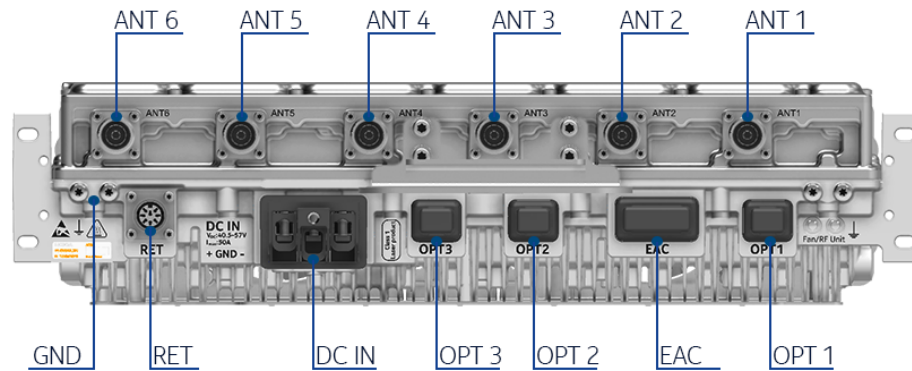



Table 10 ARGAs interfaces

Interface	Label on the HW	Number of interfaces	Connector type	Additional info
Power Connector	DC IN	1	3-pole screw terminal	Allowed wire gauge: 10 mm ² to 35 mm ² (7 AWG to 2 AWG)
Antenna connector	ANT	6	4.3-10	EMHH required for straight connectors*
Remote Electrical Tilt	RET	1	8-pin circular	RS-485; EMHH required*
External Alarm Connection	EAC	1	MDR26	4 alarm inputs and 1 control output
Optical interface	OPT	3	SFP+	9.8Gbit/s CPRI; Nokia IP seal
Grounding		1	2 x M5 screw	-

*EMHH Flexi 3U Casing and High Covers F&B (473187A) are required when connecting either 4.3-10 straight antenna cables or RET cables. For details, see *Flexi BTS Optional Items Description*.



WARNING! Risk of electric shock

Before turning RF power on, RF ports have to be terminated by nominal 50 Ω load (for example, feeder with antenna). However, if these conditions are not met, the plastic caps that are delivered within the unused RF ports should remain in place. The plastic caps isolate RF port from the environment, and thus provide electric shock security in case RF power is accidentally on.

Antenna Line Devices (ALDs) support

Table 11 ARGALD support

ALD support	Value
AISG	ANT1, ANT3, ANT5: AISG 2.0/3.0 ANT2, ANT4, ANT6: AISG 3.0 ping receiver RET: AISG 3.0
Voltage	ANT1, ANT3, ANT5, RET: 14.5 V DC
Power per port	30 W, 45 W total

Functional block diagram

Figure 5 ARGA functional block diagram

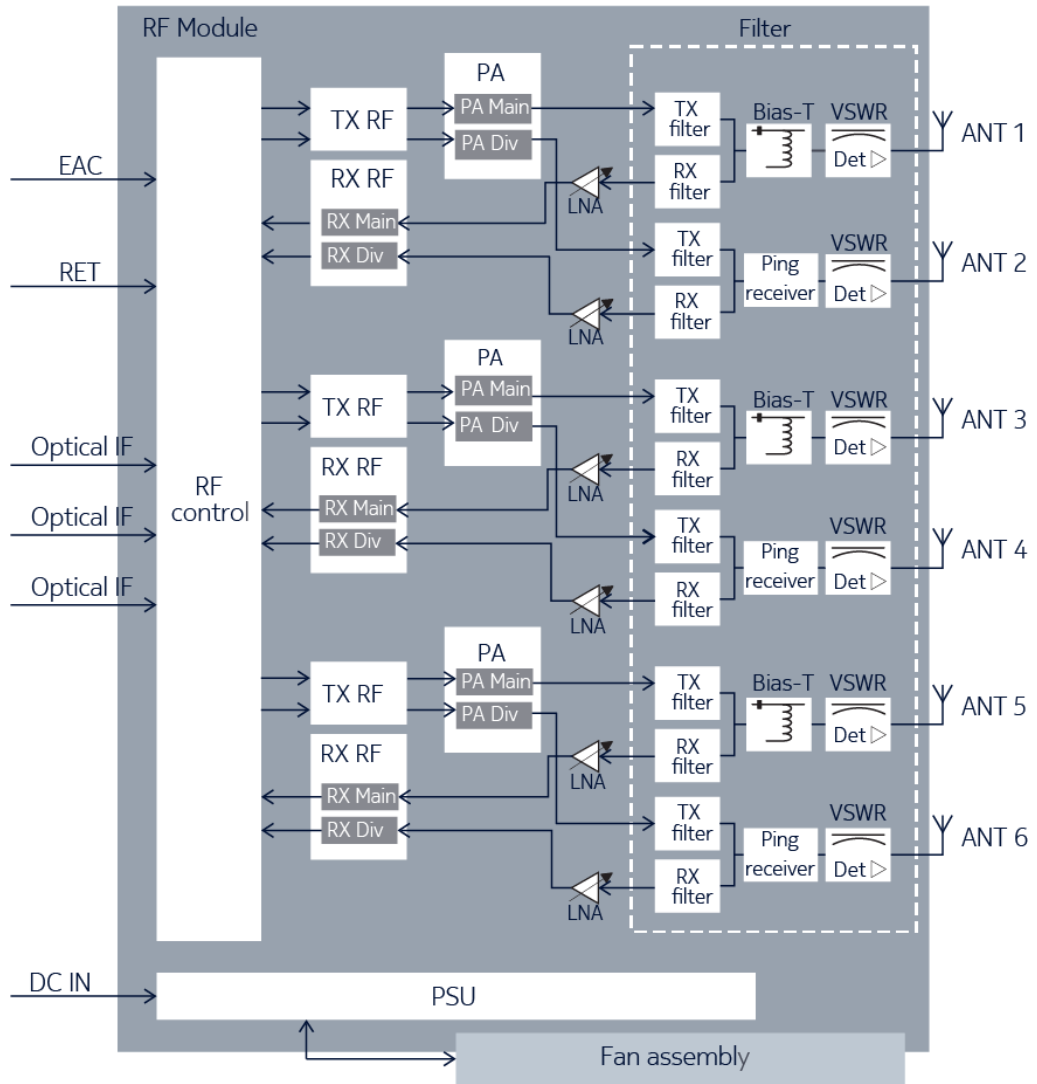

Electrical specifications

Table 12 ARGA electrical specifications

Property	Value
Nominal supply voltage	-48.0 V DC
Nominal input voltage range	-40.5 V DC to -57.0 V DC
Extended input voltage range	-36.0 V DC to -40.5 V DC -57.0 V DC to -60.0 V DC
Surge protection	Class II 5kA



Note: The minimum start-up voltage is -40.5 V DC. If the input voltage is below/beyond the extended limits, the unit might shut down.

Table 13 ARGAs TX output power tolerance

Property	Value	Description
Typical power tolerance (nominal temperature)	± 0.8 dB	Over full TX RF bandwidth, nominal ambient temperature 25°C (77°F)
Typical power tolerance (extreme temperature)	± 2.0 dB	Over full TX RF bandwidth, extreme ambient temperature 55°C (131°F)

Power consumption

Typical power consumption [W] for 48VDC input, at 25°C, representative of typical product performance under the same conditions (HW variant, SW version, configuration, environment, and so on) with +/- 10% margin. Average = (6h low hour load, 10h medium hour load and 8h busy hour load) / 24h

Configurations explained on examples:

- GSM/WCDMA: 2/2/2 = three sectors, two carriers/TRXs per sector
- LTE:
 - o 2/2/2 2Tx = three sectors, two carriers per sector, 2Tx per carrier
 - o 1+1/1+1/1+1 4Tx = three dual-band sectors, one carrier per sector per band, 4Tx per carrier

Some radio units are capable of providing only one sector coverage. Then the power values in the table consider deployment of three radio units.

Table 14 ARGAs power consumption in LTE mode

Configuration	Output Power per carrier (W)	Power consumption (W), ETSI 202706 average load $P_{RRH, static}$	Power consumption (W), ETSI 202706 busy hour load $P_{BH, RRH, static}$	Power consumption (W), 100% RF power load $P_{100\% RRH}$
1/1/1 2Tx	2x80	716	940	1510
1/1/1 2Tx	2x60	615	786	1210
1/1/1 2Tx	2x40	485	600	881
1/1/1 2Tx	2x30	440	529	739
1/1/1 2Tx	2x20	373	436	582

Power reduction

Table 15 Recommended ARGAs power reduction in 256 QAM mode

Rated power [W]	Single carrier [dB]	Dual carrier [dB]
80	0.6	1.2
≤60	0	0.6



Note: The maximum power reduction (`dlCellPwrRed`) value is 20 dB. High power reduction values may cause radio outages.

Related optional items

- AMFN AirScale 2 Casing Adapter RRH 300 (474664A)
- ASAA AirScale 2 MDR26-open EAC cable 5 m (474288A)
- EMHA Flexi 3U Mounting Cover (470316A)
- EMHH Flexi 3U High Mounting Cover (473187A)
- FMAA Flexi Mounting Auxiliary Bracket (471657A)
- FMFA Flexi Mounting Kit for Floor, Wall and Pole (470149A)
- FMHA Flexi Side Covers (471524A)
- FPKA Flexi Pole Mounting Kit (30-120 mm) (471649A)
- AMRM AirScale one clip kit for RF modules (475018A)
- AMRC AirScale one clip rail 600 mm (474583A)
- FPKC Flexi Pole Mounting Kit (60-300 mm) (472821A)
- FSEP Flexi System External OVP (473246A)
- FSES Flexi System External OVP (472285A)

Installation options

- Pole (vertical)
- Wall (vertical)
- Stack
- Inside cabinet
- One-clip rail installation

Dimensions and weight

Table 16 ARGA dimensions and weight

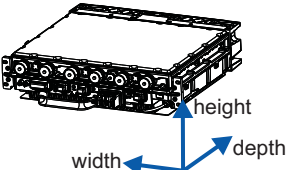
Property	Value	Dimensions orientation
Height	118 mm (4.65 in.)	
Depth	402 mm (15.83 in.)	
Width	441 mm (17.36 in.)	
Weight	23 kg (50.7 lb)	

Environmental specifications

Table 17 ARGA environmental specifications

Property	Value
Maximum operational outdoor temperature (in the shade)	55°C (131°F)
Maximum operational outdoor temperature (in the sun)	55°C (131°F)
Maximum indoor temperature	55°C (113°F)
Minimum operational temperature	-40°C (-40°F)
IP rating	IP65

LTE4640 feature interdependencies

The *LTE4640: Nokia AirScale RFM 6T6R B1 480 W (ARGA)* feature is impacted by the following features:

- *LTE112: Cell Bandwidth - 20 MHz*
Needs to be enabled to use LTE 20 MHz carriers.
- *LTE113: Cell Bandwidth - 15 MHz*
Needs to be enabled to use LTE 15 MHz carriers.
- *LTE114: Cell Bandwidth - 10 MHz*
Needs to be enabled to use LTE 10 MHz carriers.
- *LTE115: Cell Bandwidth - 5 MHz*
Needs to be enabled to use LTE 5 MHz carriers.
- *With LTE614: Distributed Site,*
ARGA can be used in distributed sites with up to 23 km fiber length to the system module.
- *LTE1103: Load based Power Saving for multi-layer networks*
Needs to be enabled to use Load based Power Saving for multi-layer networks.
- *LTE1203: Load based Power Saving with Tx path switching off*
Needs to be enabled to use Load based Power Saving with Tx path switching off.
- *LTE2428: Nokia CPRI in FDD-LTE*
Provides support for CPRI interface.
- *LTE2508: BTS Embedded Power Meter for Energy Efficiency Monitoring*
Needs to be enabled to use BTS Embedded Power Meter for Energy Efficiency Monitoring.
- *LTE2541: Nokia CPRI RRH/RFM chaining*
Provides support for chaining.
- *LTE3036: Micro DTX extension*
Needs to be enabled to use Micro DTX extension.
- *LTE3037: Power Saving - Slow Drain Voltage Modulation*
Needs to be enabled to use Load based PA efficiency improvement.

SR002273 feature interdependencies

The *SR002273: Nokia AirScale RFM 6T6R B1 480 W (ARGA)* feature is impacted by the following features:

- *With RP000635: Radio Module Remote Reset,*
malfunctioning or not responding ARGA module can be reset remotely.

5.1.2 Nokia AirScale RFM 6T6R B3/n3 480 W (AREA)

AREA is introduced by LTE4208, SR001943, 5GC001694: Nokia AirScale RFM 6T6R B3/n3 480 W (AREA).

Functional description

Table 18 AREA functional specification

Property	Value
Output power	6x80 W
QAM	256 QAM (DL) 64 QAM (UL)

Table 18 AREA functional specification (Cont.)

Property	Value
Number of TXRX	6T6R
Outdoor installation	Yes
Supported technologies (standalone and MSR)	GSM, FDD-LTE, 5G GSM-LTE
TX frequency range	1805 – 1880 MHz
RX frequency range	1710 – 1785 MHz
DL filter bandwidth	75 MHz
UL filter bandwidth	75 MHz
iBW (instantaneous bandwidth)	75 MHz
oBW (occupied bandwidth)	75 MHz
Number of carriers per pipe	Up to 8 carriers in total for all supported RATs
Supported bandwidths	LTE: 1.4, 3, 5, 10, 15, 20 MHz 5G: 5, 10, 15, 20 MHz
PIM cancellation	Yes

Interfaces

Figure 6 AREA interfaces

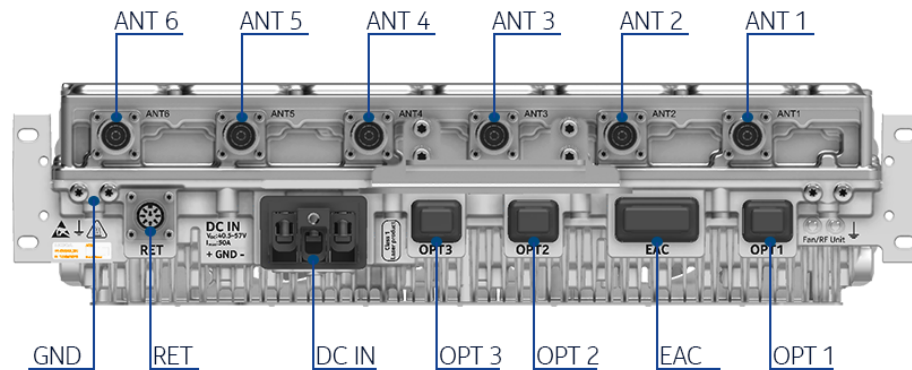



Table 19 AREA interfaces

Interface	Label on the HW	Number of interfaces	Connector type	Additional info
Power Connector	DC IN	1	3-pole screw terminal	Allowed wire gauge: 10 mm ² to 35 mm ² (7 AWG to 2 AWG)
Antenna connector	ANT	6	4.3-10	EMHH required for straight connectors*
Remote Electrical Tilt	RET	1	8-pin circular	RS-485; EMHH required*
LMI (Local Management Interface and EAC)	EAC	1	MDR26	4 alarm inputs and 1 control output
Optical interface	OPT	3	SFP+	9.8Gbit/s CPRI; Nokia IP seal
Grounding		1	2 x M5 screw	-

*EMHH Flexi 3U Casing and High Covers F&B (473187A) are required when connecting either 4.3-10 straight antenna cables or RET cables. For details, see *Flexi BTS Optional Items Description*.



WARNING! Risk of electric shock

Before turning RF power on, RF ports have to be terminated by nominal 50 Ω load (for example, feeder with antenna). However, if these conditions are not met, the plastic caps that are delivered within the unused RF ports should remain in place. The plastic caps isolate RF port from the environment, and thus provide electric shock security in case RF power is accidentally on.

Antenna Line Devices (ALDs) support

Table 20 AREA ALD support

ALD support	Value
AISG	ANT1, ANT3, ANT5: AISG 2.0/3.0 ANT2, ANT4, ANT6: AISG 3.0 ping receiver RET: AISG 3.0
Voltage	ANT1, ANT3, ANT5, RET: 14.5 V DC
Power per port	30 W, 45 W total

Functional block diagram

Figure 7 AREA functional block diagram

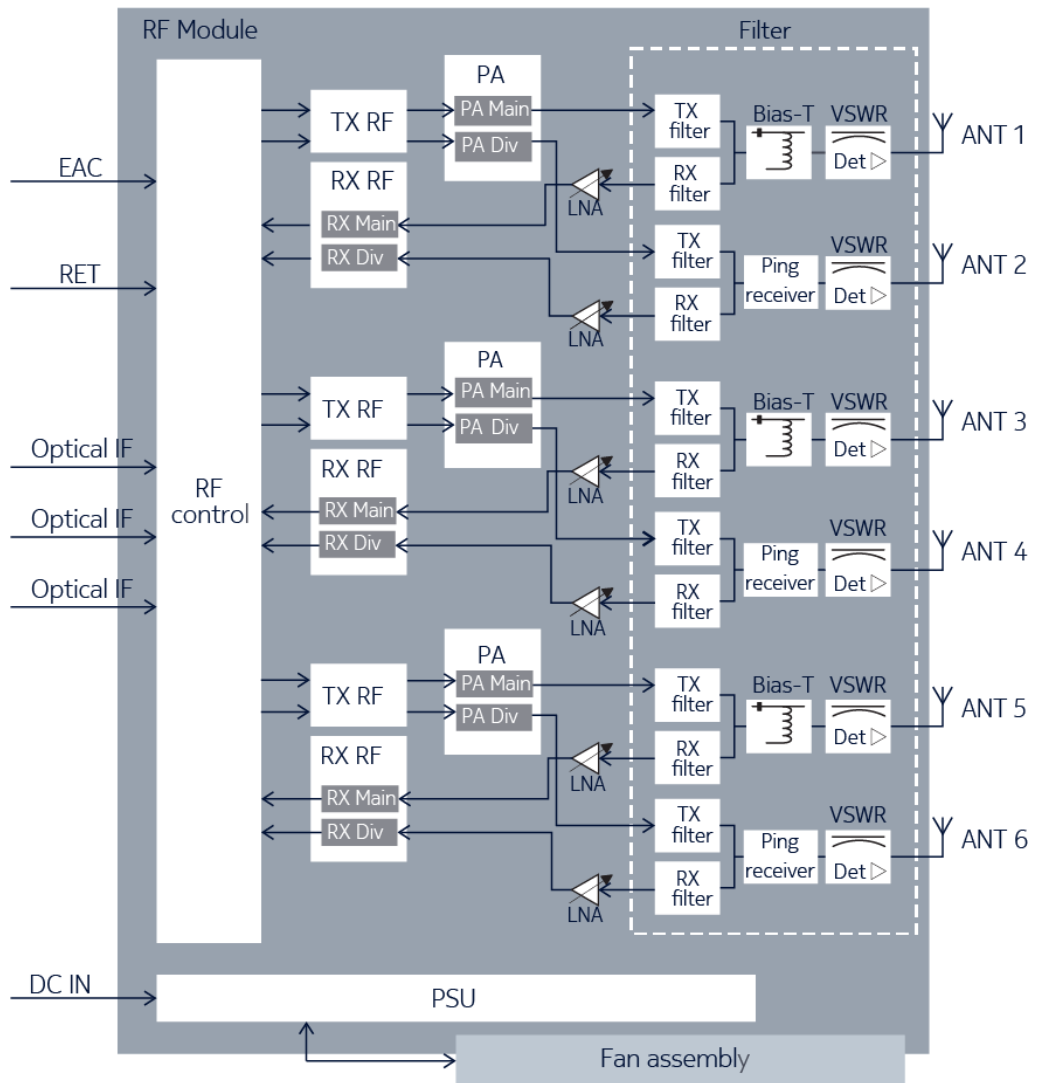

Electrical specifications

Table 21 AREA electrical specifications

Property	Value
Nominal supply voltage	-48.0 V DC
Nominal input voltage range	-40.5 V DC to -57.0 V DC
Extended input voltage range	-36.0 V DC to -40.5 V DC -57.0 V DC to -60.0 V DC
Surge protection	Class II 5kA



Note: The minimum start-up voltage is -40.5 V DC. If the input voltage is below/beyond the extended limits, the unit might shut down.

Table 22 AREA TX output power tolerance

Property	Value	Description
Typical power tolerance (nominal temperature)	± 0.8 dB	Over full TX RF bandwidth, nominal ambient temperature 25°C (77°F)
Typical power tolerance (extreme temperature)	± 2.0 dB	Over full TX RF bandwidth, extreme ambient temperature 55°C (131°F)

Power consumption

Typical power consumption [W] for 48VDC input, at 25°C, representative of typical product performance under the same conditions (HW variant, SW version, configuration, environment, and so on) with +/- 10% margin. Average = (6h low hour load, 10h medium hour load and 8h busy hour load) / 24h

Configurations explained on examples:

- GSM/WCDMA: 2/2/2 = three sectors, two carriers/TRXs per sector
- LTE:
 - o 2/2/2 2Tx = three sectors, two carriers per sector, 2Tx per carrier
 - o 1+1/1+1/1+1 4Tx = three dual-band sectors, one carrier per sector per band, 4Tx per carrier

Some radio units are capable of providing only one sector coverage. Then the power values in the table consider deployment of three radio units.

Table 23 AREA power consumption in LTE mode

Configuration	Output Power per carrier (W)	Power consumption (W), ETSI 202706 average load P _{RRH} , static	Power consumption (W), ETSI 202706 busy hour load P _{BH} RRH, static	Power consumption (W), 100% RF power load P _{100% RRH}
1/1/1 2Tx	2x80	762	971	1481
1/1/1 2Tx	2x60	687	846	1216
1/1/1 2Tx	2x40	531	636	869
1/1/1 2Tx	2x30	491	575	750
1/1/1 2Tx	2x20	418	477	593

Power reduction

Table 24 Recommended AREA power reduction in 256 QAM

Rated power [W]	Single carrier [dB]	Dual carrier [dB]
80	0.6	1.2
≤60	0	0.6



Note: The maximum power reduction (dlCellPwrRed) value is 20 dB. High power reduction values may cause radio outages.

Related optional items

- AMFN AirScale 2 Casing Adapter RRH 300 (474664A)
- ASAA AirScale 2 MDR26-open EAC cable 5 m (474288A)
- EMHA Flexi 3U Mounting Cover (470316A)
- EMHH Flexi 3U High Mounting Cover (473187A)
- FMAA Flexi Mounting Auxiliary Bracket (471657A)
- FMFA Flexi Mounting Kit for Floor, Wall and Pole (470149A)
- FMHA Flexi Side Covers (471524A)
- FPKA Flexi Pole Mounting Kit (30-120 mm) (471649A)
- AMRM AirScale one clip kit for RF modules (475018A)
- AMRC AirScale one clip rail 600 mm (474583A)
- FPKC Flexi Pole Mounting Kit (60-300 mm) (472821A)
- FSEP Flexi System External OVP (473246A)
- FSES Flexi System External OVP (472285A)

Installation options

- Pole (vertical)
- Wall (vertical)
- Stack
- Inside cabinet
- One-clip rail installation

Dimensions and weight

Table 25 AREA dimensions and weight

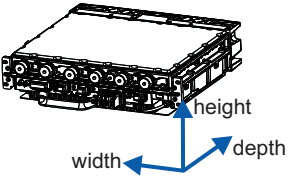
Property	Value	Dimensions orientation
Height	118 mm (4.65 in.)	
Depth	402 mm (15.83 in.)	
Width	441 mm (17.36 in.)	
Weight	23 kg (50.7 lb)	

Environmental specifications

Table 26 AREA environmental specifications

Property	Value
Maximum operational outdoor temperature (in the shade)	55°C (131°F)
Maximum operational outdoor temperature (in the sun)	55°C (131°F)
Maximum indoor temperature	55°C (113°F)
Minimum operational temperature	-40°C (-40°F)
IP rating	IP65

LTE4208 feature interdependencies

The *LTE4208: Nokia AirScale RFM 6T6R B3 480W (AREA)* feature is impacted by the following features:

- *LTE112: Cell Bandwidth - 20 MHz*
Needs to be enabled to use LTE 20 MHz carriers.
- *LTE113: Cell Bandwidth - 15 MHz*
Needs to be enabled to use LTE 15 MHz carriers.
- *LTE114: Cell Bandwidth - 10 MHz*
Needs to be enabled to use LTE 10 MHz carriers.
- *LTE115: Cell Bandwidth - 5 MHz*
Needs to be enabled to use LTE 5 MHz carriers.
- *LTE116: Cell Bandwidth - 3 MHz*
Needs to be enabled to use LTE 3 MHz carriers.
- *LTE117: Cell Bandwidth - 1.4 MHz*
Needs to be enabled to use LTE 1.4 MHz carriers.
- *With LTE614: Distributed Site,*
AREA can be used in distributed sites with up to 23 km fiber length to the system module.
- *LTE1103: Load based Power Saving for multi-layer networks*
Needs to be enabled to use Load based Power Saving for multi-layer networks.
- *LTE1203: Load based Power Saving with Tx path switching off*
Needs to be enabled to use Load based Power Saving with Tx path switching off.
- *LTE2428: Nokia CPRI in FDD-LTE*
Provides support for CPRI interface.
- *LTE2508: BTS Embedded Power Meter for Energy Efficiency Monitoring*
Needs to be enabled to use BTS Embedded Power Meter for Energy Efficiency Monitoring.
- *LTE2541: Nokia CPRI RRH/RFM chaining*
Provides support for chaining.
- *LTE2553: OBSAI chaining to 9.8G CPRI link*
AREA supports chaining of legacy OBSAI radio units with Nokia CPRI radio modules.
- *LTE3036: Micro DTX extension*
Needs to be enabled to use Micro DTX extension.

5.1.3 Nokia AirScale RFM 6T6R B5 480 W (ARCA)

ARCA is introduced by LTE4662/SR002152: Nokia AirScale RFM 6T6R B5 480 W (ARCA).

Functional description

Table 27 ARCA functional specification

Property	Value
Output power	6x80 W
QAM	256 QAM (DL) 64 QAM (UL)
Number of TXRX	6T6R
Outdoor installation	Yes

Table 27 ARCA functional specification (Cont.)

Property	Value
Supported technologies (standalone and MSR)	GSM, WCDMA, FDD-LTE, 5G-ready GSM-WCDMA, WCDMA-LTE, GSM-LTE, GSM-WCDMA-LTE
TX frequency range	869 - 894 MHz
RX frequency range	824 - 849 MHz
DL filter bandwidth	25 MHz
UL filter bandwidth	25 MHz
iBW (instantaneous bandwidth)	25 MHz
oBW (occupied bandwidth)	25 MHz
Supported bandwidths	1.4, 3, 5, 10 MHz
PIM cancellation	Yes

Interfaces

Figure 8 ARCA interfaces

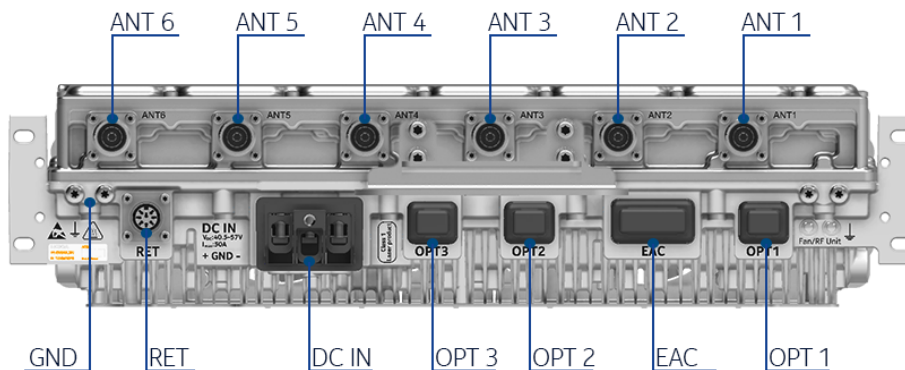



Table 28 ARCA interfaces

Interface	Label on the HW	Number of interfaces	Connector type	Additional info
Power Connector	DC IN	1	3-pole screw terminal	Allowed wire gauge: 10 mm ² to 35 mm ² (7 AWG to 2 AWG)
Antenna connector	ANT	6	4.3-10	EMHH required for straight connectors*
Remote Electrical Tilt	RET	1	8-pin circular	RS-485; EMHH required*
External Alarm Connection	EAC	1	MDR26	4 alarm inputs and 1 control output
Optical interface	OPT	3	SFP+	9.8Gbit/s CPRI; Nokia IP seal
Grounding		1	2 x M5 screw	-

*EMHH Flexi 3U Casing and High Covers F&B (473187A) are required when connecting either 4.3-10 straight antenna cables or RET cables. For details, see *Flexi BTS Optional Items Description*.



WARNING! Risk of electric shock

Before turning RF power on, RF ports have to be terminated by nominal 50 Ω load (for example, feeder with antenna). However, if these conditions are not met, the plastic caps that are delivered within the unused RF ports should remain in place. The plastic caps isolate RF port from the environment, and thus provide electric shock security in case RF power is accidentally on.

Antenna Line Devices (ALDs) support

Table 29 ARCA ALD support

ALD support	Value
AISG	ANT1, ANT3, ANT5: AISG 2.0/3.0 ANT2, ANT4, ANT6: AISG 3.0 ping receiver RET: AISG 3.0
Voltage	ANT1, ANT3, ANT5, RET: 14.5 V DC
Power per port	30 W, 45 W total

Functional block diagram

Figure 9 ARCA functional block diagram

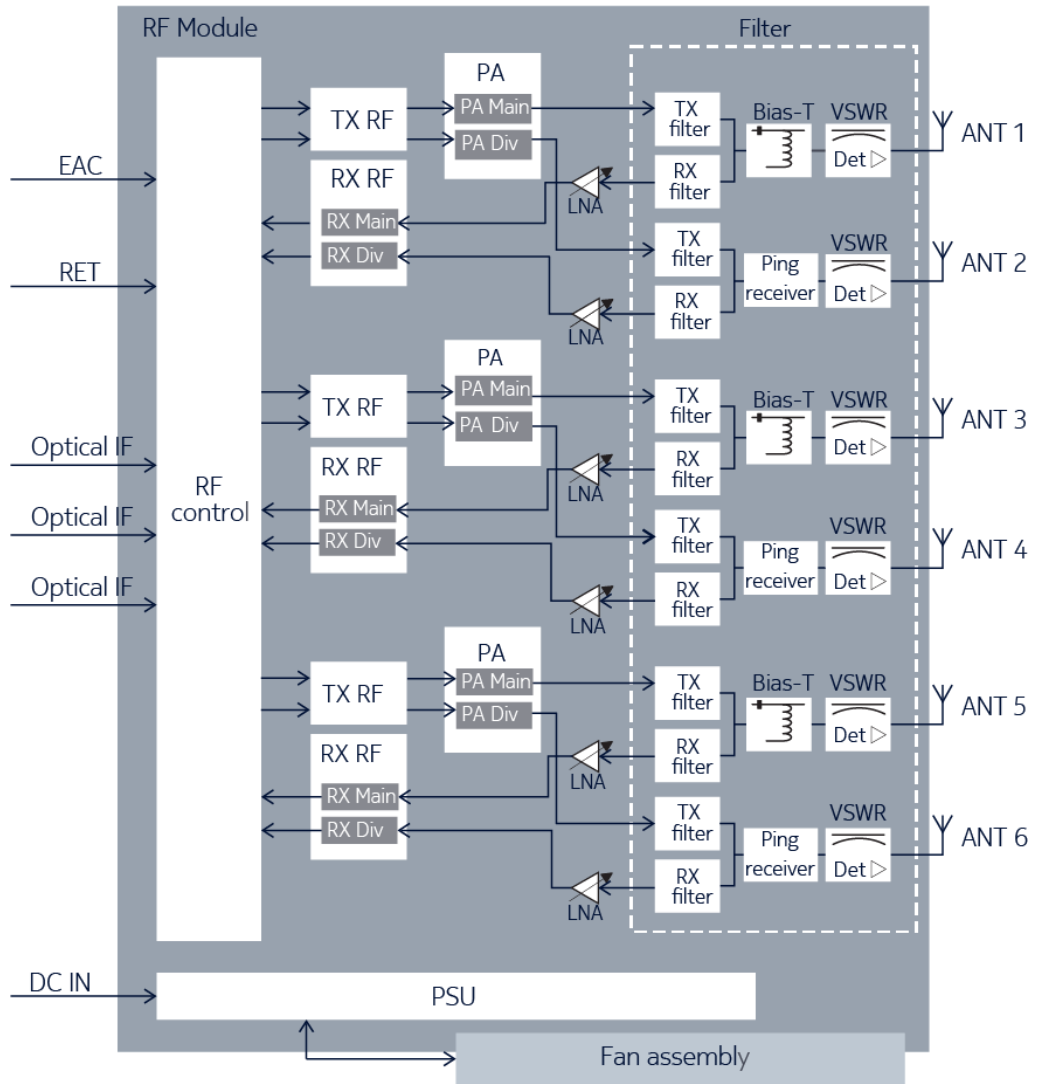

Electrical specifications

Table 30 ARCA electrical specifications

Property	Value
Nominal supply voltage	-48.0 V DC
Nominal input voltage range	-40.5 V DC to -57.0 V DC
Extended input voltage range	-36.0 V DC to -40.5 V DC -57.0 V DC to -60.0 V DC
Surge protection	Class II 5kA



Note: The minimum start-up voltage is -40.5 V DC. If the input voltage is below/beyond the extended limits, the unit might shut down.

Table 31 ARCA TX output power tolerance

Property	Value	Description
Typical power tolerance (nominal temperature)	± 0.8 dB	Over full TX RF bandwidth, nominal ambient temperature 25°C (77°F)
Typical power tolerance (extreme temperature)	± 2.0 dB	Over full TX RF bandwidth, extreme ambient temperature 55°C (131°F)

Power consumption

Typical power consumption [W] for 48VDC input, at 25°C, representative of typical product performance under the same conditions (HW variant, SW version, configuration, environment, and so on) with +/- 10% margin. Average = (6h low hour load, 10h medium hour load and 8h busy hour load) / 24h

Configurations explained on examples:

- GSM/WCDMA: 2/2/2 = three sectors, two carriers/TRXs per sector
- LTE:
 - o 2/2/2 2Tx = three sectors, two carriers per sector, 2Tx per carrier
 - o 1+1/1+1/1+1 4Tx = three dual-band sectors, one carrier per sector per band, 4Tx per carrier

Some radio units are capable of providing only one sector coverage. Then the power values in the table consider deployment of three radio units.

Table 32 ARCA power consumption in LTE mode

Configuration	Output Power per carrier (W)	Power consumption (W), ETSI 202706 average load $P_{RRH, static}$	Power consumption (W), ETSI 202706 busy hour load $P_{BH, RRH, static}$	Power consumption (W), 100% RF power load $P_{100\% RRH}$
1/1/1 2Tx	2x80	724	929	1441
1/1/1 2Tx	2x60	643	800	1183
1/1/1 2Tx	2x40	515	616	861
1/1/1 2Tx	2x30	475	555	739
1/1/1 2Tx	2x20	389	444	564

Power reduction

Table 33 Recommended ARCA power reduction in 256 QAM mode

Rated power [W]	Single carrier [dB]	Dual carrier [dB]
80	0.6	1.2
≤60	0	0.6



Note: The maximum power reduction (dlCellPwrRed) value is 20 dB. High power reduction values may cause radio outages.

Related optional items

- AMFN AirScale 2 Casing Adapter RRH 300 (474664A)
- ASAA AirScale 2 MDR26-open EAC cable 5 m (474288A)
- EMHA Flexi 3U Mounting Cover (470316A)
- EMHH Flexi 3U High Mounting Cover (473187A)
- FMAA Flexi Mounting Auxiliary Bracket (471657A)
- FMFA Flexi Mounting Kit for Floor, Wall and Pole (470149A)
- FMHA Flexi Side Covers (471524A)
- FPKA Flexi Pole Mounting Kit (30-120 mm) (471649A)
- AMRM AirScale one clip kit for RF modules (475018A)
- AMRC AirScale one clip rail 600 mm (474583A)
- FPKC Flexi Pole Mounting Kit (60-300 mm) (472821A)
- FSEP Flexi System External OVP (473246A)
- FSES Flexi System External OVP (472285A)

Installation options

- Pole (vertical)
- Wall (vertical)
- Stack
- Inside cabinet
- One-clip rail installation

Dimensions and weight

Table 34 ARCA dimensions and weight

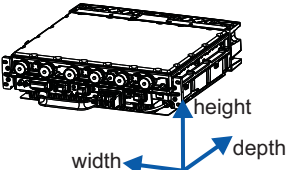
Property	Value	Dimensions orientation
Height	118 mm (4.65 in.)	
Depth	402 mm (15.83 in.)	
Width	441 mm (17.36 in.)	
Weight	23 kg (50.7 lb)	

Environmental specifications

Table 35 ARCA environmental specifications

Property	Value
Maximum operational outdoor temperature (in the shade)	55°C (131°F)
Maximum operational outdoor temperature (in the sun)	55°C (131°F)
Maximum indoor temperature	55°C (113°F)
Minimum operational temperature	-40°C (-40°F)
IP rating	IP65

LTE4662 feature interdependencies

The LTE4662: *Nokia AirScale RFM 6T6R B5 480 W (ARCA)* feature is impacted by the following features:

- *LTE114: Cell Bandwidth - 10 MHz*
Needs to be enabled to use LTE 10 MHz carriers.
- *LTE115: Cell Bandwidth - 5 MHz*
Needs to be enabled to use LTE 5 MHz carriers.
- *LTE116: Cell Bandwidth - 3 MHz*
Needs to be enabled to use LTE 3 MHz carriers.
- *LTE117: Cell Bandwidth - 1.4 MHz*
Needs to be enabled to use LTE 1.4 MHz carriers.
- *With LTE614: Distributed Site,*
ARCA can be used in distributed sites with up to 23 km fiber length to the system module.
- *LTE1103: Load based Power Saving for multi-layer networks*
Needs to be enabled to use Load based Power Saving for multi-layer networks.
- *LTE1203: Load based Power Saving with Tx path switching off*
Needs to be enabled to use Load based Power Saving with Tx path switching off.
- *LTE2428: Nokia CPRI in FDD-LTE*
Provides support for CPRI interface.
- *LTE2508: BTS Embedded Power Meter for Energy Efficiency Monitoring*
Needs to be enabled to use BTS Embedded Power Meter for Energy Efficiency Monitoring.
- *LTE2541: Nokia CPRI RRH/RFM chaining*
Provides support for chaining.
- *LTE3036: Micro DTX extension*
Needs to be enabled to use Micro DTX extension.
- *LTE3037: Power Saving - Slow Drain Voltage Modulation*
Needs to be enabled to use Load based PA efficiency improvement.

SR002152 feature interdependencies

The *SR002152: Nokia AirScale RFM 6T6R B5 480 W (ARCA)* feature is impacted by the following features:

- *With RP000635: Radio Module Remote Reset,*
malfunctioning or not responding ARCA module can be reset remotely.

5.1.4 Nokia AirScale RFM 6T6R B7 360 W (ARHA)

ARHA is introduced by LTE4641: AirScale RFM 6T6R B7 360 W (ARHA).

Functional description

Table 36 ARHA functional specification

Property	Value
Output power	6x60 W
QAM	256 QAM (DL) 64 QAM (UL)
Number of TXRX	6T6R

Table 36 ARHA functional specification (Cont.)

Property	Value
Outdoor installation	Yes
Supported technologies (standalone and MSR)	FDD-LTE, 5G-ready
TX frequency range	2620 - 2690 MHz
RX frequency range	2500 - 2570 MHz
DL filter bandwidth	70 MHz
UL filter bandwidth	70 MHz
iBW (instantaneous bandwidth)	70 MHz
oBW (occupied bandwidth)	70 MHz
Supported bandwidths	5, 10, 15, 20 MHz
PIM cancellation	Yes

Interfaces

Figure 10 ARHA interfaces

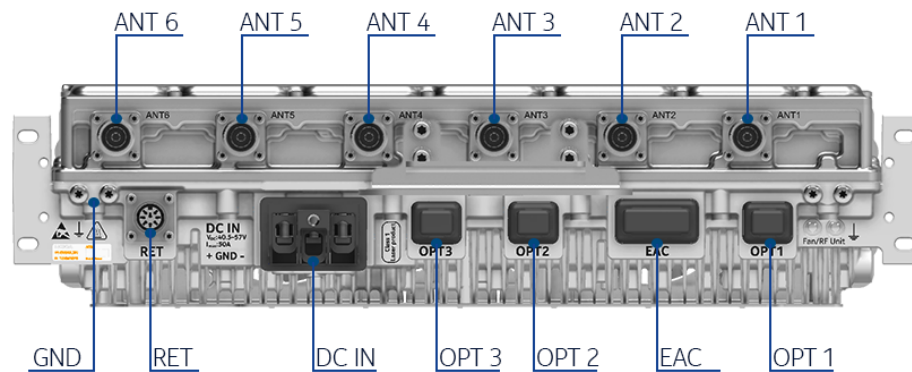



Table 37 ARHA interfaces

Interface	Label on the HW	Number of interfaces	Connector type	Additional info
Power Connector	DC IN	1	3-pole screw terminal	Allowed wire gauge: 10 mm ² to 35 mm ² (7 AWG to 2 AWG)

Table 37 ARHA interfaces (Cont.)

Interface	Label on the HW	Number of interfaces	Connector type	Additional info
Antenna connector	ANT	6	4.3-10	EMHH required for straight cables*
Remote Electrical Tilt	RET	1	8-pin circular	RS-485; EMHH required*
External Alarm Connection	EAC	1	MDR26	4 alarm inputs and 1 control output
Optical interface	OPT	3	SFP+	9.8 Gbit/s CPRI; Nokia IP seal
Grounding		1	2 x M5 screw	-

*EMHH Flexi 3U Casing and High Covers F&B (473187A) are required when connecting either 4.3-10 straight antenna cables or RET cables. For details, see *Flexi BTS Optional Items Description*.



WARNING! Risk of electric shock

Before turning RF power on, RF ports have to be terminated by nominal 50 Ω load (for example, feeder with antenna). However, if these conditions are not met, the plastic caps that are delivered within the unused RF ports should remain in place. The plastic caps isolate RF port from the environment, and thus provide electric shock security in case RF power is accidentally on.

Antenna Line Devices (ALDs) support

Table 38 ARHA ALD support

ALD supports	Value
AISG	ANT1, ANT3, ANT5: AISG 2.0/3.0 ANT2, ANT4, ANT6: AISG 3.0 ping receiver RET: AISG 3.0
Voltage	ANT1, ANT3, ANT5, RET: 14.5 V DC
Power per port	30 W, 45 W total

Functional block diagram

Figure 11 ARHA functional block diagram

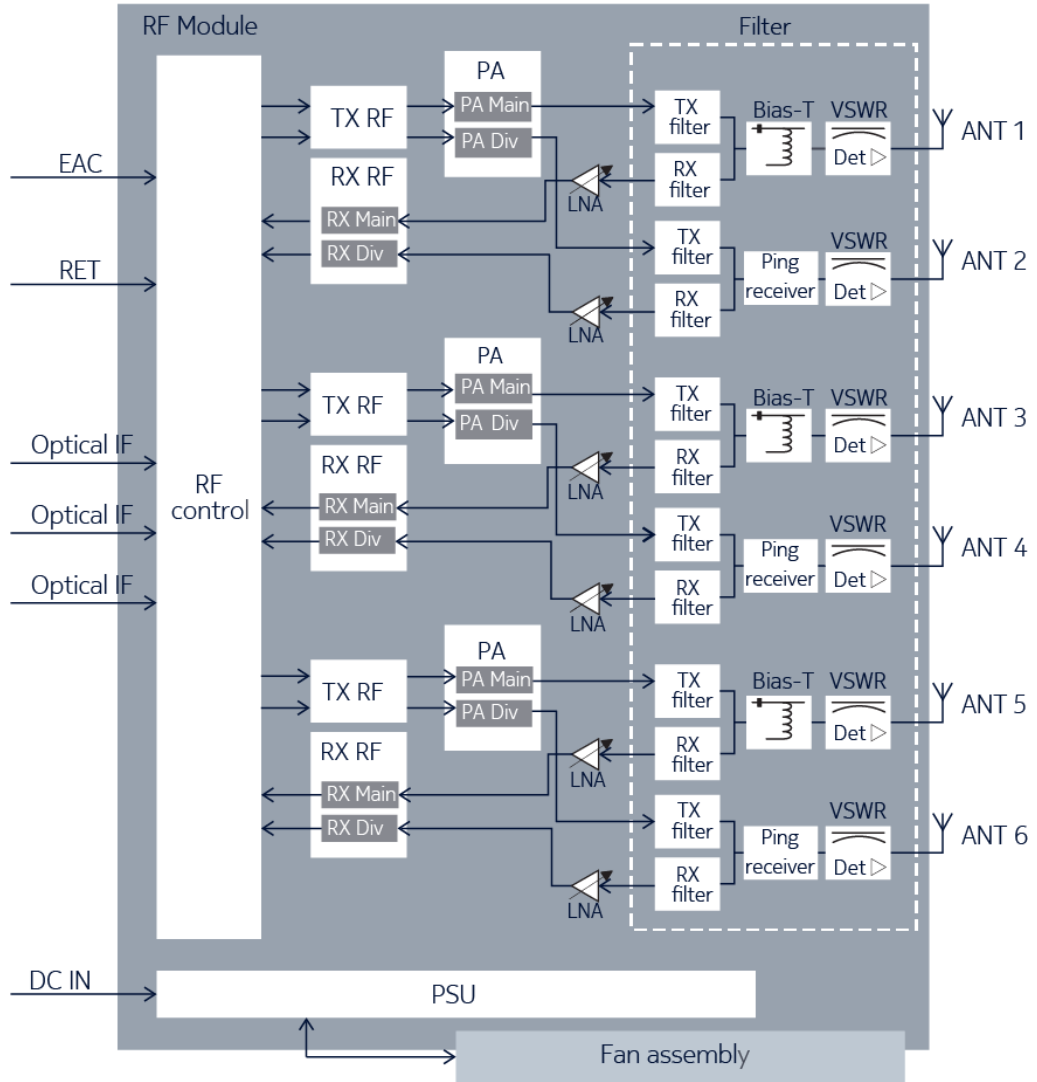

Electrical specifications

Table 39 ARHA electrical specifications

Property	Value
Nominal supply voltage	-48.0 V DC
Nominal input voltage range	-40.5 V DC to -57.0 V DC
Extended input voltage range	-36.0 V DC to -40.5 V DC -57.0 V DC to -60.0 V DC



Note: The minimum start-up voltage is -40.5 V DC. If the input voltage is below/beyond the extended limits, the unit might shut down.

Table 40 ARHA TX output power tolerance

Property	Value	Description
Typical power tolerance (nominal temperature)	± 0.8 dB	Over full TX RF bandwidth, nominal ambient temperature 25°C (77°F)
Typical power tolerance (extreme temperature)	± 2.0 dB	Over full TX RF bandwidth, extreme ambient temperature 55°C (131°F)

Power consumption



Note: ARHA power consumption will be provided in future releases.

Power reduction

Table 41 Recommended ARHA power reduction in 256 QAM mode

Rated power [W]	Single carrier [dB]	Dual carrier [dB]
60	0	0.6



Note: The maximum power reduction (`dlCellPwrRed`) value is 20 dB. High power reduction values may cause radio outages.

Related optional items

- AMFN AirScale 2 Casing Adapter RRH 300 (474664A)
- ASAA AirScale 2 MDR26-open EAC cable 5 m (474288A)
- EMHA Flexi 3U Mounting Cover (470316A)
- EMHH Flexi 3U High Mounting Cover (473187A)
- FMAA Flexi Mounting Auxiliary Bracket (471657A)
- FMFA Flexi Mounting Kit for Floor, Wall and Pole (470149A)
- FMHA Flexi Side Covers (471524A)
- FPKA Flexi Pole Mounting Kit (30-120 mm) (471649A)
- AMRM AirScale one clip kit for RF modules (475018A)
- AMRC AirScale one clip rail 600 mm (474583A)
- FPKC Flexi Pole Mounting Kit (60-300 mm) (472821A)
- FSEP Flexi System External OVP (473246A)
- FSES Flexi System External OVP (472285A)

Installation options

- Pole (vertical)
- Wall (vertical)
- Stack
- Inside a cabinet
- One-clip rail installation

Dimensions and weight

Table 42 ARHA dimensions and weight

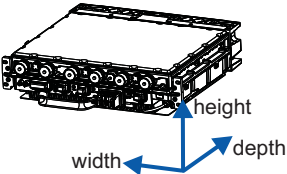
Property	Value	Dimensions orientation
Height	118 mm (4.65 in.)	
Depth	402 mm (15.83 in.)	
Width	441 mm (17.36 in.)	
Weight	23 kg (50.7 lb)	

Environmental specifications

Table 43 ARHA environmental specifications

Property	Value
Maximum operational outdoor temperature (in the shade)	55°C (131°F)
Maximum operational outdoor temperature (in the sun)	55°C (131°F)
Maximum indoor temperature	55°C (113°F)
Minimum operational temperature	-40°C (-40°F)
IP rating	IP65

LTE4641 feature interdependencies

The *LTE4641: Nokia AirScale RFM 6T6R B7 360 W (ARHA)* feature is impacted by the following features:

- *LTE112: Cell Bandwidth - 20 MHz*
Needs to be enabled to use LTE 20 MHz carriers.
- *LTE113: Cell Bandwidth - 15 MHz*
Needs to be enabled to use LTE 15 MHz carriers.
- *LTE114: Cell Bandwidth - 10 MHz*
Needs to be enabled to use LTE 10 MHz carriers.
- *LTE115: Cell Bandwidth - 5 MHz*
Needs to be enabled to use LTE 5 MHz carriers.
- With *LTE614: Distributed Site*,
ARHA can be used in distributed sites with up to 23 km (14.51 mi) fiber length to the system module.
- *LTE1103: Load based Power Saving for multi-layer networks*
Needs to be enabled to use Load based Power Saving for multi-layer networks.
- *LTE1203: Load based Power Saving with Tx path switching off*
Needs to be enabled to use Load based Power Saving with Tx path switching off.
- *LTE2508: BTS Embedded Power Meter for Energy Efficiency Monitoring*
Needs to be enabled to use BTS Embedded Power Meter for Energy Efficiency Monitoring.
- *LTE2541: Nokia CPRI RRH/RFM chaining*
Provides support for chaining.
- *LTE3036: Micro DTX extension*
Needs to be enabled to use Micro DTX extension.

- *LTE3037: Power Saving - Slow Drain Voltage Modulation*
Needs to be enabled to use Load based PA efficiency improvement - SDVM.

5.1.5 Nokia AirScale RFM 6T6R B8 480 W (ARDA)

ARDA is introduced by SR002611: MSR support for AirScale RFM 6T6R B8 480 W ARDA.

Functional description

Table 44 ARDA functional specification

Property	Value
Output power	6x80 W
QAM	256 QAM (DL) 64 QAM (UL)
Number of TXRX	6T6R
Outdoor installation	Yes
Supported technologies (standalone and MSR)	GSM, WCDMA, FDD-LTE, 5G-ready GSM-WCDMA, WCDMA-LTE, GSM-LTE, GSM-WCDMA-LTE
IoT support	NB-IoT in band, guard band (GB), standalone (SA)
TX frequency range	925–960 MHz
RX frequency range	880–915 MHz
DL filter bandwidth	35 MHz
UL filter bandwidth	35 MHz
iBW (instantaneous bandwidth)	35 MHz
oBW (occupied bandwidth)	35 MHz
Number of carriers per pipe	Up to 8
Supported bandwidths	1.4, 3, 5, 10 MHz
PIM cancellation	Yes

Interfaces

Figure 12 ARDA interfaces

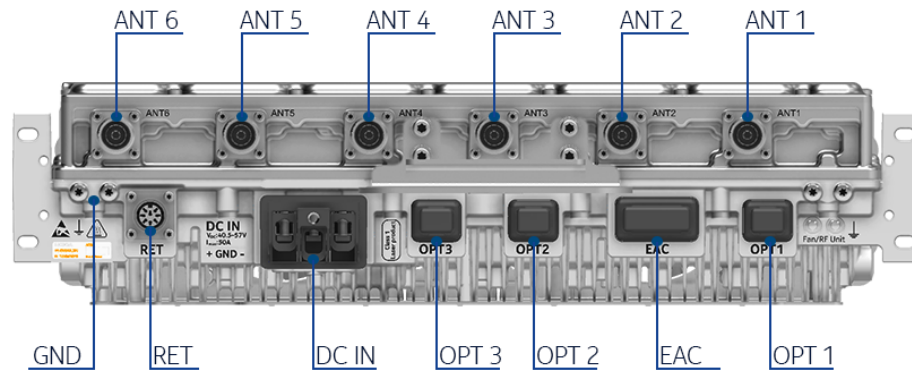



Table 45 ARDA interfaces

Interface	Label on the HW	Number of interfaces	Connector type	Additional info
Power Connector	DC IN	1	3-pole screw terminal	Allowed wire gauge: 10 mm ² to 35 mm ² (7 AWG to 2 AWG)
Antenna connector	ANT	6	4.3-10	EMHH required for straight connectors*
Remote Electrical Tilt	RET	1	8-pin circular	RS-485; EMHH required*
External Alarm Connection	EAC	1	MDR26	4 alarm inputs and 1 control output
Optical interface	OPT	3	SFP+	9.8 Gbit/s CPRI; Nokia IP seal
Grounding		1	2 x M5 screw	-

*EMHH Flexi 3U Casing and High Covers F&B (473187A) are required when connecting either 4.3-10 straight antenna cables or RET cables. For details, see *Flexi BTS Optional Items Description*.



WARNING! Risk of electric shock

Before turning RF power on, RF ports have to be terminated by nominal 50 Ω load (for example, feeder with antenna). However, if these conditions are not met, the plastic caps that are delivered within the unused RF ports should remain in place. The plastic caps isolate RF port from the environment, and thus provide electric shock security in case RF power is accidentally on.

Antenna Line Devices (ALDs) support

Table 46 ARDA ALD support

Property	Value
AISG	ANT1, ANT3, ANT5: AISG 2.0/3.0 ANT2, ANT4, ANT6: AISG 3.0 ping receiver RET: AISG 3.0
CWA (for non-AISG installations)	No
Voltage	ANT1, ANT3, ANT5, RET: 14.5 V DC
Power per port	30 W, 45 W total

Functional block diagram

Figure 13 ARDA functional block diagram

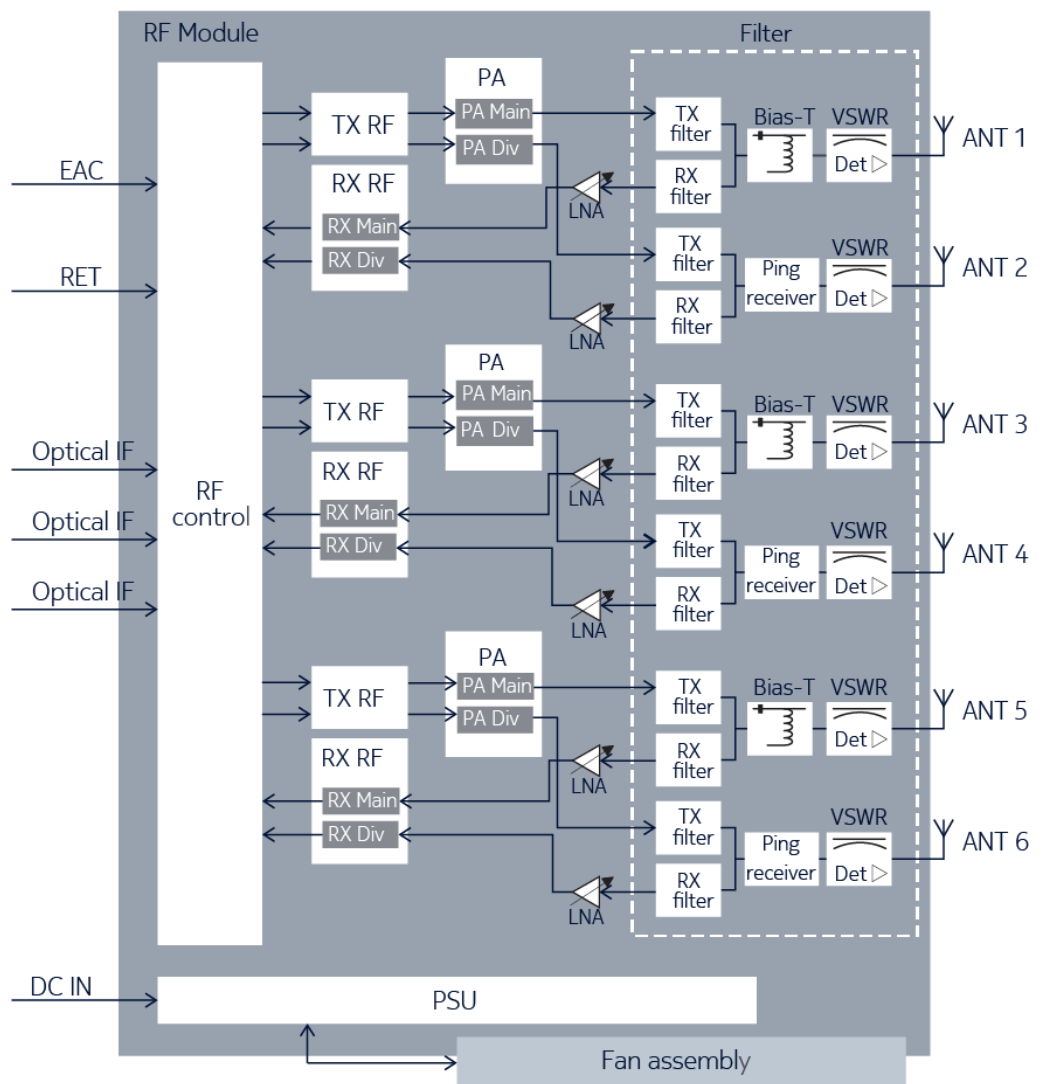

Electrical specifications

Table 47 ARDA electrical specifications

Property	Value
Nominal supply voltage	-48.0 V DC
Nominal input voltage range	-40.5 V DC to -57.0 V DC
Extended input voltage range	-36.0 V DC to -40.5 V DC -57.0 V DC to -60.0 V DC
Surge protection	Class II 5kA



Note: The minimum start-up voltage is -40.5 V DC. If the input voltage is below/beyond the extended limits, the unit might shut down.

Table 48 ARDA TX output power tolerance

Property	Value	Description
Typical power tolerance (nominal temperature)	± 0.8 dB	Over full TX RF bandwidth, nominal ambient temperature 25°C (77°F)
Typical power tolerance (extreme temperature)	± 2.0 dB	Over full TX RF bandwidth, extreme ambient temperature 55°C (131°F)

Power consumption

Typical power consumption [W] for 48VDC input, at 25°C, representative of typical product performance under the same conditions (HW variant, SW version, configuration, environment, and so on) with +/- 10% margin. Average = (6h low hour load, 10h medium hour load and 8h busy hour load) / 24h

Configurations explained on examples:

- GSM/WCDMA: 2/2/2 = three sectors, two carriers/TRXs per sector
- LTE:
 - o 2/2/2 2Tx = three sectors, two carriers per sector, 2Tx per carrier
 - o 1+1/1+1/1+1 4Tx = three dual-band sectors, one carrier per sector per band, 4Tx per carrier

Some radio units are capable of providing only one sector coverage. Then the power values in the table consider deployment of three radio units.

Table 49 ARDA power consumption in LTE mode

Configuration	Output Power per carrier (W)	Power consumption (W), ETSI 202706 average load P _{RRH, static}	Power consumption (W), ETSI 202706 busy hour load P _{BH RRH, static}	Power consumption (W), 100% RF power load P _{100% RRH}
1/1/1 2Tx	2x80	745	955	1468
1/1/1 2Tx	2x60	667	828	1210
1/1/1 2Tx	2x40	555	664	898
1/1/1 2Tx	2x30	514	603	782

Table 49 ARDA power consumption in LTE mode (Cont.)

Configuration	Output Power per carrier (W)	Power consumption (W), ETSI 202706 average load $P_{RRH, static}$	Power consumption (W), ETSI 202706 busy hour load $P_{BH RRH, static}$	Power consumption (W), 100% RF power load $P_{100\% RRH}$
1/1/1 2Tx	2x20	448	511	630

Power reduction

Table 50 Recommended ARDA power reduction in 256 QAM mode

Rated power [W]	Single carrier [dB]	Dual carrier [dB]
80	0.6	1.2
≤60	0	0.6



Note: The maximum power reduction (`dlCellPwrRed`) value is 20 dB. High power reduction values may cause radio outages.

Related optional items

- AMFN AirScale 2 Casing Adapter RRH 300 (474664A)
- ASAA AirScale 2 MDR26-open EAC cable 5 m (474288A)
- EMHA Flexi 3U Mounting Cover (470316A)
- EMHH Flexi 3U High Mounting Cover (473187A)
- FMAA Flexi Mounting Auxiliary Bracket (471657A)
- FMFA Flexi Mounting Kit for Floor, Wall and Pole (470149A)
- FMHA Flexi Side Covers (471524A)
- FPKA Flexi Pole Mounting Kit (30-120 mm) (471649A)
- AMRM AirScale one clip kit for RF modules (475018A)
- AMRC AirScale one clip rail 600 mm (474583A)
- FPKC Flexi Pole Mounting Kit (60-300 mm) (472821A)
- FSEP Flexi System External OVP (473246A)
- FSES Flexi System External OVP (472285A)

Installation options

- Pole (horizontal, vertical)
- Wall (horizontal, vertical)
- Stack
- Inside cabinet
- One-clip rail installation

Dimensions and weight

Table 51 ARDA dimensions and weight

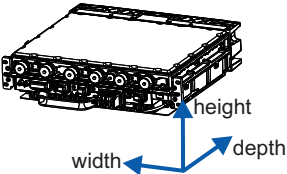
Property	Value	Dimensions orientation
Height	118 mm (4.65 in.)	
Width	441 mm (17.36 in.)	
Depth	402 mm (15.83 in.)	
Weight	23 kg (50.7 lb)	

Environmental specifications

Table 52 ARDA environmental specifications

Property	Value
Maximum operational outdoor temperature (in the shade)	55°C (131°F)
Maximum operational outdoor temperature (in the sun)	55°C (131°F)
Maximum indoor temperature	55°C (131°F)
Minimum operational temperature	-35°C (-31°F)
IP rating	IP65

SR002665 feature interdependencies

The SR002665: AirScale RFM 6T6R B8 480W ARDA feature is impacted by the following features:

- LTE:
 - LTE114: Cell Bandwidth - 10 MHz needs to be enabled to use LTE 10 MHz carriers.
 - LTE115: Cell Bandwidth - 5 MHz needs to be enabled to use LTE 5 MHz carriers.
 - LTE116: Cell Bandwidth - 3 MHz needs to be enabled to use LTE 3 MHz carriers.
 - LTE117: Cell Bandwidth - 1.4 MHz needs to be enabled to use LTE 1.4 MHz carriers.
 - With LTE614: Distributed Site, ARDA can be used in distributed sites with up to 23 km fiber length to the system module.
 - LTE1103: Load based Power Saving for multi-layer networks needs to be enabled to use Load based Power Saving for multi-layer networks.
 - LTE1203: Load based Power Saving with Tx path switching off needs to be enabled to use Load based Power Saving with Tx path switching off.
 - LTE2428: Nokia CPRI in FDD-LTE provides support for CPRI interface.
 - LTE2508: BTS Embedded Power Meter for Energy Efficiency Monitoring needs to be enabled to use BTS Embedded Power Meter for Energy Efficiency Monitoring.
 - LTE2541: Nokia CPRI RRH/RFM chaining

- provides support for chaining.
 - *LTE3036: Micro DTX extension*
needs to be enabled to use Micro DTX extension.
- SRAN:
 - With *SR000635: Radio Module Remote Reset*, malfunctioning or not responding ARCA module can be reset remotely.

5.1.6 Nokia AirScale RFM 6T6R B8 480 W (ARDB)

ARDB is introduced by SR002531: Nokia AirScale RFM 6T6R B8 480 W (ARDB)

Functional description

Table 53 ARDB functional specification

Property	Value
Output power	6x80 W
QAM	256 QAM (DL) 64 QAM (UL)
Number of TXRX	6T6R
Outdoor installation	Yes
Supported technologies (standalone and MSR)	GSM, WCDMA, FDD-LTE, 5G-ready GSM-WCDMA, WCDMA-LTE, GSM-LTE, GSM-WCDMA-LTE
IoT support	NB-IoT in band, guard band (GB), standalone (SA)
TX frequency range	935 – 960 MHz
RX frequency range	890 – 915 MHz
DL filter bandwidth	25 MHz
UL filter bandwidth	25 MHz
iBW (instantaneous bandwidth)	25 MHz
oBW (occupied bandwidth)	25 MHz
Supported bandwidths	1.4, 3, 5, 10 MHz
PIM cancellation	Yes

Interfaces

Figure 14 ARDB interfaces

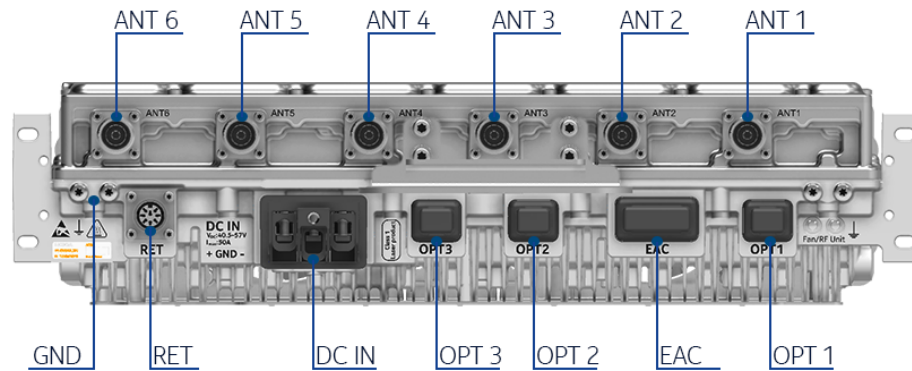



Table 54 ARDB interfaces

Interface	Label on the HW	Number of interfaces	Connector type	Additional info
Power Connector	DC IN	1	3-pole screw terminal	Allowed wire gauge: 10 mm ² to 35 mm ² (7 AWG to 2 AWG)
Antenna connector	ANT	6	4.3-10	EMHH required for straight connectors*
Remote Electrical Tilt	RET	1	8-pin circular	RS-485; EMHH required*
External Alarm Connection	EAC	1	MDR26	4 alarm inputs and 1 control output
Optical interface	OPT	3	SFP+	9.8Gbit/s CPRI; Nokia IP seal
Grounding		1	2 x M5 screw	-

*EMHH Flexi 3U Casing and High Covers F&B (473187A) are required when connecting either 4.3-10 straight antenna cables or RET cables. For details, see *Flexi BTS Optional Items Description*.



WARNING! Risk of electric shock

Before turning RF power on, RF ports have to be terminated by nominal 50 Ω load (for example, feeder with antenna). However, if these conditions are not met, the plastic caps that are delivered within the unused RF ports should remain in place. The plastic caps isolate RF port from the environment, and thus provide electric shock security in case RF power is accidentally on.

Antenna Line Devices (ALDs) support

Table 55 ARDB ALD support

ALD support	Value
AISG	ANT1, ANT3, ANT5: AISG 2.0/3.0 ANT2, ANT4, ANT6: AISG 3.0 ping receiver RET: AISG 3.0
Voltage	ANT1, ANT3, ANT5, RET: 14.5 V DC
Power per port	30 W, 45 W total

Functional block diagram

Figure 15 ARDB functional block diagram

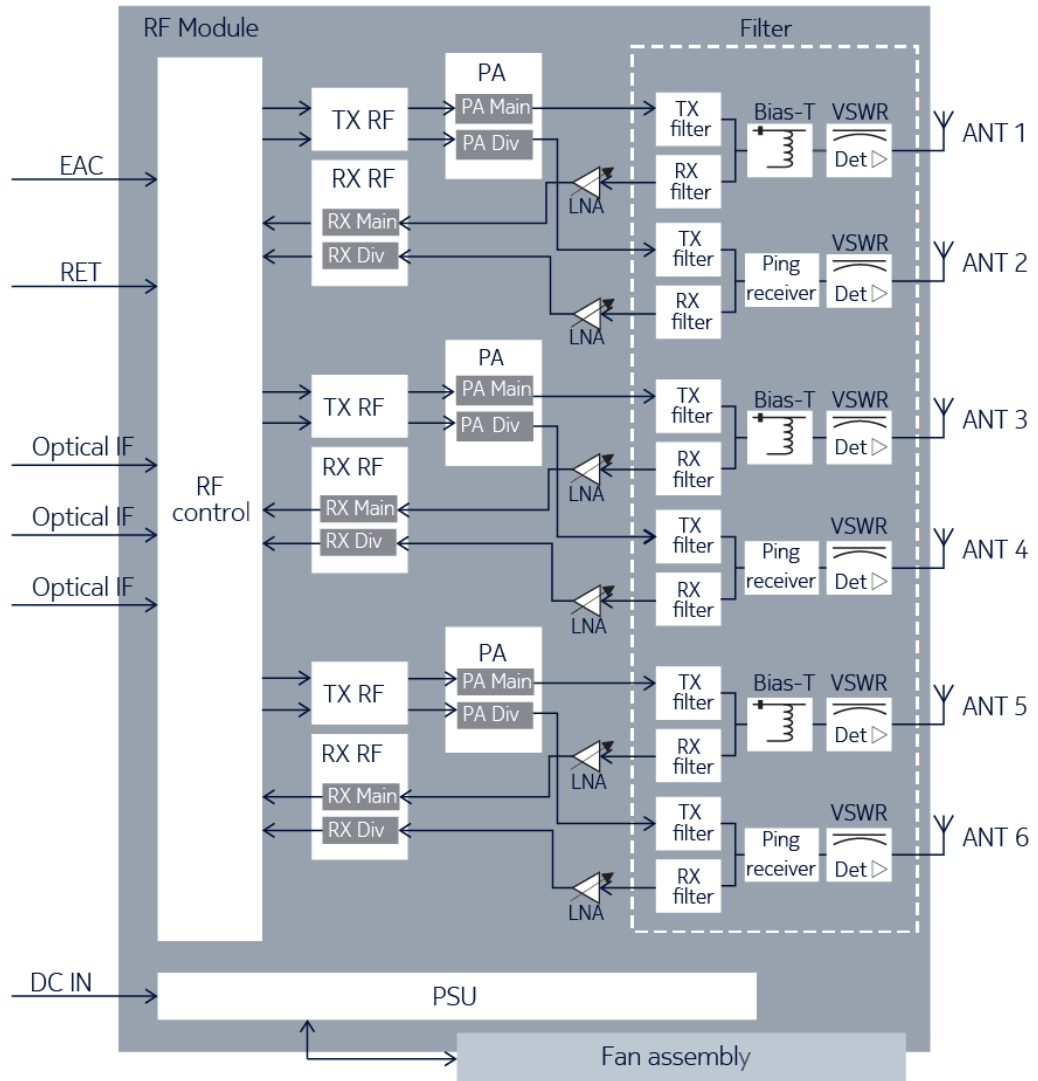

Electrical specifications

Table 56 ARDB electrical specifications

Property	Value
Nominal supply voltage	-48.0 V DC
Nominal input voltage range	-40.5 V DC to -57.0 V DC
Extended input voltage range	-36.0 V DC to -40.5 V DC -57.0 V DC to -60.0 V DC
Surge protection	Class II 5kA



Note: The minimum start-up voltage is -40.5 V DC. If the input voltage is below/beyond the extended limits, the unit might shut down.

Table 57 ARDB TX output power tolerance

Property	Value	Description
Typical power tolerance (nominal temperature)	± 0.8 dB	Over full TX RF bandwidth, nominal ambient temperature 25°C (77°F)
Typical power tolerance (extreme temperature)	± 2.0 dB	Over full TX RF bandwidth, extreme ambient temperature 55°C (131°F)

Power consumption

Typical power consumption [W] for 48VDC input, at 25°C, representative of typical product performance under the same conditions (HW variant, SW version, configuration, environment, and so on) with +/- 10% margin. Average = (6h low hour load, 10h medium hour load and 8h busy hour load) / 24h

Configurations explained on examples:

- GSM/WCDMA: 2/2/2 = three sectors, two carriers/TRXs per sector
- LTE:
 - o 2/2/2 2Tx = three sectors, two carriers per sector, 2Tx per carrier
 - o 1+1/1+1/1+1 4Tx = three dual-band sectors, one carrier per sector per band, 4Tx per carrier

Some radio units are capable of providing only one sector coverage. Then the power values in the table consider deployment of three radio units.

Table 58 ARDB power consumption in LTE mode

Configuration	Output Power per carrier (W)	Power consumption (W), ETSI 202706 average load $P_{RRH, static}$	Power consumption (W), ETSI 202706 busy hour load $P_{BH, RRH, static}$	Power consumption (W), 100% RF power load $P_{100\% RRH}$
1/1/1 2TX	2x80	748	959	1485
1/1/1 2TX	2x60	669	832	1222
1/1/1 2TX	2x40	558	670	906
1/1/1 2TX	2x30	517	608	787
1/1/1 2TX	2x20	450	514	634

Power reduction

Table 59 Recommended ARDB power reduction in 256 QAM mode

Rated power [W]	Single carrier [dB]	Dual carrier [dB]
80	0.6	1.2
≤60	0	0.6



Note: The maximum power reduction (dlCellPwrRed) value is 20 dB. High power reduction values may cause radio outages.

Related optional items

- AMFN AirScale 2 Casing Adapter RRH 300 (474664A)
- ASAA AirScale 2 MDR26-open EAC cable 5 m (474288A)
- EMHA Flexi 3U Mounting Cover (470316A)
- EMHH Flexi 3U High Mounting Cover (473187A)
- FMAA Flexi Mounting Auxiliary Bracket (471657A)
- FMFA Flexi Mounting Kit for Floor, Wall and Pole (470149A)
- FMHA Flexi Side Covers (471524A)
- FPKA Flexi Pole Mounting Kit (30-120 mm) (471649A)
- AMRM AirScale one clip kit for RF modules (475018A)
- AMRC AirScale one clip rail 600 mm (474583A)
- FPKC Flexi Pole Mounting Kit (60-300 mm) (472821A)
- FSEP Flexi System External OVP (473246A)
- FSES Flexi System External OVP (472285A)

Installation options

- Pole (horizontal, vertical)
- Wall (horizontal, vertical)
- Stack
- Inside cabinet
- One-clip rail installation

Dimensions and weight

Table 60 ARDB dimensions and weight

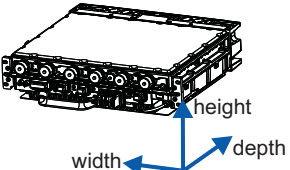
Property	Value	Dimensions orientation
Height	118 mm (4.65 in.)	
Depth	402 mm (15.83 in.)	
Width	441 mm (17.36 in.)	
Weight	23 kg (50.7 lb)	

Environmental specifications

Table 61 ARDB environmental specifications

Property	Value
Maximum operational outdoor temperature (in the shade)	55°C (131°F)
Maximum operational outdoor temperature (in the sun)	55°C (131°F)
Maximum indoor temperature	55°C (113°F)
Minimum operational temperature	-40°C (-40°F)
IP rating	IP65

SR002531 feature interdependencies

The SR002531: *Nokia AirScale RFM 6T6R B1 480 W (ARDB)* feature is impacted by the following features:

- *LTE114: Cell Bandwidth - 10 MHz*
Needs to be enabled to use LTE 10 MHz carriers.
- *LTE115: Cell Bandwidth - 5 MHz*
Needs to be enabled to use LTE 5 MHz carriers.
- With *LTE614: Distributed Site*,
ARDB can be used in distributed sites with up to 23 km fiber length to the system module.
- *LTE1103: Load based Power Saving for multi-layer networks*
Needs to be enabled to use Load based Power Saving for multi-layer networks.
- *LTE1203: Load based Power Saving with Tx path switching off*
Needs to be enabled to use Load based Power Saving with Tx path switching off.
- *LTE2428: Nokia CPRI in FDD-LTE*
Provides support for CPRI interface.
- *LTE2508: BTS Embedded Power Meter for Energy Efficiency Monitoring*
Needs to be enabled to use BTS Embedded Power Meter for Energy Efficiency Monitoring.
- *LTE2541: Nokia CPRI RRH/RFM chaining*
Provides support for chaining.
- *LTE3036: Micro DTX extension*
Needs to be enabled to use Micro DTX extension.
- *LTE3037: Power Saving - Slow Drain Voltage Modulation*
Needs to be enabled to use Load based PA efficiency improvement.

5.1.7 Nokia AirScale RFM 6T6R B20 360 W (ARMA)

ARMA is introduced by LTE5070: AirScale RFM 6T6R B20 360 W (ARMA).

Functional description

Table 62 ARMA functional specification

Property	Value
Output power	6x60 W
QAM	256 QAM (DL) 64 QAM (UL)
Number of TXRX	6T6R
Outdoor installation	Yes
Supported technologies (standalone and MSR)	FDD-LTE, 5G-ready
IoT support	NB-IoT in band, guard band (GB), standalone (SA)
TX frequency range	791 - 821 MHz
RX frequency range	832 - 862 MHz
DL filter bandwidth	30 MHz
UL filter bandwidth	30 MHz
iBW (instantaneous bandwidth)	30 MHz

Table 62 ARMA functional specification (Cont.)

Property	Value
oBW (occupied bandwidth)	30 MHz
Supported bandwidths	5, 10, 15, 20 MHz
PIM cancellation	Yes

Interfaces

Figure 16 ARMA interfaces

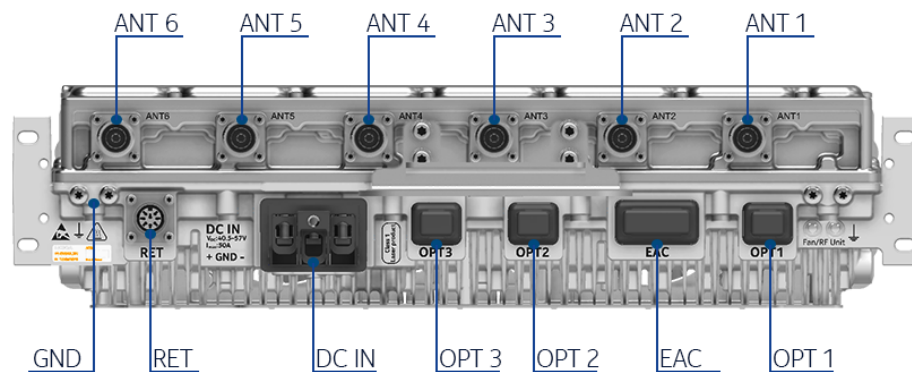



Table 63 ARMA interfaces

Interface	Label on the HW	Number of interfaces	Connector type	Additional info
Power Connector	DC IN	1	3-pole screw terminal	Allowed wire gauge: 10 mm ² to 35 mm ² (7 AWG to 2 AWG)
Antenna connector	ANT	6	4.3-10	EMHH required for straight cables*
Remote Electrical Tilt	RET	1	8-pin circular	RS-485; EMHH required*
External Alarm Connection	EAC	1	MDR26	4 alarm inputs and 1 control output

Table 63 ARMA interfaces (Cont.)

Interface	Label on the HW	Number of interfaces	Connector type	Additional info
Optical interface	OPT	3	SFP+	9.8 Gbit/s CPRI; Nokia IP seal
Grounding		1	2 x M5 screw	-

*EMHH Flexi 3U Casing and High Covers F&B (473187A) are required when connecting either 4.3-10 straight antenna cables or RET cables. For details, see *Flexi BTS Optional Items Description*.



WARNING! Risk of electric shock

Before turning RF power on, RF ports have to be terminated by nominal 50 Ω load (for example, feeder with antenna). However, if these conditions are not met, the plastic caps that are delivered within the unused RF ports should remain in place. The plastic caps isolate RF port from the environment, and thus provide electric shock security in case RF power is accidentally on.

Antenna Line Devices (ALDs) support

Table 64 ARMA ALD support

ALD support	Value
AISG	ANT1, ANT3, ANT5: AISG 2.0/3.0 ANT2, ANT4, ANT6: AISG 3.0 ping receiver RET: AISG 3.0
Voltage	ANT1, ANT3, ANT5, RET: 14.5 V DC
Power per port	30 W, 45 W total

Functional block diagram

Figure 17 ARMA functional block diagram

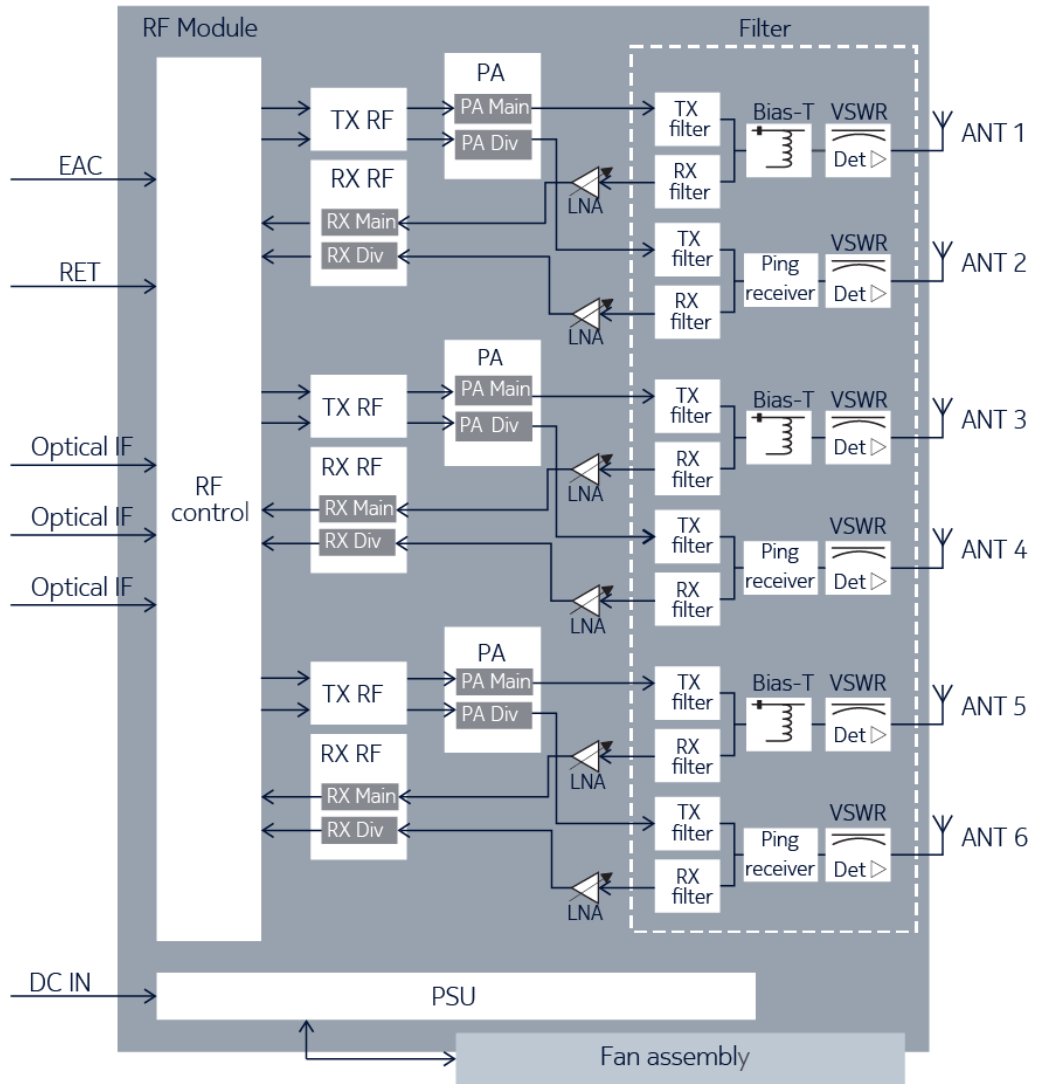

Electrical specifications

Table 65 ARMA electrical specifications

Property	Value
Nominal supply voltage	-48.0 V DC
Nominal input voltage range	-40.5 V DC to -57.0 V DC
Extended input voltage range	-36.0 V DC to -40.5 V DC -57.0 V DC to -60.0 V DC



Note: The minimum start-up voltage is -40.5 V DC. If the input voltage is below/beyond the extended limits, the unit might shut down.

Table 66 ARMA TX output power tolerance

Property	Value	Description
Typical power tolerance (nominal temperature)	± 0.8 dB	Over full TX RF bandwidth, nominal ambient temperature 25°C (77°F)
Typical power tolerance (extreme temperature)	± 2.0 dB	Over full TX RF bandwidth, extreme ambient temperature 55°C (131°F)

Power consumption



Note: ARMA power consumption will be provided in future releases.

Power reduction

Table 67 Recommended ARMA power reduction in 256 QAM mode

Rated power [W]	Single carrier [dB]	Dual carrier [dB]
60	0	0.6



Note: The maximum power reduction (`dlCellPwrRed`) value is 20 dB. High power reduction values may cause radio outages.

Related optional items

- AMFN AirScale 2 Casing Adapter RRH 300 (474664A)
- ASAA AirScale 2 MDR26-open EAC cable 5 m (474288A)
- EMHA Flexi 3U Mounting Cover (470316A)
- EMHH Flexi 3U High Mounting Cover (473187A)
- FMAA Flexi Mounting Auxiliary Bracket (471657A)
- FMFA Flexi Mounting Kit for Floor, Wall and Pole (470149A)
- FMHA Flexi Side Covers (471524A)
- FPKA Flexi Pole Mounting Kit (30-120 mm) (471649A)
- AMRM AirScale one clip kit for RF modules (475018A)
- AMRC AirScale one clip rail 600 mm (474583A)
- FPKC Flexi Pole Mounting Kit (60-300 mm) (472821A)
- FSEP Flexi System External OVP (473246A)
- FSES Flexi System External OVP (472285A)

Installation options

- Pole (vertical)
- Wall (vertical)
- Stack
- Inside a cabinet
- One-clip rail installation

Dimensions and weight

Table 68 ARMA dimensions and weight

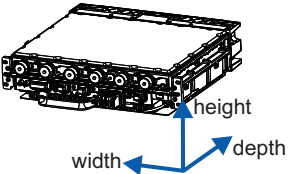
Property	Value	Dimensions orientation
Height	118 mm (4.65 in.)	
Depth	402 mm (15.83 in.)	
Width	441 mm (17.36 in.)	
Weight	23 kg (50.7 lb)	

Environmental specifications

Table 69 ARMA environmental specifications

Property	Value
Maximum operational outdoor temperature (in the shade)	55°C (131°F)
Maximum operational outdoor temperature (in the sun)	55°C (131°F)
Maximum indoor temperature	55°C (113°F)
Minimum operational temperature	-40°C (-40°F)
IP rating	IP65

LTE5070 feature interdependencies

The *LTE5070: Nokia AirScale RFM 6T6R B20 360 W (ARMA)* feature is impacted by the following features:

- *LTE112: Cell Bandwidth - 20 MHz*
Needs to be enabled to use LTE 20 MHz carriers.
- *LTE113: Cell Bandwidth - 15 MHz*
Needs to be enabled to use LTE 15 MHz carriers.
- *LTE114: Cell Bandwidth - 10 MHz*
Needs to be enabled to use LTE 10 MHz carriers.
- *LTE115: Cell Bandwidth - 5 MHz*
Needs to be enabled to use LTE 5 MHz carriers.
- With *LTE614: Distributed Site*,
ARMA can be used in distributed sites with up to 23 km (14.51 mi) fiber length to the system module.
- *LTE1103: Load based Power Saving for multi-layer networks*
Needs to be enabled to use Load based Power Saving for multi-layer networks.
- *LTE1203: Load based Power Saving with Tx path switching off*
Needs to be enabled to use Load based Power Saving with Tx path switching off.
- *LTE2508: BTS Embedded Power Meter for Energy Efficiency Monitoring*
Needs to be enabled to use BTS Embedded Power Meter for Energy Efficiency Monitoring.
- *LTE3036: Micro DTX extension*
Needs to be enabled to use Micro DTX extension.
- *LTE4787: Nokia 6Tx CPRI radio basic configurations with FSMF*
Defines configurations with FSMF.

- *LTE4760: Nokia 6TX CPRI radio configuration with AirScale SM*
Defines configurations with AirScale SM.

5.1.8 Nokia AirScale RFM 6T6R B28/n28 360 W (ARPA)

ARPA is introduced by LTE4663/5GC002227: AirScale RFM 6T6R B28/n28 360 W (ARPA).

Functional description

Table 70 ARPA functional specification

Property	Value
Output power	6x60 W
QAM	256 QAM (DL) 64 QAM (UL)
Number of TXRX	6T6R
Outdoor installation	Yes
Supported technologies (standalone and MSR)	FDD-LTE, 5G
IoT support	NB-IoT in band, guard band (GB), standalone (SA)
TX frequency range	758 - 788 MHz
RX frequency range	703 - 733 MHz
DL filter bandwidth	30 MHz
UL filter bandwidth	30 MHz
iBW (instantaneous bandwidth)	30 MHz
oBW (occupied bandwidth)	30 MHz
Number of carriers per pipe	Up to 8 carriers in total for all supported RATs
Supported bandwidths	LTE: 3, 5, 10, 15, 20 MHz 5G: 5, 10, 15, 20 MHz
PIM cancellation	Yes

Interfaces

Figure 18 ARPA interfaces

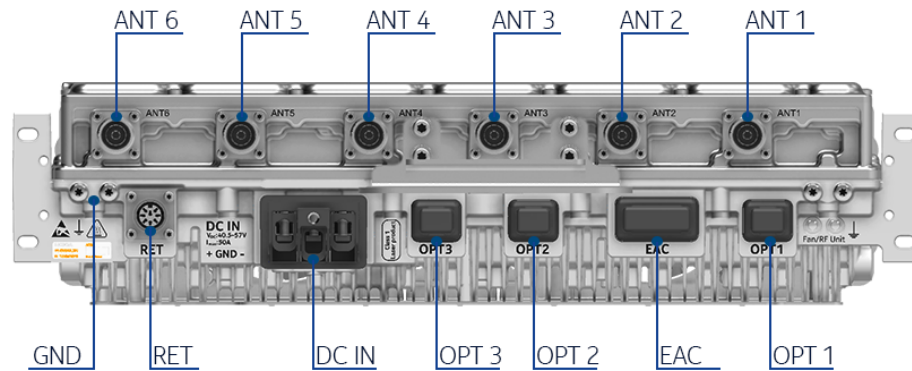



Table 71 ARPA interfaces

Interface	Label on the HW	Number of interfaces	Connector type	Additional info
Power Connector	DC IN	1	3-pole screw terminal	Allowed wire gauge: 10 mm ² to 35 mm ² (7 AWG to 2 AWG)
Antenna connector	ANT	6	4.3-10	EMHH required for straight cables*
Remote Electrical Tilt	RET	1	8-pin circular	RS-485; EMHH required*
External Alarm Connection	EAC	1	MDR26	4 alarm inputs and 1 control output
Optical interface	OPT	3	SFP+	9.8 Gbit/s CPRI; Nokia IP seal
Grounding		1	2 x M5 screw	-

*EMHH Flexi 3U Casing and High Covers F&B (473187A) are required when connecting either 4.3-10 straight antenna cables or RET cables. For details, see *Flexi BTS Optional Items Description*.



WARNING! Risk of electric shock

Before turning RF power on, RF ports have to be terminated by nominal 50 Ω load (for example, feeder with antenna). However, if these conditions are not met, the plastic caps that are delivered within the unused RF ports should remain in place. The plastic caps isolate RF port from the environment, and thus provide electric shock security in case RF power is accidentally on.

Antenna Line Devices (ALDs) support

Table 72 ARPA ALD support

ALD support	Value
AISG	ANT1, ANT3, ANT5: AISG 2.0/3.0 ANT2, ANT4, ANT6: AISG 3.0 ping receiver RET: AISG 3.0
Voltage	ANT1, ANT3, ANT5, RET: 14.5 V DC
Power per port	30 W, 45 W total

Functional block diagram

Figure 19 ARPA functional block diagram

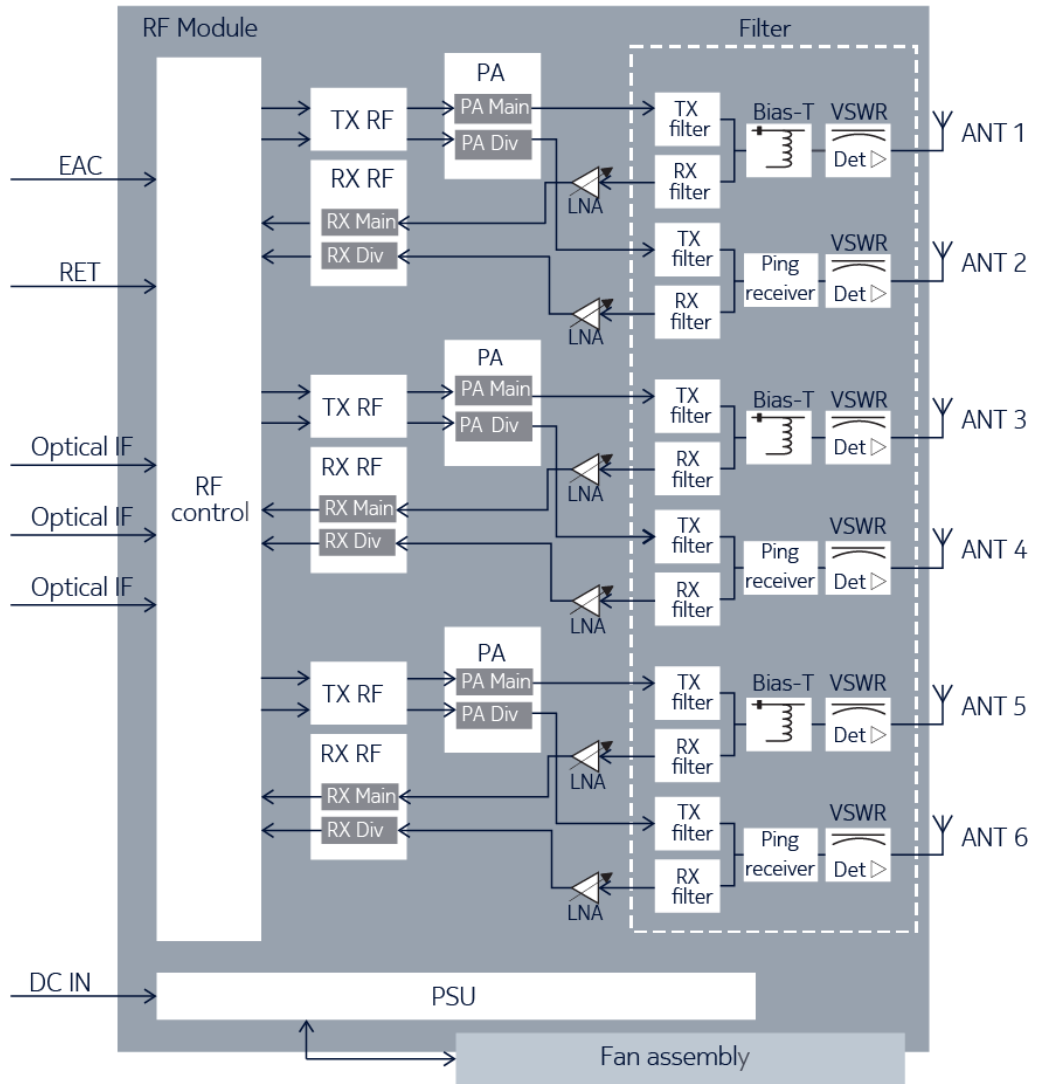

Electrical specifications

Table 73 ARPA electrical specifications

Property	Value
Nominal supply voltage	-48.0 V DC
Nominal input voltage range	-40.5 V DC to -57.0 V DC
Extended input voltage range	-36.0 V DC to -40.5 V DC -57.0 V DC to -60.0 V DC
Surge protection	Class II 5kA



Note: The minimum start-up voltage is -40.5 V DC. If the input voltage is below/beyond the extended limits, the unit might shut down.

Table 74 ARPA TX output power tolerance

Property	Value	Description
Typical power tolerance (nominal temperature)	± 0.8 dB	Over full TX RF bandwidth, nominal ambient temperature 25°C (77°F)
Typical power tolerance (extreme temperature)	± 2.0 dB	Over full TX RF bandwidth, extreme ambient temperature 55°C (131°F)

Power consumption



Note: ARPA power consumption will be provided in future releases.

Power reduction

Table 75 Recommended ARPA power reduction in 256 QAM mode

Rated power [W]	Single carrier [dB]	Dual carrier [dB]
60	0	0.6



Note: The maximum power reduction (`dlCellPwrRed`) value is 20 dB. High power reduction values may cause radio outages.

Related optional items

- AMFN AirScale 2 Casing Adapter RRH 300 (474664A)
- ASAA AirScale 2 MDR26-open EAC cable 5 m (474288A)
- EMHA Flexi 3U Mounting Cover (470316A)
- EMHH Flexi 3U High Mounting Cover (473187A)
- FMAA Flexi Mounting Auxiliary Bracket (471657A)
- FMFA Flexi Mounting Kit for Floor, Wall and Pole (470149A)
- FMHA Flexi Side Covers (471524A)
- FPKA Flexi Pole Mounting Kit (30-120 mm) (471649A)
- AMRM AirScale one clip kit for RF modules (475018A)
- AMRC AirScale one clip rail 600 mm (474583A)
- FPKC Flexi Pole Mounting Kit (60-300 mm) (472821A)
- FSEP Flexi System External OVP (473246A)
- FSES Flexi System External OVP (472285A)

Installation options

- Pole (vertical)
- Wall (vertical)
- Stack
- Inside a cabinet
- One-clip rail installation

Dimensions and weight

Table 76 ARPA dimensions and weight

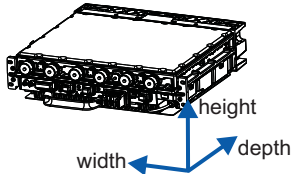
Property	Value	Dimensions orientation
Height	118 mm (4.65 in.)	
Depth	402 mm (15.83 in.)	
Width	441 mm (17.36 in.)	
Weight	23 kg (50.7 lb)	

Environmental specifications

Table 77 ARPA environmental specifications

Property	Value
Maximum operational outdoor temperature (in the shade)	55°C (131°F)
Maximum operational outdoor temperature (in the sun)	55°C (131°F)
Maximum indoor temperature	55°C (113°F)
Minimum operational temperature	-40°C (-40°F)
IP rating	IP65

LTE4663 feature interdependencies

The *LTE4663: Nokia AirScale RFM 6T6R B7 360 W (ARPA)* feature is impacted by the following features:

- *LTE112: Cell Bandwidth - 20 MHz*
Needs to be enabled to use LTE 20 MHz carriers.
- *LTE113: Cell Bandwidth - 15 MHz*
Needs to be enabled to use LTE 15 MHz carriers.
- *LTE114: Cell Bandwidth - 10 MHz*
Needs to be enabled to use LTE 10 MHz carriers.
- *LTE115: Cell Bandwidth - 5 MHz*
Needs to be enabled to use LTE 5 MHz carriers.
- *LTE116: Cell Bandwidth - 3 MHz*
Needs to be enabled to use LTE 3 MHz carriers.
- With *LTE614: Distributed Site*,
ARPA can be used in distributed sites with up to 23 km (14.51 mi) fiber length to the system module.
- *LTE1103: Load based Power Saving for multi-layer networks*
Needs to be enabled to use Load based Power Saving for multi-layer networks.
- *LTE1203: Load based Power Saving with Tx path switching off*
Needs to be enabled to use Load based Power Saving with Tx path switching off.
- *LTE2508: BTS Embedded Power Meter for Energy Efficiency Monitoring*
Needs to be enabled to use BTS Embedded Power Meter for Energy Efficiency Monitoring.
- *LTE2541: Nokia CPRI RRH/RFM chaining*
Provides support for chaining.

- *LTE3036: Micro DTX extension*
Needs to be enabled to use Micro DTX extension.
- *LTE4787: Nokia 6Tx CPRI radio basic configurations with FSMF*
Defines configurations with FSMF.
- *LTE4760: Nokia 6TX CPRI radio configuration with AirScale SM*
Defines configurations with AirScale SM.

5.2 Descriptions of single band Remote Radio Heads

5.2.1 Nokia AirScale RRH 2T B32/75 120 W (AHSA)

AHSA is introduced by LTE5048: Nokia AirScale RRH 2T B32/75 120 W AHSA.

Functional description

Table 78 AHSA functional specification

Property	Value
Output power	B32 and B75: 2x60 W
QAM	256 QAM (DL)
Number of TXRX	2T
Outdoor installation	Yes
Supported technologies (standalone and MSR)	FDD-LTE, 5G-ready
TX frequency range	B32: 1452 - 1496 MHz B75: 1432 - 1517 MHz
DL filter bandwidth	85 MHz
iBW (instantaneous bandwidth)	B32: 44 MHz B75: 85 MHz
oBW (occupied bandwidth)	80 MHz
Number of carriers per pipe	Up to 6
Supported bandwidths	5, 10, 15, 20 MHz
PIM cancellation	Not applicable

Interfaces

Figure 20 AHSA interfaces

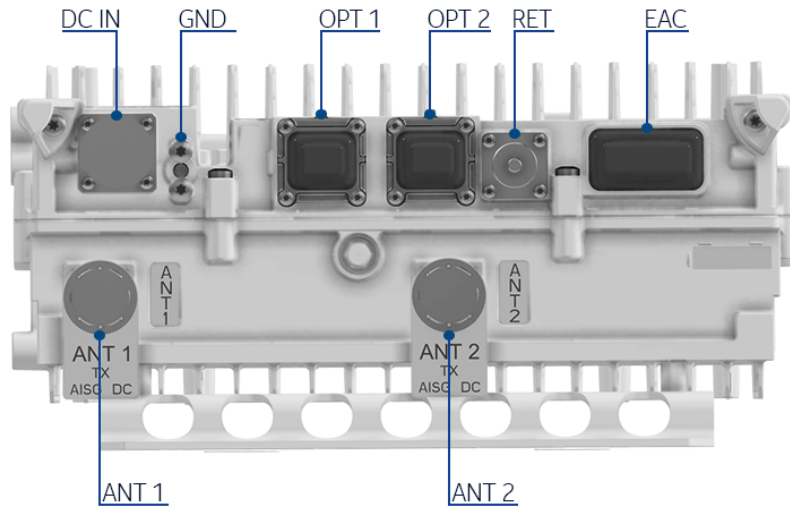



Table 79 AHSA interfaces

Interface	Label on the HW	Number of interfaces	Connector type	Additional info
Power Connector	DC IN	1	Low power circular	APPA, APPB, APPC
Antenna connector	ANT	4	4.3-10	-
Remote Electrical Tilt	RET	1	8-pin circular	RS-485
Optical interface	OPT	2	SFP	9.8 Gbps, CPRI, Nokia IP seal
External Alarm Connection	EAC	1	MDR-26	4 alarm inputs and 1 control output
Grounding		1	M8 or dual M5 screws	-
Fan	FAN	1	Nokia fan	Located on the opposite side



WARNING! Risk of electric shock

Before turning RF power on, RF ports have to be terminated by nominal 50 Ω load (for example, feeder with antenna). However, if these conditions are not met, the plastic caps that are delivered within the unused RF ports should remain in place. The plastic caps isolate RF port from the environment, and thus provide electric shock security in case RF power is accidentally on.

Antenna Line Devices (ALDs) support

Table 80 AHSA ALD support

ALD support	Value
AISG	RET, ANT1, ANT2: AISG 2.0/3.0
Voltage	RET, ANT1, ANT2: 14.5 V
Power per port	30 W, 45 W total

Functional block diagram

Figure 21 AHSA functional block diagram

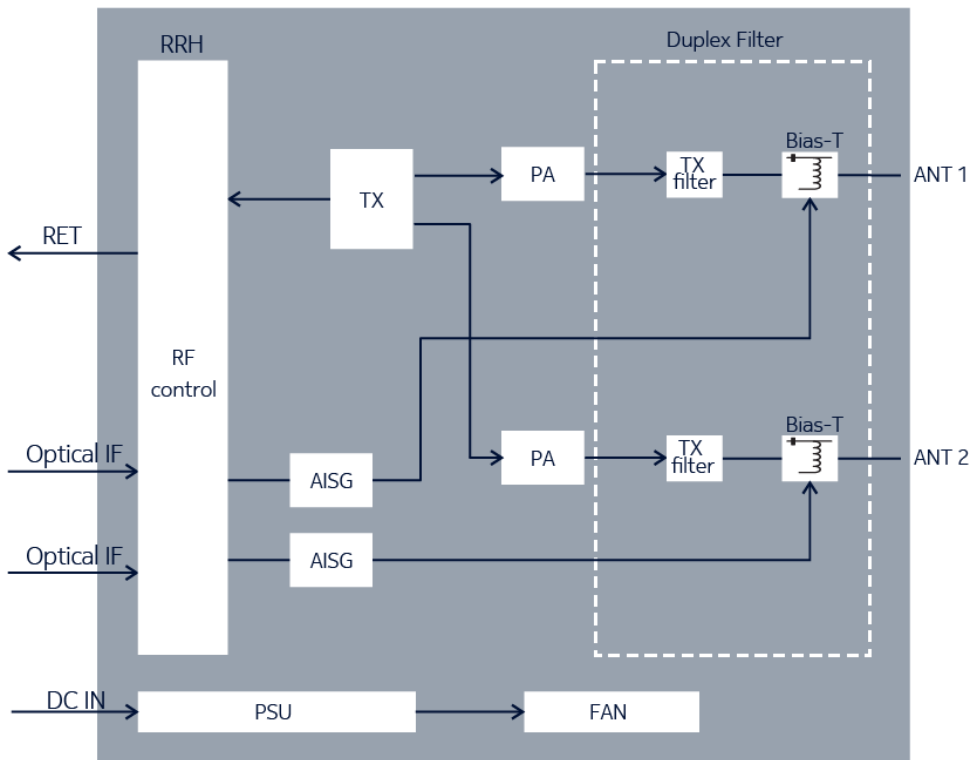

Electrical specifications

Table 81 AHSA electrical specifications

Property	Value
Nominal supply voltage	-48.0 V DC
Nominal input voltage range	-40.5 V DC to -57.0 V DC
Extended input voltage range	-36.0 V DC to -40.5 V DC -57.0 V DC to -60.0 V DC



Note: The minimum start-up voltage is -40.5 V DC. If the input voltage is below/beyond the extended limits, the unit might shut down.

Power consumption

Typical power consumption [W] for 48VDC input, at 25°C, representative of typical product performance under the same conditions (HW variant, SW version, configuration, environment, and so on) with +/- 10% margin. Average = (6h low hour load, 10h medium hour load and 8h busy hour load) / 24h

Configurations explained on examples:

- GSM/WCDMA: 2/2/2 = three sectors, two carriers/TRXs per sector
- LTE:
 - o 2/2/2 2Tx = three sectors, two carriers per sector, 2Tx per carrier
 - o 1+1/1+1/1+1 4Tx = three dual-band sectors, one carrier per sector per band, 4Tx per carrier

Some radio units are capable of providing only one sector coverage. Then the power values in the table consider deployment of three radio units.

Table 82 AHSA power consumption in LTE mode

Configuration	Output Power per carrier (W)	Power consumption (W), ETSI 202706 average load P _{RRH} , static	Power consumption (W), ETSI 202706 busy hour load P _{BH} , RRH, static	Power consumption (W), 100% RF power load P _{100% RRH}
1/1/1 2Tx	2x60	640	784	1137
1/1/1 2Tx	2x40	526	623	831
1/1/1 2Tx	2x30	460	533	689
1/1/1 2Tx	2x20	381	430	533

Power reduction



Note: The maximum power reduction (dlCellPwrRed) value is 20 dB. High power reduction values may cause radio outages.

Related optional items

- ASFA AirScale 2 fan unit 300 (473968A)
- APAA AirScale AC-DC Power Unit 760W (473936A)
- AMAA AirScale 2 casing for RRH aux-units (474141A):
 - APAC AirScale AC PDU 1 to 3 (474142A)
 - APAA AirScale AC-DC Power Unit 760W (473936A) - maximum three units per one AMAA
- AMGD AirScale 2 cover 300 x 126-150 (474270A)
- AMBF AirScale book mount kit 126-150 (474278A)
- FPKA Flexi Pole Mounting Kit (30-120 mm) (471649A)
- FPKC Flexi Pole Mounting Kit (60-300 mm) (472821A)
- AMPA Pole Mounting Kit (30-120 mm) (473879A)
- AMFA AirScale 2 FPKx fixing adapter (474289A)
- AMFC AirScale 2 19" rack fixing 300 (474291A)
- AMFN AirScale 2 casing adapter RRH 300 (474664A)
- AMRA AirScale one clip bracket 51-125 (474580A)
- AMRC AirScale one clip rail 600 mm (474583A)

- ASAA AirScale 2 MDR26-open EAC cable 5 m (474288A)
- APPA AirScale 2 26A DC plug 3.3-10 mm² (474281A)
- APPB AirScale 2 55A DC plug 3.3-10 mm² (474282A)
- APPC AirScale 2 55A DC plug 10-16 mm² (474283A)
- ACPA AirScale 2 Fiber Protection (474297A)

Installation options

- Pole: vertical, horizontal with an optional fan
- Wall: vertical, horizontal with an optional fan
- Book mounting
- One-clip rail mounting
- Inside a 19-inch rack (an adapter and a rack are required)



NOTICE: Install this RRH in a vertical orientation with connectors on the bottom side, to ensure convection cooling. For horizontal installation fans are required.

Dimensions and weight

Table 83 AHSA dimensions and weight

Property	Value	Dimensions orientation
Height	Core RRH: 336 mm (13.25 in.) With mounting brackets: 428 mm (16.87 in.)	
Width	309 mm (12.17 in.)	
Depth	Core RRH: 130 mm (5.12 in.) With mounting brackets: 153 mm (6.02 in.)	
Weight	12.0 kg (26.5 lb)	

Environmental specifications

Table 84 AHSA environmental specifications

Property	Value
Maximum operational outdoor temperature (in the shade)	55°C (131°F)
Maximum operational outdoor temperature (in the sun)	55°C (131°F)
Maximum indoor temperature	45°C (113°F)
Minimum operational temperature	-40°C (-40°F)
IP rating	IP65

LTE5048 feature interdependencies

The LTE5048: Nokia AirScale RRH 2T B32/75 120 W AHSA feature is impacted by the following features:

- *LTE112: Cell Bandwidth - 20 MHz* enables to use LTE 20 MHz carriers.
- *LTE113: Cell Bandwidth - 15 MHz* enables to use LTE 15 MHz carriers
- *LTE114: Cell Bandwidth - 10 MHz* enables to use LTE 10 MHz carriers
- *LTE115: Cell Bandwidth - 5 MHz* enables to use LTE 5 MHz carriers
- With *LTE614: Distributed Site*, AHSA can be used in distributed sites with up to 23 km (14.29 mi) fiber length to the system module.
- *LTE1103: Load based Power Saving for multi-layer networks* or *LTE1203: Load based Power Saving with Tx path switching off* need to be enabled to use PA shutdown feature.
- *LTE2508: BTS Embedded Power Meter for Energy Efficiency Monitoring* needs to be enabled to use energy metering feature.
- *LTE2541: Nokia CPRI RRH/RFM chaining* supports Nokia CPRI chain of up to four radio units.

5.2.2 Nokia AirScale RRH 2T2R B3 120 W (FHEL)

FHEL is introduced by LTE2680: Nokia AirScale RRH 2T2R B3 120W (FHEL).

Functional description

Table 85 FHEL functional specification

Property	Value
Output power	2x60 W
Number of TXRX	2T2R
Outdoor installation	Yes
Supported technologies (standalone and MSR)	GSM, FDD-LTE, 5G-ready
TX frequency range	1805-1880 MHz
RX frequency range	1710-1785 MHz
DL filter bandwidth	75 MHz
UL filter bandwidth	75 MHz
DL iBW (instantaneous bandwidth)	75 MHz 37.5 MHz in GSM
UL iBW (instantaneous bandwidth)	75 MHz
oBW (occupied bandwidth)	40 MHz
Supported bandwidths	1.4, 3, 5, 10, 15, 20 MHz

Interfaces

Figure 22 FHEL interfaces

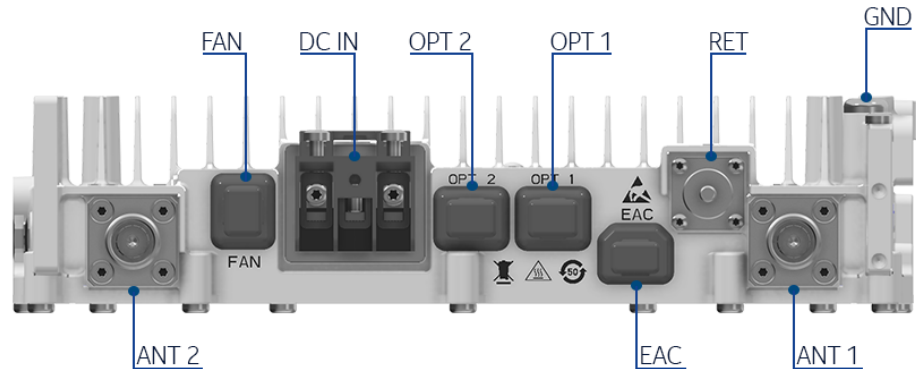

Table 86 FHEL interfaces

Interface	Label on the HW	Number of interfaces	Connector type	Additional info
Power Connector	DC IN	1	3-pole screw terminal	Allowed wire gauge: 3.3 mm ² to 35 mm ² (12 AWG to 2 AWG)
Antenna connector	ANT	2	4.3-10	-
Remote Electrical Tilt	RET	1	8-pin circular	RS-485
External Alarm Connection	EAC	1	USB 3.0 Type-A	4 alarm inputs and 1 control output
Optical interface	OPT	2	SFP+	6 Gbps, OBSAI, Nokia IP seal
Ground		1	M8 or dual M5 screws	-
Fan	Fan	1	2-pin Micro-Fit	-



WARNING! Risk of electric shock

Before turning RF power on, RF ports have to be terminated by nominal 50 Ω load (for example, feeder with antenna). However, if these conditions are not met, the plastic caps that are delivered within the unused RF ports should remain in place. The plastic caps isolate RF port from the environment, and thus provide electric shock security in case RF power is accidentally on.

Antenna Line Devices (ALDs) support

Table 87 FHEL ALD support

ALD support	Value
AISG	RET: AISG 2.0
CWA (for non-AISG installations)	No
Voltage	RET: 14.5 V
Power on RET port	30 W

Functional block diagram

Figure 23 FHEL functional block diagram

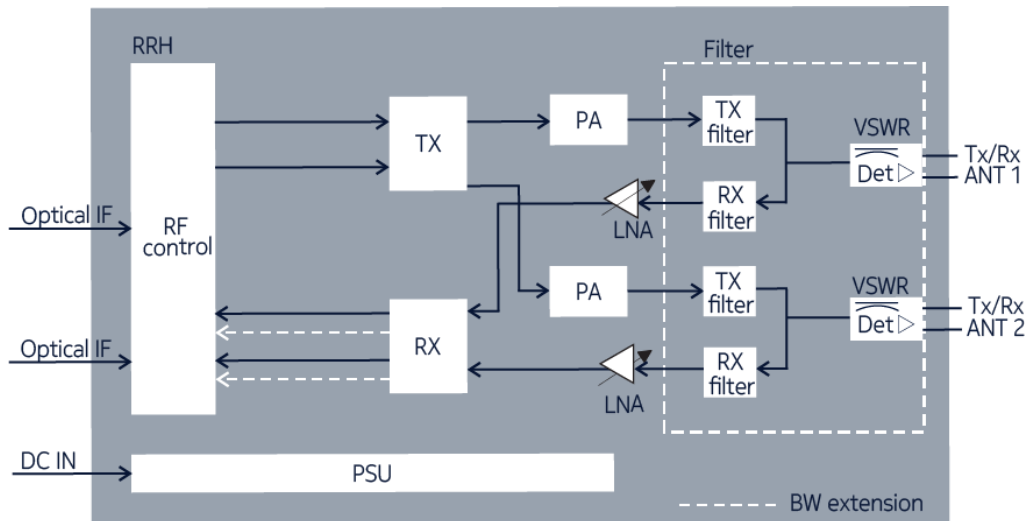

Electrical specifications

Table 88 FHEL electrical specifications

Property	Value
Nominal supply voltage	-48.0 V DC
Nominal input voltage range	-40.5 V DC to -57.0 V DC
Extended input voltage range	-36.0 V DC to -40.5 V DC -57.0 V DC to -60.0 V DC



Note: The minimum startup voltage is -40.5 V DC. If the input voltage is below/beyond extended limits, the unit might shut down.

Power consumption

Typical power consumption [W] for 48VDC input, at 25°C, representative of typical product performance under the same conditions (HW variant, SW version, configuration, environment, and so on) with +/- 10% margin. Average = (6h low hour load, 10h medium hour load and 8h busy hour load) / 24h

Configurations explained on examples:

- GSM/WCDMA: 2/2/2 = three sectors, two carriers/TRXs per sector
- LTE:
 - o 2/2/2 2Tx = three sectors, two carriers per sector, 2Tx per carrier
 - o 1+1/1+1/1+1 4Tx = three dual-band sectors, one carrier per sector per band, 4Tx per carrier

Some radio units are capable of providing only one sector coverage. Then the power values in the table consider deployment of three radio units.

Table 89 FHEL power consumption

Mode	Configuration	Output power per carrier [W]	Power consumption ETSI 202706 average load P_{RRH} , static	Power consumption ETSI 202706 busy hour load P_{BH} , RRH , static	Power consumption 100% RF power load $P_{100\% RRH}$	Power consumption Typical as 25% TCH load, 60% DTX, 4 dB PC	Power consumption Busy as 50% TCH load, 60% DTX, 4 dB PC	Power consumption Max load (2% GoS), 60% DTX, 4 dB PC
GSM	1/1/1	20	453	453	453	453	453	453
	2/2/2	20	469	489	570	459	463	467
	4/4/4	20	601	725	1015	582	664	694
LTE	1/1/1 2Tx	20+20	525	609	760	-	-	-
	1/1/1 2Tx	40+40	637	776	1050	-	-	-
	1/1/1 2Tx	60+60	742	938	1353	-	-	-
MSR	GSM 2/2/2 LTE 1/1/1 2Tx 10 MHz	20 20+20	669	754	968	-	-	-
	GSM 4/4/4 LTE 1/1/1 2Tx 10 MHz	15 20+20	699	821	1059	-	-	-

Power reduction

Table 90 FHEL power reduction in 256 QAM

Single carrier [dB]	Dual carrier [dB]
0.7	1



Note: The maximum power reduction (`dlCellPwrRed`) value is 20 dB. High power reduction values may cause radio outages.

Related optional items

- AMPA Pole Mounting Kit (30-120 mm)
- FMNC AirScale 1.0 Medium Fan Kit
- AMLA Flat mount adapter bracket
- FMNH AirScale Ladder Mount Kit
- FPKA/FPKC Flexi Pole Mounting Kit
- AMFQ AirScale RAS2 kit for RRH 600

Installation options

- wall installation
- pole installation
- flat mount without fans on wall or pole
- vertical book mount without fans
- horizontal book mount with fans
- inside the Radio Antenna System (RAS) without fans



NOTICE: Install this RRH in a vertical orientation with connectors on the bottom side, to ensure convection cooling. For horizontal installation fans are required.

Dimensions and weight

Table 91 FHEL dimensions and weight

Property	Value	Dimensions orientation
Height	Core RRH: 591.6 mm (23.3 in.) With cover, handle, and unit bracket: 600 mm (23.6 in.) With cover, handle, unit bracket, and fan kit: 630.2 mm (24.8 mm)	<p>Dimensions orientation in vertical mount with cover</p> <p>Dimensions orientation in horizontal mount with cover and fan</p>
Depth	Core RRH: 320 mm (12.6 in.) With cover, handle, and unit bracket: 424 mm (16.7 in.) With cover, handle, unit bracket, and fan kit: 424 mm (16.7 in.)	
Width	Core RRH: 77.5 mm (3 in.) With cover, handle, and unit bracket: 80 mm (3.1 in.) With cover, handle, unit bracket, and fan kit : 80 mm (3.1 in.) With cover, handle, unit bracket, and fan kit (unit bracket rotated 90 degrees for horizontal mounting) : 143 mm (5.6 in.)	
Weight	Core RRH: 12.5 kg (27.5 lb)	

Table 91 FHEL dimensions and weight (Cont.)

Property	Value	Dimensions orientation
	With cover, handle and unit mounting bracket: 14.4 kg (31.7 lb) With cover, handle, unit mounting bracket, and fan kit: 15.5 kg (34.2 lb)	
Volume	Core RRH: 12.5 l With cover, handle, and unit bracket: 20.3 l With cover, handle, unit bracket, and fan kit: 32 l	

Environmental specifications

Table 92 FHEL environmental specifications

Property	Value
Maximum operational outdoor temperature in the shade, assuming wind speed is 3 m/s (at constant high ambient temperature, maximum output power might be limited)	55°C (131°F)
Maximum operational outdoor temperature in the sun, assuming wind speed is 3 m/s (at constant high ambient temperature, maximum output power might be limited)	50°C (122°F)
Maximum indoor temperature, assuming wind speed is 0 m/s, valid for fanless products (at constant high ambient temperature, maximum output power might be limited)	40°C (104°F)
Minimum operational temperature (including cold start)	-40°C (-40°F)
IP rating	IP65

LTE2680 feature interdependencies

The *LTE2680: FHEL AirScale RRH 2T2R B3 120 W* feature is impacted by the following features:

- *LTE112: Cell Bandwidth - 20 MHz*
It enables LTE 20 MHz carriers.
- *LTE113: Cell Bandwidth - 15 MHz*
It enables LTE 15 MHz carriers.
- *LTE114: Cell Bandwidth - 10 MHz*
It enables LTE 10 MHz carriers.
- *LTE115: Cell Bandwidth - 5 MHz*
It enables LTE 5 MHz carriers.
- *LTE116: Cell Bandwidth - 3 MHz*

- It enables LTE 3 MHz carriers.
- *LTE117: Cell Bandwidth - 1.4 MHz*
It enables LTE 1.4 MHz carriers.
- *LTE614: Distributed Site*
With LTE614 FHEL can be used in distributed sites with up to 23 km fiber length to the system module.
- *LTE977: RF chaining*
With LTE977 FHEL supports chains of up to four radio units.
- *LTE2437: Supported RAS Installation options in FL16 Release*
With LTE2437 RAS installation options are defined.
- FHEL supports the following power saving features:
 - *LTE1103: Load based Power Saving for multi-layer networks*
 - *LTE1203: Load based Power Saving with Tx path switching off*
 - *LTE1891: eNode B power saving - Micro DTX*
 - *LTE2508: BTS Embedded Power Meter for Energy Efficiency Monitoring*

5.2.3 Nokia AirScale RRH 2T2R 900J 120 W (FHDI)

FHDI is introduced by LTE3516/SR001451: Nokia AirScale RRH 2T2R 900J 120 W (FHDI).

Functional description

Table 93 FHDI functional specification

Property	Value
Output power	2x60 W
QAM	256 QAM (DL) 64 QAM (UL)
Number of TXRX	2T2R
Outdoor installation	Yes
Supported technologies (standalone and MSR)	GSM, WCDMA, FDD-LTE, 5G-ready
TX frequency range	935 - 960 MHz
RX frequency range	890 - 915 MHz
DL filter bandwidth	25 MHz
UL filter bandwidth	25 MHz
iBW (instantaneous bandwidth)	25 MHz
oBW (occupied bandwidth)	25 MHz
Number of carriers per pipe	Up to 5
Supported bandwidths	1.4, 3, 5, 10 MHz

Interfaces

Figure 24 FHDI interfaces

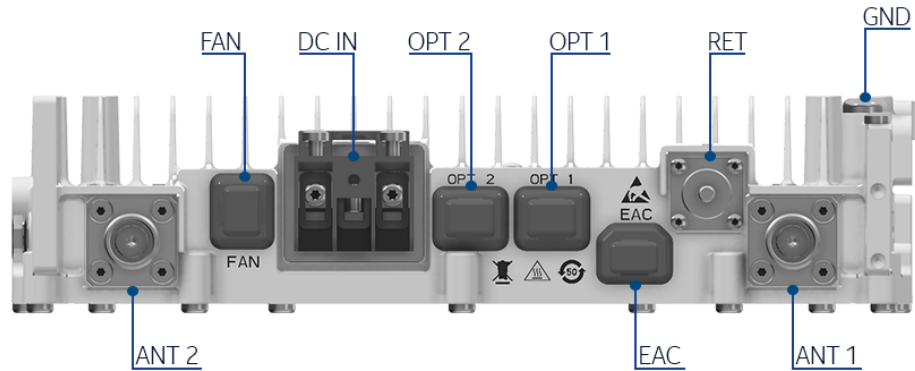



Table 94 FHDI interfaces

Interface	Label on the HW	Number of interfaces	Connector type	Additional info
Power Connector	DC IN	1	3-pole screw terminal	Allowed wire gauge: 3.3 mm ² to 35 mm ² (12 AWG to 2 AWG)
Antenna connector	ANT	2	4.3-10	-
Remote Electrical Tilt	RET	1	8-pin circular	RS-485
External Alarm Connection	EAC	1	USB 3.0 Type A	4 alarm inputs and 1 control output
Optical interface	OPT	2	SFP+	6 Gbps, OBSAI, Nokia IP seal
Grounding		1	M8 or dual M5 screws	-
Fan	Fan	1	2-pin Micro-Fit	-



WARNING! Risk of electric shock

Before turning RF power on, RF ports have to be terminated by nominal 50 Ω load (for example, feeder with antenna). However, if these conditions are not met, the plastic caps that are delivered within the unused RF ports should remain in place. The plastic caps isolate RF port from the environment, and thus provide electric shock security in case RF power is accidentally on.

Antenna Line Devices (ALDs) support

Table 95 FHDI ALD support

ALD support	Value
AISG	RET: AISG 2.0
CWA (for non-AISG installations)	No
Voltage	RET: 14.5 V
Power per port	30 W

Functional block diagram

Figure 25 FHDI functional block diagram

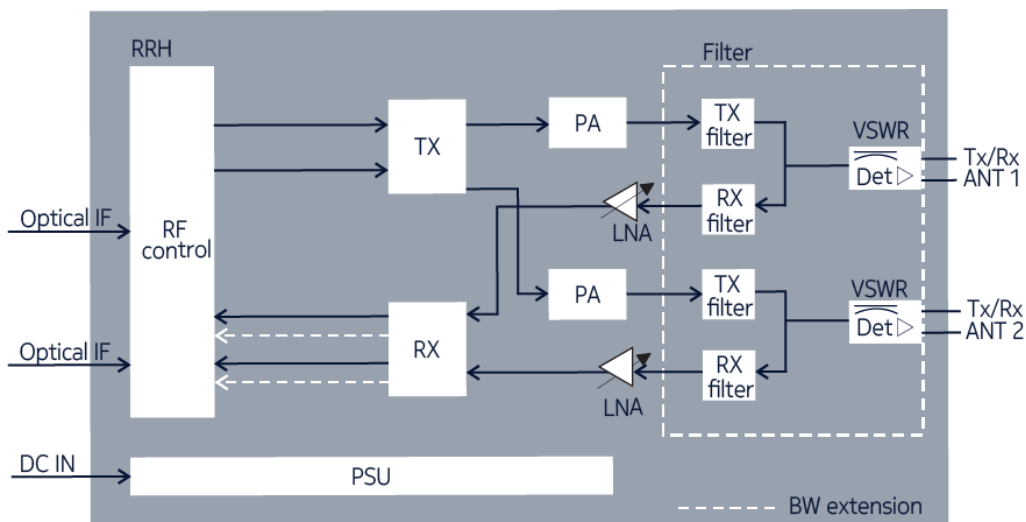

Electrical specifications

Table 96 FHDI electrical specifications

Property	Value
Nominal supply voltage	-48.0 V DC
Nominal input voltage range	-40.5 V DC to -57.0 V DC
Extended input voltage range	-36.0 V DC to -40.5 V DC -57.0 V DC to -60.0 V DC

i **Note:** The minimum startup voltage is -40.5 V DC. If the input voltage is below/beyond extended limits, the unit might shut down.

Power consumption

i **Note:** FHDI power consumption values will be provided in future releases.

Power reduction

i **Note:** The maximum power reduction (dlCellPwrRed) value is 20 dB. High power reduction values may cause radio outages.

Related optional items

- AMPA Pole Mounting Kit (30-120 mm)
- FMNC AirScale 1.0 Medium Fan Kit
- AMLA Flat mount adapter bracket
- FMNH AirScale Ladder Mount Kit
- FPKA/FPKC Flexi Pole Mounting Kit
- AMFQ AirScale RAS2 kit for RRH 600

Installation options

- wall installation
- pole installation
- flat mount without fans on wall or pole
- vertical book mount without fans
- horizontal book mount with fans
- inside the Radio Antenna System (RAS) without fans



NOTICE: Install this RRH in a vertical orientation with connectors on the bottom side, to ensure convection cooling. For horizontal installation fans are required.

Dimensions and weight

Table 97 FHDI dimensions and weight

Property	Value	Dimensions orientation
Height	Core RRH: 591.6 mm (23.3 in.) With cover, handle, and unit bracket: 600 mm (23.6 in.) With cover, handle, unit bracket, and fan kit: 630.2 mm (24.8 in.)	Dimensions orientation in vertical mount with cover 
Depth	320 mm (9.6 in.) With cover, handle, and unit bracket: 424 mm (16.7 in.) With cover, handle, unit bracket, and fan kit: 424 mm (16.7 in.)	Dimensions orientation in horizontal mount with cover and fan 
Width	Core RRH: 77.5 mm (3 in.) With cover, handle, and unit bracket: 80 mm (3.1 in.) With cover, handle, unit bracket, and fan kit : 80 mm (3.1 in.) With cover, handle, unit bracket, and fan kit (unit bracket rotated 90 degrees for horizontal mounting) : 143 mm (5.6 in.)	

Table 97 FHDl dimensions and weight (Cont.)

Property	Value	Dimensions orientation
Weight	Core RRH: 12.5 kg (27.5 lb) With cover, handle and unit mounting bracket: 14.4 kg (31.7 lb) With cover, handle, unit mounting bracket, and fan kit: 15.5 kg (34.2 lb)	
Volume	Core RRH: 12.5 l With cover, handle, and unit bracket: 20.3 l With cover, handle, unit bracket, and fan kit: 32 l	

Environmental specifications

Table 98 FHDl environmental specifications

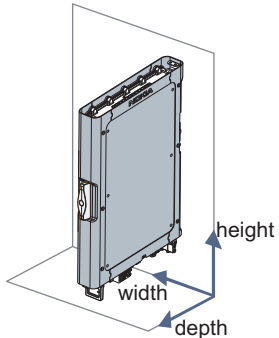
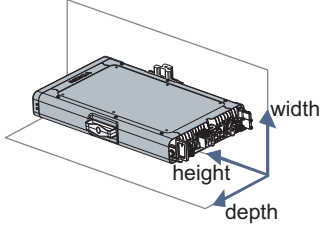
Property	Value
Maximum operational outdoor temperature in the shade, assuming wind speed is 3 m/s (at a constant high ambient temperature, maximum output power might be limited)	55°C (131°F)
Maximum operational outdoor temperature in the sun, assuming wind speed is 3 m/s (at a constant high ambient temperature, maximum output power might be limited)	50°C (122°F)
Maximum indoor temperature, assuming wind speed is 0 m/s, valid for fanless products (at a constant high ambient temperature, maximum output power might be limited)	40°C (104°F)
Minimum operational temperature (including cold start)	-40°C (-40°F)
IP rating	IP65

LTE3516 feature interdependencies

The *LTE3516: AirScale RRH 2T2R 900J 120 W FHDl* feature is impacted by the following features:

- *LTE114: Cell Bandwidth - 10 MHz*
Needs to be enabled to use LTE 10 MHz carriers.
- *LTE115: Cell Bandwidth - 5 MHz*
Needs to be enabled to use LTE 5 MHz carriers.
- *LTE116: Cell Bandwidth - 3 MHz*
Needs to be enabled to use LTE 3 MHz carriers.
- *LTE117: Cell Bandwidth - 1.4 MHz*
It enables LTE 1.4 MHz carriers.

- *LTE1103: Load-based Power Saving for Multilayer Networks*
LTE1103 must be activated to use load-based power saving for multilayer networks.
- *LTE1203: Load-based Power Saving with Tx Path Switching Off*
LTE1203 must be activated to use load-based power saving with Tx path switching off.
- *LTE2508: BTS Embedded Power Meter for Energy Efficiency Monitoring*
LTE2508 must be activated to use BTS embedded power meter for energy efficiency monitoring.
- *LTE1891: eNodeB Power Saving - Micro DTX*
LTE1891 must be enabled to use Micro DTX extension.

5.2.4 Nokia AirScale RRH 2T2R B11 120 W (FHKA)

FHKA is introduced by LTE3184: Nokia AirScale RRH 2T2R B11 120 W (FHKA).

Functional description

Table 99 FHKA functional specification

Property	Value
Output power	2x60 W
QAM	256 QAM (DL) 64 QAM (UL)
Number of TXRX	2T2R
Outdoor installation	Yes
Supported technologies (standalone and MSR)	FDD-LTE, 5G-ready
TX frequency range	1475.9-1495.9 MHz
RX frequency range	1427.9-1447.9 MHz
DL filter bandwidth	20 MHz
UL filter bandwidth	20 MHz
iBW (instantaneous bandwidth)	20 MHz
oBW (occupied bandwidth)	20 MHz
Number of carriers per pipe	Up to 4
Supported bandwidths	5, 10 MHz
PIM cancellation	No

Interfaces

Figure 26 FHKA interfaces

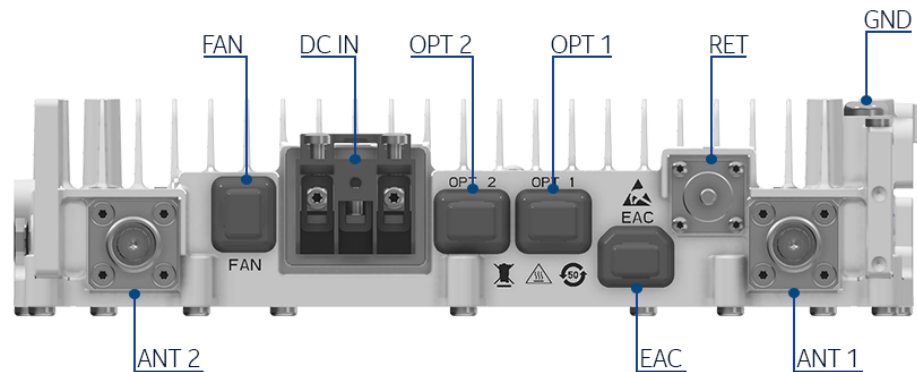

Table 100 FHKA interfaces

Interface	Label on the HW	Number of interfaces	Connector type	Additional info
Power Connector	DC IN	1	3-pole screw terminal	Allowed wire gauge: 3.3 mm ² to 35 mm ² (12 AWG to 2 AWG)
Antenna connector	ANT	2	4.3-10	-
Remote Electrical Tilt	RET	1	8-pin circular	RS-485
External Alarm Connection	EAC	1	USB 3.0 Type-A	4 alarm inputs and 1 control output
Optical interface	OPT	2	SFP+	6 Gbps, OBSAI, Nokia IP seal
Ground		1	M8 or dual M5 screws	-
Fan	Fan	1	2-pin Micro-Fit	-



WARNING! Risk of electric shock

Before turning RF power on, RF ports have to be terminated by nominal 50 Ω load (for example, feeder with antenna). However, if these conditions are not met, the plastic caps that are delivered within the unused RF ports should remain in place. The plastic caps isolate RF port from the environment, and thus provide electric shock security in case RF power is accidentally on.

Antenna Line Devices (ALDs) support

Table 101 FHKA ALD support

ALD support	Value
AISG	RET: AISG 2.0
Proprietary AISG1.1	No
CWA (for non-AISG installations)	No
Voltage	RET: 14.5 V
Power on RET port	30 W

Functional block diagram

Figure 27 FHKA functional block diagram

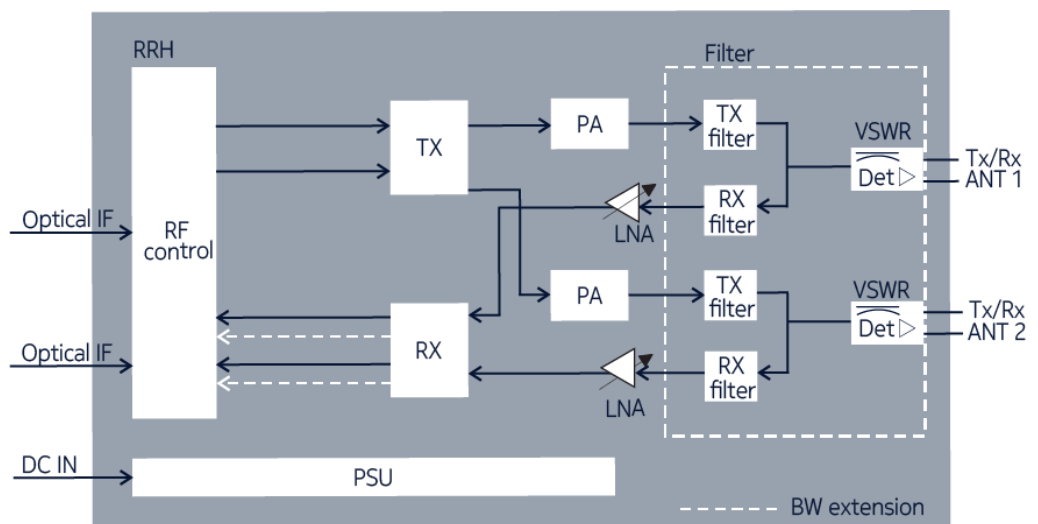

Electrical specifications

Table 102 FHKA electrical specifications

Property	Value
Nominal supply voltage	-48.0 V DC
Nominal input voltage range	-40.5 V DC to -57.0 V DC
Extended input voltage range	-36.0 V DC to -40.5 V DC -57.0 V DC to -60.0 V DC



Note: The minimum startup voltage is -40.5 V DC. If the input voltage is below/beyond extended limits, the unit might shut down.

Power consumption

Typical power consumption [W] for 48VDC input, at 25°C, representative of typical product performance under the same conditions (HW variant, SW version, configuration, environment, and so on) with +/- 10% margin. Average = (6h low hour load, 10h medium hour load and 8h busy hour load) / 24h

Configurations explained on examples:

- GSM/WCDMA: 2/2/2 = three sectors, two carriers/TRXs per sector
- LTE:
 - o 2/2/2 2Tx = three sectors, two carriers per sector, 2Tx per carrier
 - o 1+1/1+1/1+1 4Tx = three dual-band sectors, one carrier per sector per band, 4Tx per carrier

Some radio units are capable of providing only one sector coverage. Then the power values in the table consider deployment of three radio units.

Table 103 FHKA power consumption in LTE mode

Configuration	Output power per carrier [W]	Power consumption ETSI 202706 average load $P_{RRH, static}$	Power consumption ETSI 202706 busy hour load $P_{BH, RRH, static}$	Power consumption 100% RF power load $P_{100\% RRH}$
1/1/1 2Tx	20+20	383	447	581
1/1/1 2Tx	40+40	508	631	908
1/1/1 2Tx	60+60	609	790	1218

Power reduction



Note: The maximum power reduction (dlCellPwrRed) value is 20 dB. High power reduction values may cause radio outages.

Related optional items

- AMPA Pole Mounting Kit (30-120 mm)
- FMNC AirScale 1.0 Medium Fan Kit
- AMLA Flat mount adapter bracket
- FMNH AirScale Ladder Mount Kit
- FPKA/FPKC Flexi Pole Mounting Kit
- AMFQ AirScale RAS2 kit for RRH 600

Installation options

- wall installation
- pole installation
- flat mount without fans on wall or pole
- vertical book mount without fans
- horizontal book mount with fans
- inside the Radio Antenna System (RAS) without fans



NOTICE: Install this RRH in a vertical orientation with connectors on the bottom side, to ensure convection cooling. For horizontal installation fans are required.

Dimensions and weight

Table 104 FHKA dimensions and weight

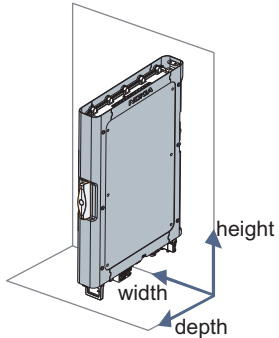
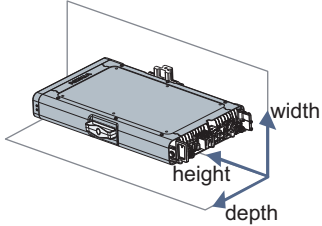
Property	Value	Dimensions orientation
Height	Core RRH: 591.6 mm (23.3 in.) With cover, handle, and unit bracket: 600 mm (23.6 in.) With cover, handle, unit bracket, and fan kit: 630.2 mm (24.8 in.)	<p>Dimensions orientation in vertical mount with cover</p> 
Depth	Core RRH: 320 mm (12.6 in.) With cover, handle, and unit bracket: 424 mm (16.7 in.) With cover, handle, unit bracket, and fan kit: 424 mm (16.7 in.)	
Width	Core RRH: 77.5 mm (3 in.) With cover, handle, and unit bracket: 80 mm (3.1 in.) With cover, handle, unit bracket, and fan kit : 80 mm (3.1 in.) With cover, handle, unit bracket, and fan kit (unit bracket rotated 90 degrees for horizontal mounting) : 143 mm (5.6 in.)	<p>Dimensions orientation in horizontal mount with cover and fan</p> 
Weight	Core RRH: 12.5 kg (27.5 lb) With cover, handle and unit mounting bracket: 14.4 kg (31.7 lb) With cover, handle, unit mounting bracket, and fan kit: 15.5 kg (34.2 lb)	
Volume	Core RRH: 12.5 l With cover, handle, and unit bracket: 20.3 l With cover, handle, unit bracket, and fan kit: 32 l	

Environmental specifications

Table 105 FHKA environmental specifications

Property	Value
Maximum operational outdoor temperature in the shade, assuming wind speed is 3 m/s (at	55°C (131°F)

Table 105 FHKA environmental specifications (Cont.)

Property	Value
constant high ambient temperature, maximum output power might be limited)	
Maximum operational outdoor temperature in the sun, assuming wind speed is 3 m/s (at constant high ambient temperature, maximum output power might be limited)	50°C (122°F)
Maximum indoor temperature, assuming wind speed is 0 m/s, valid for fanless products (at constant high ambient temperature, maximum output power might be limited)	40°C (104°F)
Minimum operational temperature (including cold start)	-40°C (-40°F)
IP rating	IP65

LTE3184 feature interdependencies

The *LTE3184: FHKA AirScale RRH 2T2R B11 120 W* feature is impacted by the following features:

- *LTE114: Cell Bandwidth - 10 MHz*
Needs to be enabled to use LTE 10 MHz carriers.
- *LTE115: Cell Bandwidth - 5 MHz*
Needs to be enabled to use LTE 5 MHz carriers.
- *LTE614: Distributed Site*
With this feature, FHKA can be used in distributed sites with up to 23 km fiber length to the system module.
- *LTE977: RF chaining*
With this feature, FHKA supports chains of up to 3 radio units.
- *LTE1103: Load based Power Saving for multi-layer networks or LTE1203: Load based Power Saving mode with Tx power reduction or path switching off*
One of these features must be enabled to use the PA shutdown feature.
- *LTE1891: eNode B power saving - Micro DTX*
This feature must be enabled to use Micro DTX extension.
- *LTE2508: BTS Embedded Power Meter for Energy Efficiency Monitoring*
With this feature FHKA can use BTS Embedded Power Meter for Energy Efficiency Monitoring.

5.2.5 Nokia AirScale RRH 2T2R B28 120 W (FHPD)

FHPD is introduced by LTE3181: AirScale RRH 2T2R B28 120 W (FHPD).

Functional description

Table 106 FHPD functional specification

Property	Value
Output power	2x60 W

Table 106 FHPD functional specification (Cont.)

Property	Value
Number of TXRX	2T2R
Outdoor installation	Yes
Supported technologies (standalone and MSR)	FDD-LTE, 5G-ready
TX frequency range	758-803 MHz
RX frequency range	703-748 MHz
DL filter bandwidth	45 MHz
UL filter bandwidth	45 MHz
iBW (instantaneous bandwidth)	45 MHz
oBW (occupied bandwidth)	45 MHz
Supported bandwidths	3, 5, 10, 15, 20 MHz

Interfaces

Figure 28 FHPD interfaces

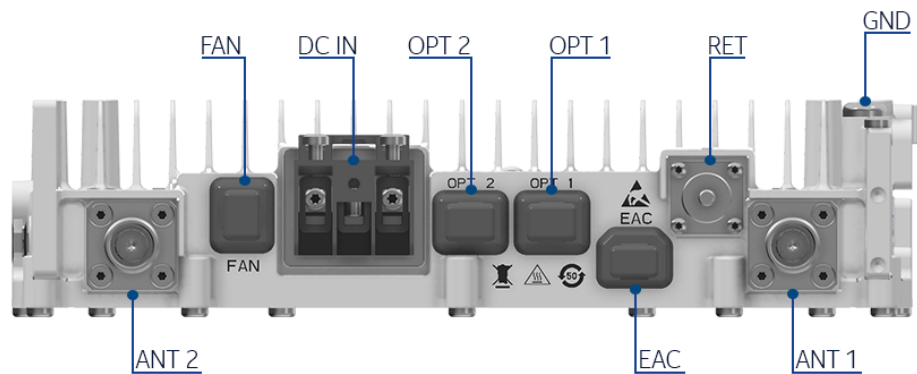



Table 107 FHPD interfaces

Interface	Label on the HW	Number of interfaces	Connector type	Additional info
Power Connector	DC IN	1	3-pole screw terminal	Allowed wire gauge: 3.3 mm ² to 35 mm ² (12 AWG to 2 AWG)
Antenna connector	ANT	2	4.3-10	-

Table 107 FHPD interfaces (Cont.)

Interface	Label on the HW	Number of interfaces	Connector type	Additional info
Remote Electrical Tilt	RET	1	8-pin circular	RS-485
External Alarm Connection	EAC	1	USB 3.0 Type-A	4 alarm inputs and 1 control output
Optical interface	OPT	2	SFP+	6 Gbps, OBSAI, Nokia IP seal
Ground		1	M8 or dual M5 screws	-
Fan	Fan	1	2-pin Micro-Fit	-



WARNING! Risk of electric shock

Before turning RF power on, RF ports have to be terminated by nominal 50 Ω load (for example, feeder with antenna). However, if these conditions are not met, the plastic caps that are delivered within the unused RF ports should remain in place. The plastic caps isolate RF port from the environment, and thus provide electric shock security in case RF power is accidentally on.

Antenna Line Devices (ALDs) support

Table 108 FHPD ALD support

ALD support	Value
AISG	RET: AISG 2.0
CWA (for non-AISG installations)	No
Voltage	RET: 14.5 V
Power on RET port	30 W

Functional block diagram

Figure 29 FHPD functional block diagram

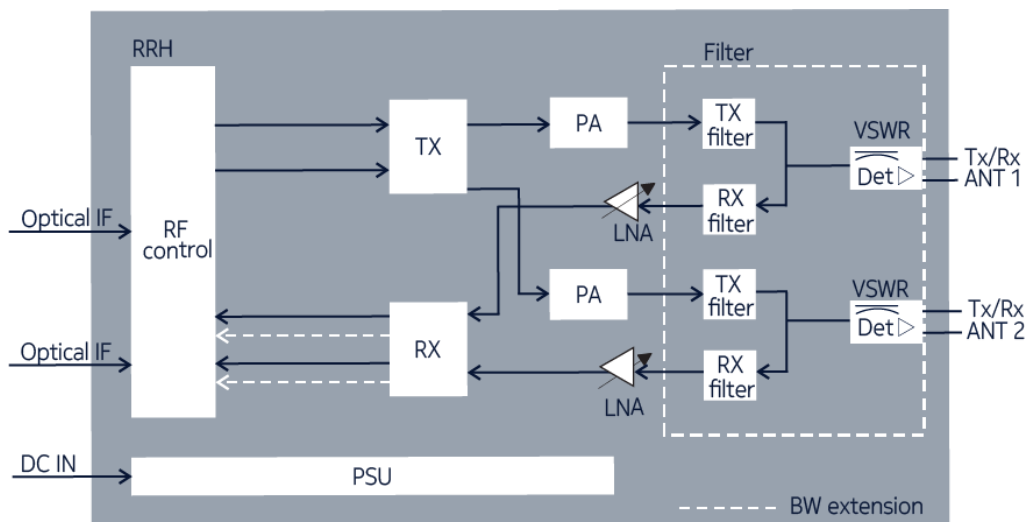

Electrical specifications

Table 109 FHPD electrical specifications

Property	Value
Nominal supply voltage	-48.0 V DC
Nominal input voltage range	-40.5 V DC to -57.0 V DC
Extended input voltage range	-36.0 V DC to -40.5 V DC -57.0 V DC to -60.0 V DC



Note: The minimum startup voltage is -40.5 V DC. If the input voltage is below/beyond extended limits, the unit might shut down.

Power consumption

Typical power consumption [W] for 48VDC input, at 25°C, representative of typical product performance under the same conditions (HW variant, SW version, configuration, environment, and so on) with +/- 10% margin. Average = (6h low hour load, 10h medium hour load and 8h busy hour load) / 24h

Configurations explained on examples:

- GSM/WCDMA: 2/2/2 = three sectors, two carriers/TRXs per sector
- LTE:
 - o 2/2/2 2Tx = three sectors, two carriers per sector, 2Tx per carrier
 - o 1+1/1+1/1+1 4Tx = three dual-band sectors, one carrier per sector per band, 4Tx per carrier

Some radio units are capable of providing only one sector coverage. Then the power values in the table consider deployment of three radio units.

Table 110 FHPD power consumption in LTE mode

Configuration	Output power per carrier [W]	Power consumption ETSI 202706 average load $P_{RRH, static}$	Power consumption ETSI 202706 busy hour load $P_{BH, RRH, static}$	Power consumption 100% RF power load $P_{100\% RRH}$
1/1/1 2Tx	20+20	432	499	616
1/1/1 2Tx	40+40	567	686	924
1/1/1 2Tx	60+60	663	834	1203

Table 111 FHPD power reduction in 256 QAM

Single carrier [dB]	Dual carrier [dB]
0.7	0.8



Note: The maximum power reduction ($d1CellPwrRed$) value is 20 dB. High power reduction values may cause radio outages.

Related optional items

- AMPA Pole Mounting Kit (30-120 mm)
- FMNC AirScale 1.0 Medium Fan Kit
- AMLA Flat mount adapter bracket
- FMNH AirScale Ladder Mount Kit
- FPKA/FPKC Flexi Pole Mounting Kit
- AMFQ AirScale RAS2 kit for RRH 600

Installation options

- wall installation
- pole installation
- flat mount without fans on wall or pole
- vertical book mount without fans
- horizontal book mount with fans
- inside the Radio Antenna System (RAS) without fans



NOTICE: Install this RRH in a vertical orientation with connectors on the bottom side, to ensure convection cooling. For horizontal installation fans are required.

Dimensions and weight

Table 112 FHPD dimensions and weight

Property	Value	Dimensions orientation
Height	Core RRH: 591.6 mm (23.3 in.) With cover, handle, and unit bracket: 600 mm (23.6 in.) With cover, handle, unit bracket, and fan kit: 630.2 mm (24.8 mm)	<p>Dimensions orientation in vertical mount with cover</p>  <p>Dimensions orientation in horizontal mount with cover and fan</p> 
Depth	Core RRH: 320 mm (12.6 in.) With cover, handle, and unit bracket: 424 mm (16.7 in.) With cover, handle, unit bracket, and fan kit: 424 mm (16.7 in.)	
Width	Core RRH: 77.5 mm (3 in.) With cover, handle, and unit bracket: 80 mm (3.1 in.) With cover, handle, unit bracket, and fan kit : 80 mm (3.1 in.) With cover, handle, unit bracket, and fan kit (unit bracket rotated 90 degrees for horizontal mounting) : 143 mm (5.6 in.)	
Weight	Core RRH: 13.5 kg (29.8 lb)	

Table 112 FHPD dimensions and weight (Cont.)

Property	Value	Dimensions orientation
	With cover, handle and unit mounting bracket: 15.4 kg (33.9 lb) With cover, handle, unit mounting bracket, and fan kit: 16.5 kg (36.4 lb)	
Volume	Core RRH: 12.5 l With cover, handle, and unit bracket: 20.3 l With cover, handle, unit bracket, and fan kit: 32 l	

Environmental specifications

Table 113 FHPD environmental specifications

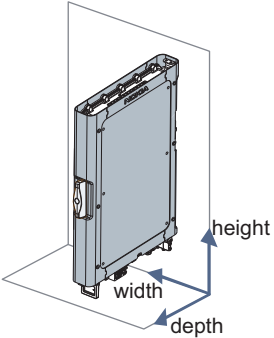
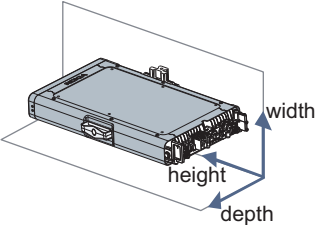
Property	Value
Maximum operational outdoor temperature in the shade, assuming wind speed is 3 m/s (at constant high ambient temperature, maximum output power might be limited)	55°C (131°F)
Maximum operational outdoor temperature in the sun, assuming wind speed is 3 m/s (at constant high ambient temperature, maximum output power might be limited)	50°C (122°F)
Maximum indoor temperature, assuming wind speed is 0 m/s, valid for fanless products (at constant high ambient temperature, maximum output power might be limited)	40°C (104°F)
Minimum operational temperature (including cold start)	-40°C (-40°F)
IP rating	IP65

LTE3181 feature interdependencies

The *LTE3181:AirScale RRH 2T2R B28 120W FHPD Go to Actions* feature is impacted by the following features:

- *LTE112: Cell Bandwidth - 20 MHz*
It enables LTE 20 MHz carriers.
- *LTE113: Cell Bandwidth - 15 MHz*
It enables LTE 15 MHz carriers.
- *LTE114: Cell Bandwidth - 10 MHz*
It enables LTE 10 MHz carriers.
- *LTE115: Cell Bandwidth - 5 MHz*
It enables LTE 5 MHz carriers.
- *LTE116: Cell Bandwidth - 3 MHz*

It enables LTE 3 MHz carriers.

- *LTE614: Distributed Site*
With LTE614 FHPD can be used in distributed sites with up to 23 km fiber length to the system module.
- *LTE977: RF chaining*
With LTE977 FHPD supports chains of up to four radio units.
- *LTE2829: Supported RAS Installation options in FL17 Release*
With LTE2829 RAS installation options are defined.
- FHPD supports the following power saving features:
 - *LTE1103: Load based Power Saving for multi-layer networks*
 - *LTE1203: Load based Power Saving with Tx path switching off*
 - *LTE1891: eNode B power saving - Micro DTX*
 - *LTE2508: BTS Embedded Power Meter for Energy Efficiency Monitoring*

5.2.6 Nokia AirScale RRH 2T2R 700 120 W (FHPG)

FHPG is introduced by LTE4167: Nokia AirScale RRH 2T2R 700 120W (FHPG).

Functional description

Table 114 FHPG functional specification

Property	Value
Output power	2x60 W
QAM	64 QAM / 256 QAM (DL) 64 QAM / 256 QAM (UL)
Number of TXRX	2T2R
Outdoor installation	Yes
Supported technologies (standalone and MSR)	FDD-LTE, 5G-ready
TX frequency range	B28: DL 773 - 783 MHz
RX frequency range	B28: UL 718 - 728 MHz
DL filter bandwidth	10 MHz
UL filter bandwidth	10 MHz
iBW (instantaneous bandwidth)	10 MHz
oBW (occupied bandwidth)	10 MHz
Number of carriers per pipe	Up to 4
Supported bandwidths	3, 5, 10 MHz

Interfaces

Figure 30 FHPG interfaces

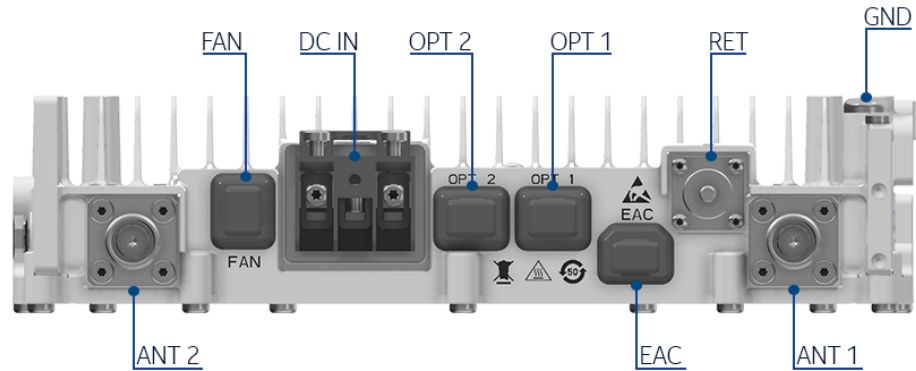

Table 115 FHPG interfaces

Interface	Label on the HW	Number of interfaces	Connector type	Additional info
Power Connector	DC IN	1	3-pole screw terminal	Allowed wire gauge: 3.3 mm ² to 35 mm ² (12 AWG to 2 AWG)
Antenna connector	ANT	2	4.3-10	-
Remote Electrical Tilt	RET	1	8-pin circular	RS-485
External Alarm Connection	EAC	1	USB 3.0 Type-A	4 alarm inputs and 1 control output
Optical interface	OPT	2	SFP+	6 Gbps, OBSAI, Nokia IP seal
Fan	Fan	1	2-pin Micro-Fit	-
Grounding		1	M8 or dual M5 screws	-



WARNING! Risk of electric shock

Before turning RF power on, RF ports have to be terminated by nominal 50 Ω load (for example, feeder with antenna). However, if these conditions are not met, the plastic caps that are delivered within the unused RF ports should remain in place. The plastic caps isolate RF port from the environment, and thus provide electric shock security in case RF power is accidentally on.

Antenna Line Devices (ALDs) support

Table 116 FHPG ALD support

ALD support	Value
AISG	RET: AISG 2.0
CWA (for non-AISG installations)	No
Voltage	RET 14.5V
Power per port	30 W

Functional block diagram

Figure 31 FHPG functional block diagram

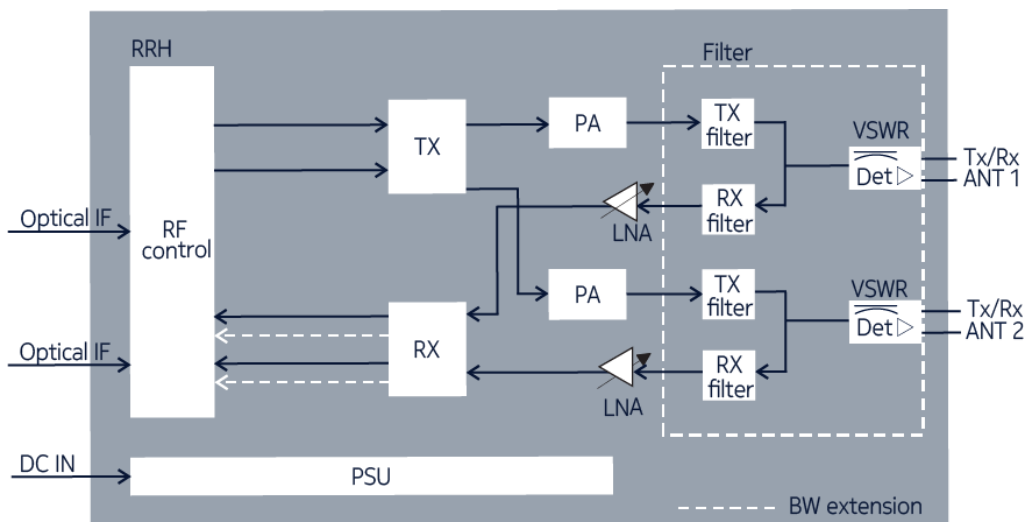

Electrical specifications

Table 117 FHPG electrical specifications

Property	Value
Nominal supply voltage	-48.0 V DC
Nominal input voltage range	-40.5 V DC to -57.0 V DC
Extended input voltage range	-36.0 V DC to -40.5 V DC -57.0 V DC to -60.0 V DC



Note: The minimum startup voltage is -40.5 V DC. If the input voltage is below/beyond extended limits, the unit might shut down.

Power consumption

Typical power consumption [W] for 48VDC input, at 25°C, representative of typical product performance under the same conditions (HW variant, SW version, configuration, environment, and so on) with +/- 10% margin. Average = (6h low hour load, 10h medium hour load and 8h busy hour load) / 24h

Configurations explained on examples:

- GSM/WCDMA: 2/2/2 = three sectors, two carriers/TRXs per sector
- LTE:
 - o 2/2/2 2Tx = three sectors, two carriers per sector, 2Tx per carrier
 - o 1+1/1+1/1+1 4Tx = three dual-band sectors, one carrier per sector per band, 4Tx per carrier

Some radio units are capable of providing only one sector coverage. Then the power values in the table consider deployment of three radio units.

Table 118 FHPG power consumption in LTE mode

Configuration	Output power per carrier [W]	Power consumption ETSI 202706 average load $P_{RRH, static}$	Power consumption ETSI 202706 busy hour load $P_{BH RRH, static}$	Power consumption 100% RF power load $P_{100\% RRH}$
1/1/1 2Tx	20+20	432	499	616
1/1/1 2Tx	40+40	567	686	924
1/1/1 2Tx	60+60	663	834	1203

Power reduction



Note: The maximum power reduction (`dlCellPwrRed`) value is 20 dB. High power reduction values may cause radio outages.

Related optional items

- AMPA Pole Mounting Kit (30-120 mm)
- FMNC AirScale 1.0 Medium Fan Kit
- AMLA Flat mount adapter bracket
- FMNH AirScale Ladder Mount Kit
- FPKA/FPKC Flexi Pole Mounting Kit
- AMFQ AirScale RAS2 kit for RRH 600

Installation options

- wall installation
- pole installation
- flat mount without fans on wall or pole
- vertical book mount without fans
- horizontal book mount with fans
- inside the Radio Antenna System (RAS) without fans



NOTICE: Install this RRH in a vertical orientation with connectors on the bottom side, to ensure convection cooling. For horizontal installation fans are required.

Dimensions and weight

Table 119 FHPG dimensions and weight

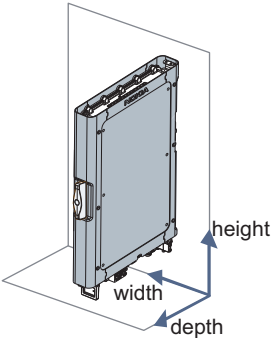
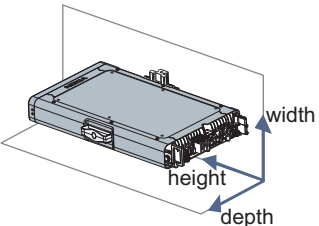
Property	Value	Dimensions orientation
Height	Core RRH: 591.6 mm (23.3 in.) With cover, handle, and unit bracket: 600 mm (23.6 in.) With cover, handle, unit bracket, and fan kit: 630.2 mm (24.8 mm)	<p>Dimensions orientation in vertical mount with cover</p> 
Depth	Core RRH: 320 mm (12.6 in.) With cover, handle, and unit bracket: 424 mm (16.7 in.) With cover, handle, unit bracket, and fan kit: 424 mm (16.7 in.)	
Width	Core RRH: 77.5 mm (3 in.) With cover, handle, and unit bracket: 80 mm (3.1 in.) With cover, handle, unit bracket, and fan kit : 80 mm (3.1 in.) With cover, handle, unit bracket, and fan kit (unit bracket rotated 90 degrees for horizontal mounting) : 143 mm (5.6 in.)	<p>Dimensions orientation in horizontal mount with cover and fan</p> 
Weight	Core RRH: 13.5 kg (29.8 lb) With cover, handle and unit mounting bracket: 15.4 kg (33.9 lb) With cover, handle, unit mounting bracket, and fan kit: 16.5 kg (36.4 lb)	
Volume	Core RRH: 12.5 l With cover, handle, and unit bracket: 20.3 l With cover, handle, unit bracket, and fan kit: 32 l	

Environmental specifications

Table 120 FHPG environmental specifications

Property	Value
Maximum operational outdoor temperature (in the shade)	55°C (131°F)

Table 120 FHPG environmental specifications (Cont.)

Property	Value
Maximum operational outdoor temperature (in the sun)	55°C (131°F)
Maximum indoor temperature	45°C (113°F)
Minimum operational temperature	-40°C (-40°F)
IP rating	IP65

LTE4167 feature interdependencies

LTE4167: FHPG AirScale RRH 2T2R 700 120W is impacted by the following features:

- *LTE 114: Cell Bandwidth - 10 MHz* enables LTE 10 MHz carriers.
- *LTE 115: Cell Bandwidth - 5 MHz* enables LTE 5 MHz carriers.
- *LTE 116: Cell Bandwidth - 3 MHz* enables LTE 3 MHz carriers.
- With *LTE 614: Distributed Site*, FHPG can be used in distributed sites with up to 23km fiber length to the system module.
- With *LTE977: RF Chaining*, FHPG supports chains of up to four radio units.
- *LTE1103: Load based Power Saving for multi-layer networks* enables Load based Power Saving for multi-layer networks.
- *LTE1203: Load based Power Saving with Tx path switching off* enables Load based Power Saving with Tx path switching off.
- *LTE1891: eNode B power saving - Micro DTX* enables Micro DTX extension.
- FHPG supports *LTE2508: BTS Embedded Power Meter for Energy Efficiency Monitoring*

5.2.7 Nokia AirScale RRH 2T4R B1/n1 120 W (AHGA)

AHGA is introduced by LTE3764/SR001768/5GC002304: Nokia AirScale RRH 2T4R B1/n1 120W (AHGA).

Functional description

Table 121 AHGA functional specification

Property	Value
Output power	2x60 W
QAM	256 QAM (DL) 64 QAM (UL)
Number of TXRX	2T4R
Outdoor installation	Yes
Supported technologies (standalone and MSR)	WCDMA, FDD-LTE, 5G NR LTE-WCDMA
IoT support	NB-IoT in band, guard band (GB), standalone (SA)

Table 121 AHGA functional specification (Cont.)

Property	Value
TX frequency range	2110 - 2170 MHz
RX frequency range	1920 - 1980 MHz
DL filter bandwidth	60 MHz
UL filter bandwidth	60 MHz
iBW (instantaneous bandwidth)	60 MHz
oBW (occupied bandwidth)	60 MHz
Number of carriers per pipe	Up to 8 carriers in total for all supported RATs
Supported bandwidths	5, 10, 15, 20 MHz
PIM cancellation	Yes

Interfaces

Figure 32 AHGA interfaces

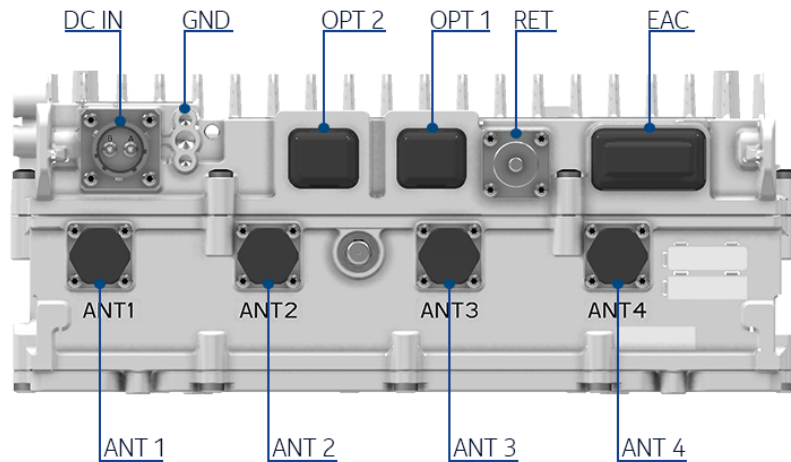

Table 122 AHGA interfaces

Interface	Label on the HW	Number of interfaces	Connector type	Additional info
Power Connector	DC IN	1	Low power circular	APPA, APPB, APPC
Antenna connector	ANT	4	4.3-10	-
Remote Electrical Tilt	RET	1	8-pin circular	RS-485

Table 122 AHGA interfaces (Cont.)

Interface	Label on the HW	Number of interfaces	Connector type	Additional info
Optical interface	SFP	2	SFP+	9.8 Gbps, CPRI; Nokia IP seal
External Alarm Connection	EAC	1	MDR26	4 alarm inputs and 1 control output
Grounding	GND	1	M8 or dual M5 screws	-
Fan	FAN	1	Nokia fan	Located on the opposite side



WARNING! Risk of electric shock

Before turning RF power on, RF ports have to be terminated by nominal 50 Ω load (for example, feeder with antenna). However, if these conditions are not met, the plastic caps that are delivered within the unused RF ports should remain in place. The plastic caps isolate RF port from the environment, and thus provide electric shock security in case RF power is accidentally on.

Antenna Line Devices (ALDs) support

Table 123 AHGA ALD support

ALD support	Value
AISG	ANT1, ANT3: AISG 2.0/3.0 ANT2, ANT4: AISG 3.0 ping receiver RET: AISG 2.0/3.0
Voltage	ANT1, ANT3, RET: 14.5 V
Power per port	30 W, 45 W total

Functional block diagram

Figure 33 AHGA functional block diagram

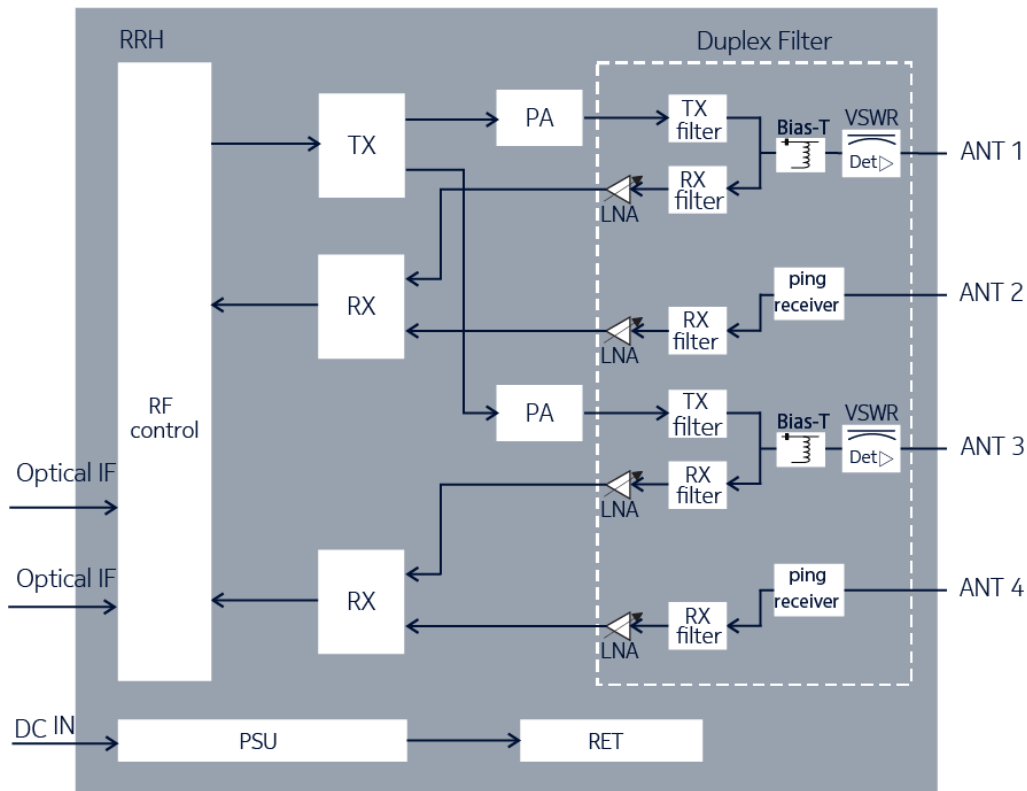

Electrical specifications

Table 124 AHGA electrical specifications

Property	Value
Nominal supply voltage	-48.0 V DC
Nominal input voltage range	-40.5 V DC to -57.0 V DC
Extended input voltage range	-36.0 V DC to -40.5 V DC -57.0 V DC to -60.0 V DC



Note: The minimum start-up voltage is -40.5 V DC. If the input voltage is below/beyond the extended limits, the unit might shut down.

Power consumption

Typical power consumption [W] for 48VDC input, at 25°C, representative of typical product performance under the same conditions (HW variant, SW version, configuration, environment, and so on) with +/- 10% margin. Average = (6h low hour load, 10h medium hour load and 8h busy hour load) / 24h

Configurations explained on examples:

- GSM/WCDMA: 2/2/2 = three sectors, two carriers/TRXs per sector
- LTE:
 - o 2/2/2 2Tx = three sectors, two carriers per sector, 2Tx per carrier

o 1+1/1+1/1+1 4Tx = three dual-band sectors, one carrier per sector per band, 4Tx per carrier

Some radio units are capable of providing only one sector coverage. Then the power values in the table consider deployment of three radio units.

Table 125 AHGA power consumption in LTE mode

Configuration	Output Power per carrier (W)	Power consumption (W), ETSI 202706 average load P_{RRH} , static	Power consumption (W), ETSI 202706 busy hour load P_{BH} $_{RRH}$, static	Power consumption (W), 100% RF power load $P_{100\% RRH}$
1/1/1 2Tx	2x60	634	784	1150
1/1/1 2Tx	2x40	537	638	867
1/1/1 2Tx	2x30	499	581	759
1/1/1 2Tx	2x20	456	514	625

Power reduction



Note: The maximum power reduction (`dlCellPwrRed`) value is 20 dB. High power reduction values may cause radio outages.

Related optional items

- ASFA AirScale 2 fan unit 300 (473968A)
- APAA AirScale AC-DC Power Unit 760W (473936A)
- AMAA AirScale 2 casing for RRH aux-units (474141A):
 - APAC AirScale AC PDU 1 to 3 (474142A)
 - APAA AirScale AC-DC Power Unit 760W (473936A) - maximum three units per one AMAA
- AMGC AirScale2 cover 300 x 101-125 (474269A)
- AMBD AirScale bookmount kit 76-100 (474276A) - AHGA v101 (474254A.101) use AMBD (474276A) unit bracket and AMBE (474277A) secondary bracket for bookmount installation
- AMBE AirScale bookmount kit 101-125 (474277A) - AHGA v202 (474254A.202) uses whole AMBE (474277A) bookmount kit for bookmount installation
- FPKA Flexi Pole Mounting Kit (30-120 mm) (471649A)
- FPKC Flexi Pole Mounting Kit (60-300 mm) (472821A)
- AMPA Pole Mounting Kit (30-120 mm) (473879A)
- AMFA AirScale 2 FPKx fixing adapter (474289A)
- AMFB AirScale2 RAS2 fixing kit 300 mm (474290A)
- AMFC AirScale 2 19" rack fixing 300 (474291A)
- AMFN AirScale 2 casing adapter RRH 300 (474664A)
- AMRA AirScale one clip bracket 51-125 (474580A)
- AMRC AirScale one clip rail 600 mm (474583A)
- ASAA AirScale 2 MDR26-open EAC cable 5 m (474288A)
- APPA AirScale 2 26A DC plug 3.3-10 mm² (474281A)
- ACPA AirScale 2 Fiber Protection (474297A)

Installation options

- Pole mounting: vertical, horizontal with optional fan
- Wall mounting: vertical, horizontal with optional fan
- Compatible to RAS mounting: vertical
- Bookshelf mounting
- One-clip rail mounting



NOTICE: Install this RRH in a vertical orientation with connectors on the bottom side, to ensure convection cooling. For horizontal installation fans are required.

Dimensions and weight

Table 126 AHGA dimensions and weight

Property	Value	Dimensions orientation
Height	Core RRH: 336 mm (13.2 in.) With upper and lower mounting brackets: 427.5 mm (16.8 in.)	
Width	295 mm (11.6 in.)	
Depth	Core RRH: 100 mm (3.9 in.) With mounting brackets: 124 mm (4.9 in.)	
Weight	11 kg (24.3 lb)	
Volume	Without ID Cover: 10 l	

Environmental specifications

Table 127 AHGA environmental specifications

Property	Value
Maximum operational outdoor temperature (in the shade)	55°C (131°F)
Maximum operational outdoor temperature (in the sun)	55°C (131°F)
Maximum indoor temperature	45°C (113°F)
Minimum operational temperature	-40°C (-40°F)
IP rating	IP65

LTE3764 feature interdependencies

The *LTE3764: AirScale RRH 2T4R B1 120W AHGA* feature is impacted by the following features:

- *LTE112: Cell Bandwidth - 20 MHz* enables to use LTE 20 MHz carriers.
- *LTE113: Cell Bandwidth - 15 MHz* enables to use LTE 15 MHz carriers.
- *LTE114: Cell Bandwidth - 10 MHz* enables to use LTE 10 MHz carriers.
- *LTE115: Cell Bandwidth - 5 MHz* enables to use LTE 5 MHz carriers.

- With *LTE614: Distributed Site*, AHGA can be used in distributed sites with up to 23 km fiber length to the system module.
- *LTE1103: Load based Power Saving for multi-layer networks* enables to use Load based Power Saving for multi-layer networks.
- *LTE1203: Load based Power Saving with Tx path switching off* enables to use Load based Power Saving with Tx path switching off.
- *LTE2508: BTS Embedded Power Meter for Energy Efficiency Monitoring* enables to use BTS Embedded Power Meter for Energy Efficiency Monitoring.
- *LTE2541: Nokia CPRI RRH/RFM chaining* provides support for chaining.
- *LTE3036: Micro DTX extension* enables to use Micro DTX extension.

5.2.8 Nokia AirScale RRH 2T4R B1 120 W (AHGC)

AHGC is introduced by LTE4510: Nokia AirScale RRH 2T4R B1 120 W (AHGC).

Functional description

Table 128 AHGC functional specification

Property	Value
Output power	2x60 W
QAM	256 QAM (DL) 64 QAM (UL)
Number of TXRX	2T4R
Outdoor installation	Yes
Supported technologies (standalone and MSR)	FDD-LTE, 5G-ready
IoT support	NB-IoT in band, guard band (GB), standalone (SA)
TX frequency range	2110 - 2130 MHz
RX frequency range	1920 - 1940 MHz
DL filter bandwidth	20 MHz
UL filter bandwidth	20 MHz
iBW (instantaneous bandwidth)	20 MHz
oBW (occupied bandwidth)	20 MHz
Number of carriers per pipe	Up to 4
Supported bandwidths	5, 10, 15, 20 MHz
PIM cancellation	Yes

Interfaces

Figure 34 AHGC interfaces

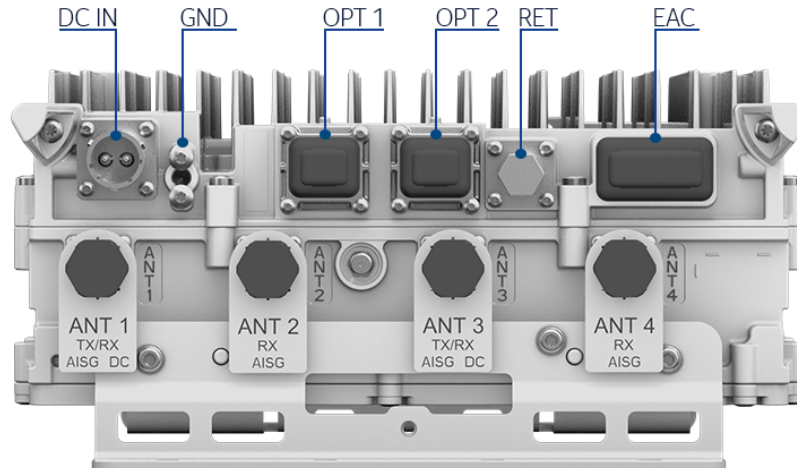

Table 129 AHGC interfaces

Interface	Label on the HW	Number of interfaces	Connector type	Additional info
Power Connector	DC IN	1	Low power circular	APPA, APPB, APPC
Antenna connector	ANT	4	4.3-10	-
Remote Electrical Tilt	RET	1	8-pin circular	RS-485
External Alarm Connection	EAC	1	MDR26	4 alarm inputs and 1 control output
Optical interface	OPT	2	SFP+	9.8 Gbps, CPRI; Nokia IP seal
Grounding		1	M8 or dual M5 screws	-
Fan	FAN	1	Nokia fan	Located on the opposite side



WARNING! Risk of electric shock

Before turning RF power on, RF ports have to be terminated by nominal 50 Ω load (for example, feeder with antenna). However, if these conditions are not met, the plastic caps that are delivered within the unused RF ports should remain in place. The plastic caps isolate RF port from the environment, and thus provide electric shock security in case RF power is accidentally on.

Antenna Line Devices (ALDs) support

Table 130 AHGC ALD support

ALD support	Value
AISG	ANT1, ANT3: AISG 2.0/3.0 ANT2, ANT4: AISG 3.0 ping receiver RET: AISG 2.0/3.0
Voltage	ANT1, ANT3, RET: 14.5 V
Power per port	30 W, 45 W total

Functional block diagram

Figure 35 AHGC functional block diagram

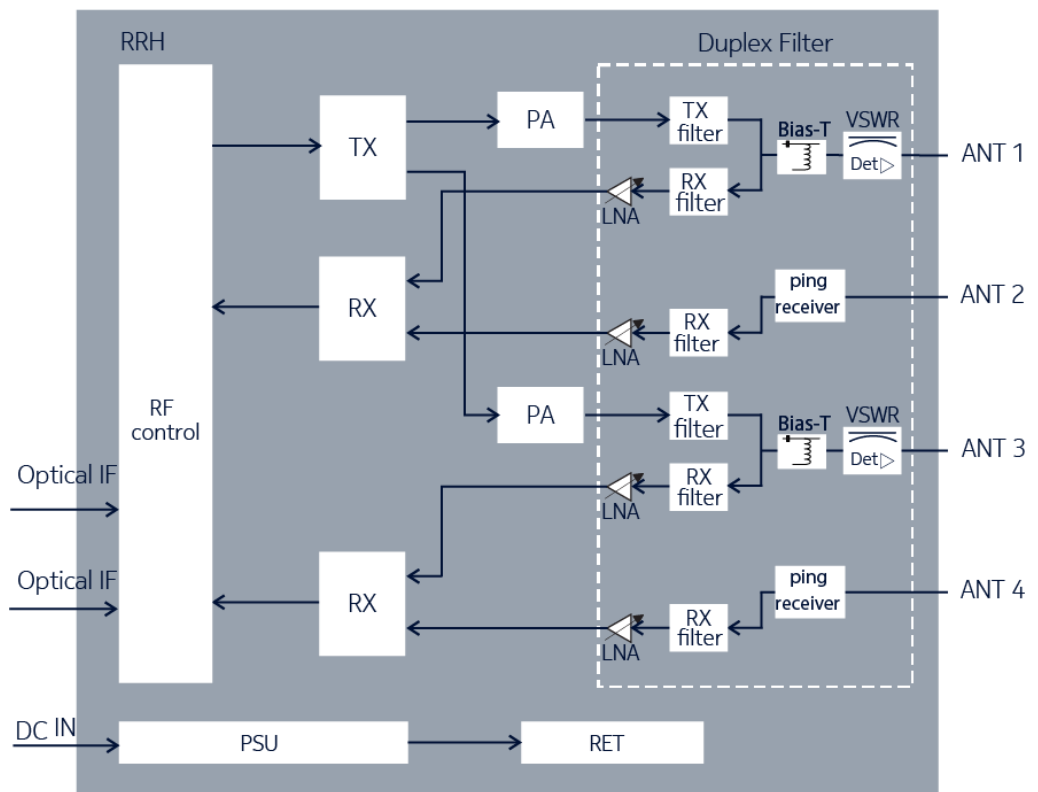

Electrical specifications

Table 131 AHGC electrical specifications

Property	Value
Nominal supply voltage	-48.0 V DC
Nominal input voltage range	-40.5 V DC to -57.0 V DC
Extended input voltage range	-36.0 V DC to -40.5 V DC -57.0 V DC to -60.0 V DC



Note: The minimum start-up voltage is -40.5 V DC. If the input voltage is below/beyond the extended limits, the unit might shut down.

Power consumption

Typical power consumption [W] for 48VDC input, at 25°C, representative of typical product performance under the same conditions (HW variant, SW version, configuration, environment, and so on) with +/- 10% margin. Average = (6h low hour load, 10h medium hour load and 8h busy hour load) / 24h

Configurations explained on examples:

- GSM/WCDMA: 2/2/2 = three sectors, two carriers/TRXs per sector
- LTE:
 - o 2/2/2 2Tx = three sectors, two carriers per sector, 2Tx per carrier
 - o 1+1/1+1/1+1 4Tx = three dual-band sectors, one carrier per sector per band, 4Tx per carrier

Some radio units are capable of providing only one sector coverage. Then the power values in the table consider deployment of three radio units.

Table 132 AHGC power consumption in LTE mode

Configuration	Output Power per carrier (W)	Power consumption (W), ETSI 202706 average load P _{RRH, static}	Power consumption (W), ETSI 202706 busy hour load P _{BH, RRH, static}	Power consumption (W), 100% RF power load P _{100% RRH}
1/1/1 2Tx	2x60	646	805	1205
1/1/1 2Tx	2x40	547	654	905
1/1/1 2Tx	2x30	507	593	786
1/1/1 2Tx	2x20	459	521	641

Power reduction



Note: The maximum power reduction (dlCellPwrRed) value is 20 dB. High power reduction values may cause radio outages.

Related optional items

- ASFA AirScale 2 fan unit 300 (473968A)
- APAA AirScale AC-DC Power Unit 760W (473936A)
- AMAA AirScale 2 casing for RRH aux-units (474141A):
 - APAC AirScale AC PDU 1 to 3 (474142A)
 - APAA AirScale AC-DC Power Unit 760W (473936A) - maximum three units per one AMAA
- AMGC AirScale2 cover 300 x 101-125 (474269A)
- AMBP AirScale book mount kit for AHGC (475324A)
- FPKA Flexi Pole Mounting Kit (30-120 mm) (471649A)
- FPKC Flexi Pole Mounting Kit (60-300 mm) (472821A)
- AMPA Pole Mounting Kit (30-120 mm) (473879A)
- AMFA AirScale 2 FPKx fixing adapter (474289A)

- AMFB AirScale2 RAS2 fixing kit 300 mm (474290A)
- AMFC AirScale 2 19" rack fixing 300 (474291A)
- AMFN AirScale 2 casing adapter RRH 300 (474664A)
- AMRA AirScale one clip bracket 51-125 (474580A)
- AMRC AirScale one clip rail 600 mm (474583A)
- ASAA AirScale 2 MDR26-open EAC cable 5 m (474288A)
- APPA AirScale 2 26A DC plug 3.3-10 mm² (474281A)
- ACPA AirScale 2 Fiber Protection (474297A)

Installation options

- Pole mounting: vertical, horizontal with optional fan
- Wall mounting: vertical, horizontal with optional fan
- Compatible to RAS mounting: vertical
- Bookshelf mounting
- One-clip rail mounting



NOTICE: Install this RRH in a vertical orientation with connectors on the bottom side, to ensure convection cooling. For horizontal installation fans are required.

Dimensions and weight

Table 133 AHGC dimensions and weight

Property	Value	Dimensions orientation
Height	Core RRH: 336 mm (13.2 in.) With upper and lower mounting brackets: 427.5 mm (16.8 in.)	
Width	295 mm (11.6 in.)	
Depth	Core RRH: 100 mm (3.9 in.) With mounting brackets: 124 mm (4.9 in.)	
Weight	11 kg (24.2 lb)	
Volume	Without ID Cover: 10 l	

Environmental specifications

Table 134 AHGC environmental specifications

Property	Value
Maximum operational outdoor temperature (stand-alone outdoor pole or mast)	55°C (131°F)
Maximum operational indoor and outdoor temperature (wall and shelter)	45°C (113°F)
Minimum operational temperature	-40°C (-40°F)
IP rating	IP65

LTE4510 feature interdependencies

The *LTE4510:AirScale RRH 2T4R B1 120W (AHGC)* feature is impacted by the following features:

- *LTE112: Cell Bandwidth - 20 MHz*
Needs to be enabled to use LTE 20 MHz carriers.
- *LTE113: Cell Bandwidth - 15 MHz*
Needs to be enabled to use LTE 15 MHz carriers.
- *LTE114: Cell Bandwidth - 10 MHz*
Needs to be enabled to use LTE 10 MHz carriers.
- *LTE115: Cell Bandwidth - 5 MHz*
Needs to be enabled to use LTE 5 MHz carriers.
- With *LTE614: Distributed Site*,
AHPC can be used in distributed sites with up to 23 km fiber length to the system module.
- *LTE1103: Load based Power Saving for multi-layer networks*
Needs to be enabled to use Load based Power Saving for multi-layer networks.
- *LTE1203: Load based Power Saving with Tx path switching off*
Needs to be enabled to use Load based Power Saving with Tx path switching off.
- *LTE2508: BTS Embedded Power Meter for Energy Efficiency Monitoring*
Needs to be enabled to use BTS Embedded Power Meter for Energy Efficiency Monitoring.
- *LTE2541: Nokia CPRI RRH/RFM chaining*
Provides support for chaining.
- *LTE3036: Micro DTX extension*
Needs to be enabled to use Micro DTX extension.

5.2.9 Nokia AirScale RRH 2T4R B3 160 W (AHEC)

AHEC is introduced by LTE3087/SR001389: Nokia AirScale RRH 2T4R B3 160 W (AHEC).

Functional description

Table 135 AHEC functional specification

Property	Value
Output power	2x80 W
QAM	256 QAM (DL) 64 QAM (UL)
Number of TXRX	2T4R
Outdoor installation	Yes
Supported technologies (standalone and MSR)	GSM, FDD-LTE, 5G-ready GSM-LTE
IoT support	NB-IoT in band, guard band (GB), standalone (SA)

Table 135 AHEC functional specification (Cont.)

Property	Value
TX frequency range	1805 - 1860 MHz
RX frequency range	1710 - 1765 MHz
DL filter bandwidth	55 MHz
UL filter bandwidth	55 MHz
iBW (instantaneous bandwidth)	55 MHz
oBW (occupied bandwidth)	55 MHz
Number of carriers per pipe	Up to 6
Supported bandwidths	1.4, 3, 5, 10, 15, 20 MHz
PIM cancellation	Yes
MSR Mode support from SRAN 18SP onwards	LTE, LTE-GSM

Interfaces

Figure 36 AHEC interfaces

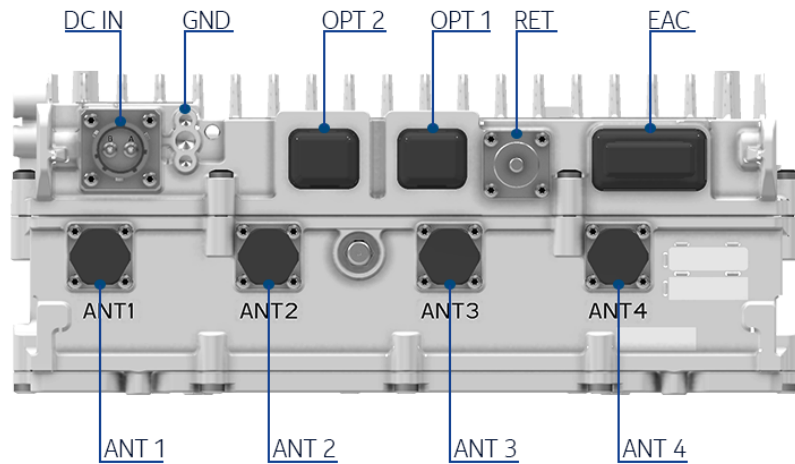

Table 136 AHEC interfaces

Interface	Label on the HW	Number of interfaces	Connector type	Additional info
Power Connector	DC IN	1	Low power circular	APPA, APPB, APPC
Antenna connector	ANT	4	4.3-10	-
Remote Electrical Tilt	RET	1	8-pin circular	RS-485

Table 136 AHEC interfaces (Cont.)

Interface	Label on the HW	Number of interfaces	Connector type	Additional info
Optical interface	SFP	2	SFP+	9.8 Gbps, CPRI; Nokia IP seal
External Alarm Connection	EAC	1	MDR26	4 alarm inputs and 1 control output
Grounding	GND	1	M8 or dual M5 screws	-



WARNING! Risk of electric shock

Before turning RF power on, RF ports have to be terminated by nominal 50 Ω load (for example, feeder with antenna). However, if these conditions are not met, the plastic caps that are delivered within the unused RF ports should remain in place. The plastic caps isolate RF port from the environment, and thus provide electric shock security in case RF power is accidentally on.

Antenna Line Devices (ALDs) support

Table 137 AHEC ALD support

ALD support through RS485/8-pin circular ports	Value
AISG	RET: AISG 2.0/3.0
CWA (for non-AISG installations)	No
Voltage	RET: 14.5 V
Power per port	40 W

Functional block diagram

Figure 37 AHEC functional block diagram

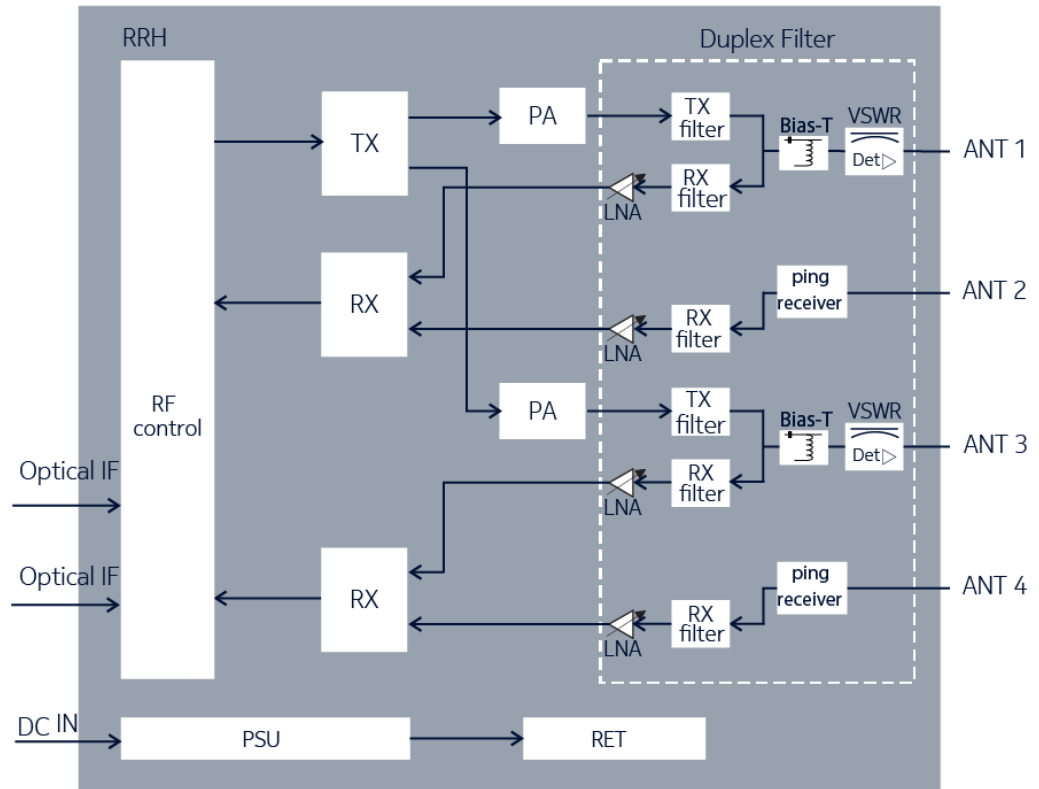

Electrical specifications

Table 138 AHEC electrical specifications

Property	Value
Nominal supply voltage	-48.0 V DC
Nominal input voltage range	-40.5 V DC to -57.0 V DC
Extended input voltage range	-36.0 V DC to -40.5 V DC -57.0 V DC to -60.0 V DC



Note: The minimum start-up voltage is -40.5 V DC. If the input voltage is below/beyond the extended limits, the unit might shut down.

Power consumption

Typical power consumption [W] for 48VDC input, at 25°C, representative of typical product performance under the same conditions (HW variant, SW version, configuration, environment, and so on) with +/- 10% margin. Average = (6h low hour load, 10h medium hour load and 8h busy hour load) / 24h

Configurations explained on examples:

- GSM/WCDMA: 2/2/2 = three sectors, two carriers/TRXs per sector
- LTE:
 - o 2/2/2 2Tx = three sectors, two carriers per sector, 2Tx per carrier

o 1+1/1+1/1+1 4Tx = three dual-band sectors, one carrier per sector per band, 4Tx per carrier

Some radio units are capable of providing only one sector coverage. Then the power values in the table consider deployment of three radio units.

Table 139 AHEC power consumption in LTE mode

Configuration	Output Power per carrier (W)	Power consumption (W), ETSI 202706 average load $P_{RRH, static}$	Power consumption (W), ETSI 202706 busy hour load $P_{BH, RRH, static}$	Power consumption (W), 100% RF power load $P_{100\% RRH}$
1/1/1 2Tx	2x80	821	1044	1612
1/1/1 2Tx	2x60	734	904	1306
1/1/1 2Tx	2x40	639	756	1006
1/1/1 2Tx	2x30	593	686	878
1/1/1 2Tx	2x20	542	609	742

Power reduction



Note: The maximum power reduction (`dlCellPwrRed`) value is 20 dB. High power reduction values may cause radio outages.

Related optional items

- APAA AirScale AC-DC Power Unit 760W (473936A)
- AMAA AirScale 2 casing for RRH aux-units (474141A):
 - APAC AirScale AC PDU 1 to 3 (474142A)
 - APAA AirScale AC-DC Power Unit 760W (473936A) - maximum three units per one AMAA
- AMGC AirScale 2 cover 300 x 101-125 (474269A)
- AMBF AirScale book mount kit 126-150 (474278A)
- FPKA Flexi Pole Mounting Kit (30-120 mm) (471649A)
- FPKC Flexi Pole Mounting Kit (60-300 mm) (472821A)
- AMPA Pole Mounting Kit (30-120 mm) (473879A)
- AMFA AirScale 2 FPKx fixing adapter (474289A)
- AMFN AirScale 2 casing adapter RRH 300 (474664A)
- AMRA AirScale one clip bracket 51-125 (474580A)
- AMRC AirScale one clip rail 600 mm (474583A)
- ASAA AirScale 2 MDR26-open EAC cable 5 m (474288A)
- APPA AirScale 2 26A DC plug 3.3-10 mm² (474281A)

Installation options

- Pole mounting, vertical
- Wall mounting, vertical
- Compatible to RAS mounting, vertical
- Bookshelf mounting

Dimensions and weight

Table 140 AHEC dimensions and weight

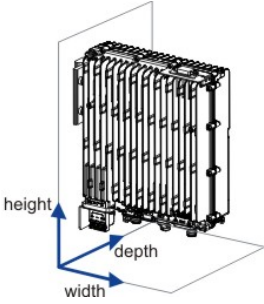
Property	Value	Dimensions orientation
Height	Core RRH: 336 mm (13.2 in.) With upper and lower mounting brackets: 427.5 mm (16.8 in.)	
Width	308 mm (12.1 in.)	
Depth	Core RRH: 125 mm (4.9 in.) With mounting brackets: 149 mm (5.8 in.)	
Weight	max. 12.8 kg (28.2 lb)	
Volume	Without ID Cover: 12.9 l	

Environmental specifications

Table 141 AHEC environmental specifications

Property	Value
Maximum operational outdoor temperature (in the shade)	55°C (131°F)
Maximum operational outdoor temperature (in the sun)	55°C (131°F)
Maximum indoor temperature	45°C (113°F)
Minimum operational temperature	-40°C (-40°F)
IP rating	IP65

LTE3087 feature interdependencies

The *LTE3087: Nokia AirScale RRH 2T4R B3 160W (AHEC)* feature is impacted by the following features:

- *LTE112: Cell Bandwidth - 20 MHz*
Needs to be enabled to use LTE 20 MHz carriers.
- *LTE113: Cell Bandwidth - 15 MHz*
Needs to be enabled to use LTE 15 MHz carriers.
- *LTE114: Cell Bandwidth - 10 MHz*
Needs to be enabled to use LTE 10 MHz carriers.
- *LTE115: Cell Bandwidth - 5 MHz*
Needs to be enabled to use LTE 5 MHz carriers.
- *LTE116: Cell Bandwidth - 3 MHz*
Needs to be enabled to use LTE 3 MHz carriers.
- *LTE117: Cell Bandwidth - 1.4 MHz*
needs to be enabled to use LTE 1.4 MHz carriers.
- With *LTE614: Distributed Site*,
AHEC can be used in distributed sites with up to 23km fiber length to the system module.

- *LTE1103: Load based Power Saving for multi-layer networks*
Needs to be enabled to use Load based Power Saving for multi-layer networks.
- *LTE1203: Load based Power Saving with TX path switching off*
Needs to be enabled to use Load based Power Saving with TX path switching off.
- *LTE2508: BTS Embedded Power Meter for Energy Efficiency Monitoring*
Needs to be enabled to use BTS Embedded Power Meter for Energy Efficiency Monitoring.
- With *LTE2541: Nokia CPRI RRH/RFM chaining*,
AHEC supports Nokia CPRI chain of up to 4 radio units.
- With *LTE2553: OBSAI chaining to 9.8G CPRI link*,
AHEC supports chaining of legacy OBSAI radio units with Nokia CPRI radio modules.
- *LTE3036: Micro DTX extension*
Needs to be enabled to use Micro DTX extension.

5.2.10 Nokia AirScale RRH 2T4R B3 160 W (AHED)

AHED is introduced by LTE3130/SR001415: Nokia AirScale RRH 2T4R B3 160W (AHED).

Functional description

Table 142 AHED functional specification

Property	Value
Output power	2x80 W
QAM	256 QAM (DL) 64 QAM (UL)
Number of TXRX	2T4R
Outdoor installation	Yes
Supported technologies (standalone and MSR)	GSM, FDD-LTE, 5G-ready LTE-GSM
IoT support	NB-IoT in band, guard band (GB), standalone (SA)
TX frequency range	1825 - 1880 MHz
RX frequency range	1730 - 1785 MHz
DL filter bandwidth	55 MHz
UL filter bandwidth	55 MHz
iBW (instantaneous bandwidth)	55 MHz
oBW (occupied bandwidth)	55 MHz
Number of carriers per pipe	Up to 6
Supported bandwidths	1.4, 3, 5, 10, 15, 20 MHz
PIM cancellation	Yes

Interfaces

Figure 38 AHED interfaces

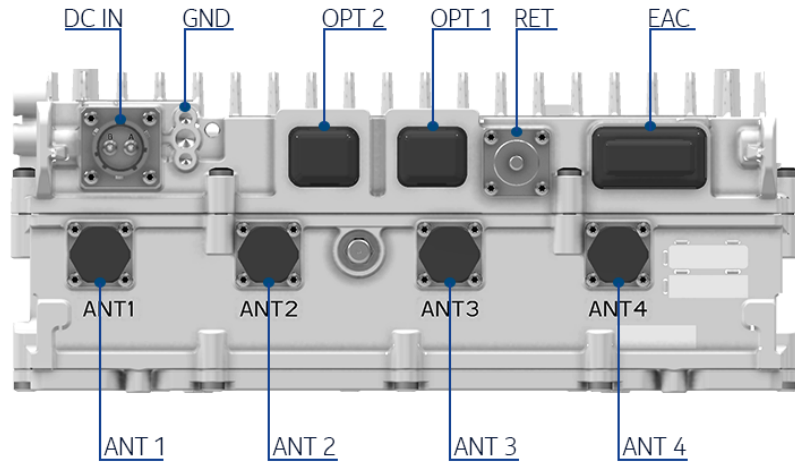

Table 143 AHED interfaces

Interface	Label on the HW	Number of interfaces	Connector type	Additional info
Power Connector	DC IN	1	Low power circular	APPA, APPB, APPC
Antenna connector	ANT	4	4.3-10	-
Remote Electrical Tilt	RET	1	8-pin circular	RS-485
Optical interface	SFP	2	SFP+	9.8 Gbps, CPRI; Nokia IP seal
External Alarm Connection	EAC	1	MDR26	4 alarm inputs and 1 control output
Grounding	GND	1	M8 or dual M5 screws	-



WARNING! Risk of electric shock

Before turning RF power on, RF ports have to be terminated by nominal 50 Ω load (for example, feeder with antenna). However, if these conditions are not met, the plastic caps that are delivered within the unused RF ports should remain in place. The plastic caps isolate RF port from the environment, and thus provide electric shock security in case RF power is accidentally on.

Antenna Line Devices (ALDs) support

Table 144 AHED ALD support

ALD support through RS485/8-pin circular ports	Value
AISG	RET: AISG 2.0/3.0
CWA (for non-AISG installations)	No
Voltage	RET: 14.5 V
Power per port	45 W

Functional block diagram

Figure 39 AHED functional block diagram

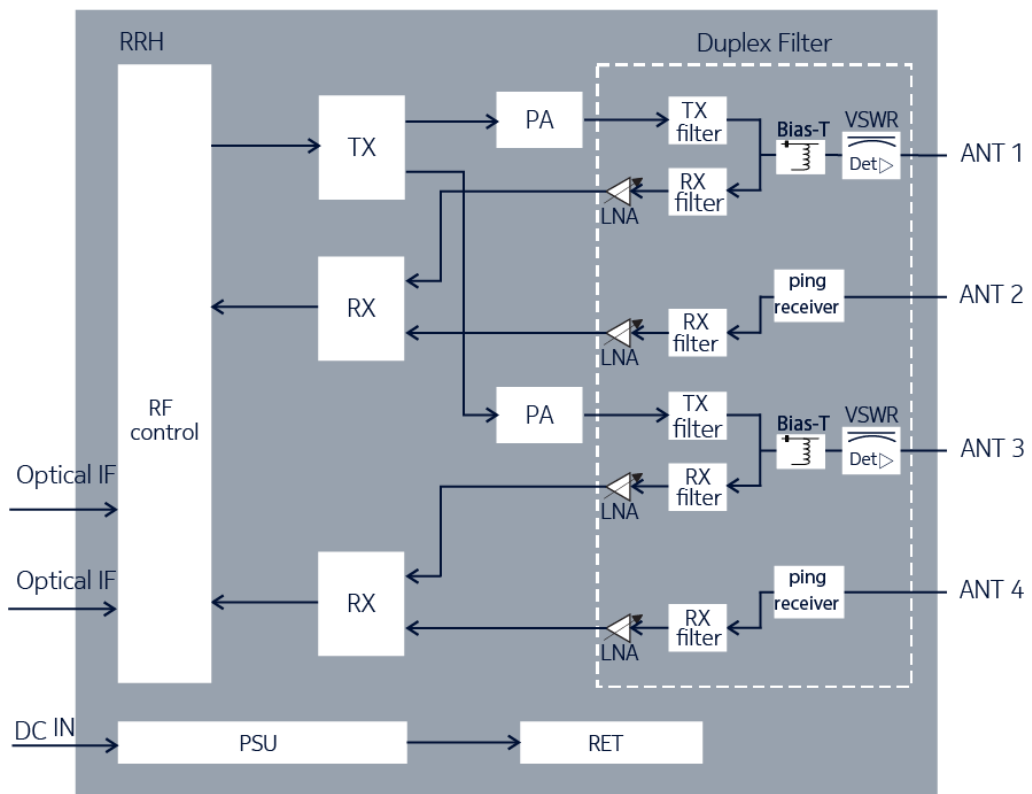

Electrical specifications

Table 145 AHED electrical specifications

Property	Value
Nominal supply voltage	-48.0 V DC
Nominal input voltage range	-40.5 V DC to -57.0 V DC
Extended input voltage range	-36.0 V DC to -40.5 V DC -57.0 V DC to -60.0 V DC



Note: The minimum start-up voltage is -40.5 V DC. If the input voltage is below/beyond the extended limits, the unit might shut down.

Power consumption

Typical power consumption [W] for 48VDC input, at 25°C, representative of typical product performance under the same conditions (HW variant, SW version, configuration, environment, and so on) with +/- 10% margin. Average = (6h low hour load, 10h medium hour load and 8h busy hour load) / 24h

Configurations explained on examples:

- GSM/WCDMA: 2/2/2 = three sectors, two carriers/TRXs per sector
- LTE:
 - o 2/2/2 2Tx = three sectors, two carriers per sector, 2Tx per carrier
 - o 1+1/1+1/1+1 4Tx = three dual-band sectors, one carrier per sector per band, 4Tx per carrier

Some radio units are capable of providing only one sector coverage. Then the power values in the table consider deployment of three radio units.

Table 146 AHED power consumption in LTE mode

Configuration	Output power per carrier [W]	Power consumption ETSI 202706 average P_{RRH} , static	Power consumption ETSI 202706 busy hour load $P_{BH\ RRH}$, static	Power consumption 100% RF power load $P_{100\% \ RRH}$
1/1/1 2Tx	2x80	830	1066	1654
1/1/1 2Tx	2x60	744	930	1352
1/1/1 2Tx	2x40	638	761	1018
1/1/1 2Tx	2x30	592	692	888
1/1/1 2Tx	2x20	536	610	746

Power reduction



Note: The maximum power reduction (`dlCellPwrRed`) value is 20 dB. High power reduction values may cause radio outages.

Related optional items

- APAA AirScale AC-DC Power Unit 760W (473936A)
- AMAA AirScale 2 casing for RRH aux-units (474141A):
 - APAC AirScale AC PDU 1 to 3 (474142A)
 - APAA AirScale AC-DC Power Unit 760W (473936A) - maximum three units per one AMAA
- AMGC AirScale 2 cover 300 x 101-125 (474269A)
- AMBF AirScale book mount kit 126-150 (474278A)
- FPKA Flexi Pole Mounting Kit (30-120 mm) (471649A)
- FPKC Flexi Pole Mounting Kit (60-300 mm) (472821A)
- AMPA Pole Mounting Kit (30-120 mm) (473879A)
- AMFA AirScale 2 FPKx fixing adapter (474289A)
- AMFN AirScale 2 casing adapter RRH 300 (474664A)

- AMRA AirScale one clip bracket 51-125 (474580A)
- AMRC AirScale one clip rail 600 mm (474583A)
- ASAA AirScale 2 MDR26-open EAC cable 5 m (474288A)
- APPA AirScale 2 26A DC plug 3.3-10 mm² (474281A)
- APPB AirScale 2 55A DC plug 3.3-10 mm² (474282A)
- APPC AirScale 2 55A DC plug 10-16 mm² (474283A)

Installation options

- pole mounting, vertical
- wall mounting, vertical
- compatible to RAS mounting, vertical
- bookshelf mounting

Dimensions and weight

Table 147 AHED dimensions and weight

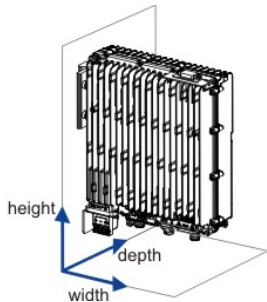
Property	Value	Dimensions orientation
Height	Core RRH: 336 mm (13.2 in.) With upper and lower mounting brackets: 427.5 mm (16.8 in.)	
Width	308 mm (12.1 in.)	
Depth	Core RRH: 125 mm (4.9 in.) With mounting brackets: 149 mm (5.8 in.)	
Weight	max. 12.8 kg (28.2 lb)	
Volume	Without ID Cover: 12.9 l	

Environmental specifications

Table 148 AHED environmental specifications

Property	Value
Maximum operational outdoor temperature (in the shade)	55°C (131°F)
Maximum operational outdoor temperature (in the sun)	55°C (131°F)
Maximum indoor temperature	45°C (113°F)
Minimum operational temperature	-40°C (-40°F)
IP rating	IP65

LTE3130 feature interdependencies

The LTE3130: Nokia AirScale RRH 2T4R B3 160W feature is impacted by the following features:

- *LTE112: Cell Bandwidth - 20 MHz*
needs to be enabled to use LTE 20 MHz carriers.
- *LTE113: Cell Bandwidth - 15 MHz*
needs to be enabled to use LTE 15 MHz carriers.
- *LTE114: Cell Bandwidth - 10 MHz*
needs to be enabled to use LTE 10 MHz carriers.
- *LTE115: Cell Bandwidth - 5 MHz*
needs to be enabled to use LTE 5 MHz carriers.
- *LTE116: Cell Bandwidth - 3 MHz*
needs to be enabled to use LTE 3 MHz carriers.
- *LTE117: Cell Bandwidth - 1.4 MHz*
needs to be enabled to use LTE 1.4 MHz carriers.
- With *LTE614: Distributed Site*,
AHED can be used in distributed sites with up to 23km fiber length to the system module.
- *LTE1103: Load based Power Saving for multi-layer networks*
needs to be enabled to use Load based Power Saving for multi-layer networks.
- *LTE1203: Load based Power Saving with Tx path switching off*
needs to be enabled to use Load based Power Saving with Tx path switching off.
- *LTE2508: BTS Embedded Power Meter for Energy Efficiency Monitoring*
needs to be enabled to use BTS Embedded Power Meter for Energy Efficiency Monitoring.
- With *LTE2541: Nokia CPRI RRH/RFM chaining*,
AHED supports Nokia CPRI chain of up to 4 radio units.
- *LTE3036: Micro DTX extension*
needs to be enabled to use Micro DTX extension.

5.2.11 Nokia AirScale RRH 2T4R B8 120 W (AHDA)

AHDA is introduced by LTE3678/SR001667: Nokia AirScale RRH 2T4R B8 120 W (AHDA).

Functional description

Table 149 AHDA functional specification

Property	Value
Output power	2x60 W
QAM modulation	256 QAM (DL) 64 QAM (UL)
Number of TXRX	2T4R
Outdoor installation	Yes
Supported technologies (standalone and MSR)	GSM, WCDMA, FDD-LTE, 5G-ready GSM-WCDMA, WCDMA-LTE, GSM-LTE, GSM-WCDMA-LTE

Table 149 AHDA functional specification (Cont.)

Property	Value
IoT support	NB-IoT in band, guard band (GB), standalone (SA)
TX frequency range	925 MHz - 960 MHz
RX frequency range	880 MHz - 915 MHz
DL filter bandwidth	35 MHz
UL filter bandwidth	35 MHz
iBW (instantaneous bandwidth)	35 MHz
oBW (occupied bandwidth)	35 MHz
Number of carriers per pipe	Up to 8
Supported bandwidths	1.4, 3, 5, 10 MHz
PIM cancellation	Yes

Interfaces

Figure 40 AHDA interfaces

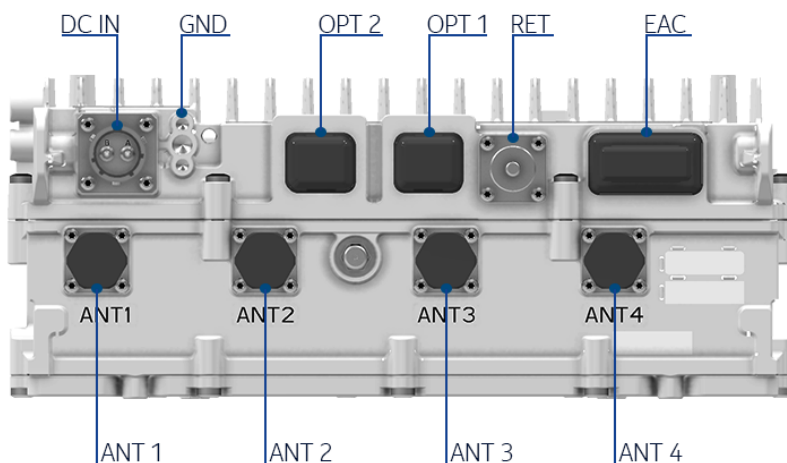

Table 150 AHDA interfaces

Interface	Label on the HW	Number of interfaces	Connector type	Additional info
Power Connector	DC IN	1	Low power circular	APPA, APPB, APPC
Antenna connector	ANT	4	4.3-10	-

Table 150 AHDA interfaces (Cont.)

Interface	Label on the HW	Number of interfaces	Connector type	Additional info
Remote Electrical Tilt	RET	1	8-pin circular	RS-485
Optical interface	SFP	2	SFP+	9.8 Gbps, CPRI; Nokia IP seal
External Alarm Connection	EAC	1	MDR26	4 alarm inputs and 1 control output
Grounding	GND	1	M8 or dual M5 screws	-
Fan	FAN	1	Nokia fan	Located on the opposite side



WARNING! Risk of electric shock

Before turning RF power on, RF ports have to be terminated by nominal 50 Ω load (for example, feeder with antenna). However, if these conditions are not met, the plastic caps that are delivered within the unused RF ports should remain in place. The plastic caps isolate RF port from the environment, and thus provide electric shock security in case RF power is accidentally on.

Antenna Line Devices (ALDs) support

Table 151 AHDA ALD support

ALD support	Value
AISG	ANT1, ANT3: AISG 2.0/3.0 ANT2, ANT4: AISG 3.0 ping receiver RET: AISG 2.0/3.0
Voltage	ANT1, ANT3, RET: 14.5 V
Power per port	30 W, 45 W total

Functional block diagram

Figure 41 AHDA functional block diagram

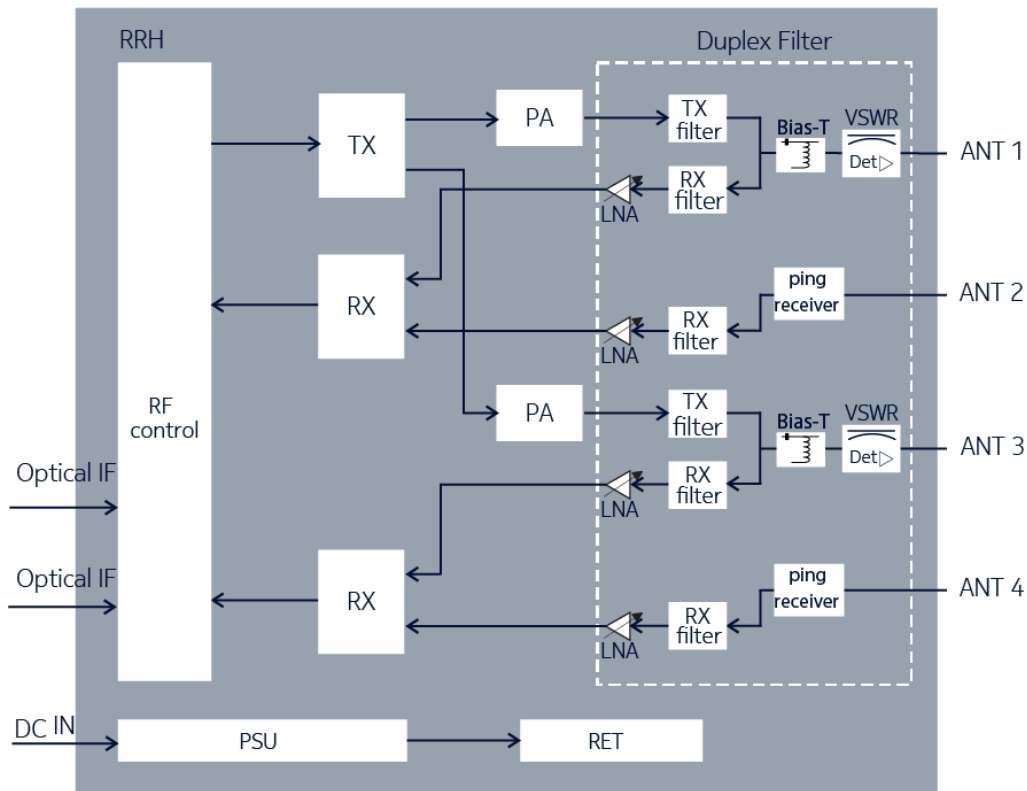

Electrical specifications

Table 152 AHDA electrical specifications

Property	Value
Nominal supply voltage	-48.0 V DC
Nominal input voltage range	-40.5 V DC to -57.0 V DC
Extended input voltage range	-36.0 V DC to -40.5 V DC -57.0 V DC to -60.0 V DC



Note: The minimum start-up voltage is -40.5 V DC. If the input voltage is below/beyond the extended limits, the unit might shut down.

Power consumption

Typical power consumption [W] for 48VDC input, at 25°C, representative of typical product performance under the same conditions (HW variant, SW version, configuration, environment, and so on) with +/- 10% margin. Average = (6h low hour load, 10h medium hour load and 8h busy hour load) / 24h

Configurations explained on examples:

- GSM/WCDMA: 2/2/2 = three sectors, two carriers/TRXs per sector
- LTE:
 - o 2/2/2 2Tx = three sectors, two carriers per sector, 2Tx per carrier

o 1+1/1+1/1+1 4Tx = three dual-band sectors, one carrier per sector per band, 4Tx per carrier

Some radio units are capable of providing only one sector coverage. Then the power values in the table consider deployment of three radio units.

Table 153 AHDA power consumption in LTE mode

Configuration	Output Power per carrier (W)	Power consumption (W), ETSI 202706 average load $P_{RRH, static}$	Power consumption (W), ETSI 202706 busy hour load $P_{BH, RRH, static}$	Power consumption (W), 100% RF power load $P_{100\% RRH}$
1/1/1 2Tx	2x60	773	923	1279
1/1/1 2Tx	2x40	690	793	1011
1/1/1 2Tx	2x30	649	731	894
1/1/1 2Tx	2x20	564	620	728

Power reduction

Table 154 AHDA power reduction

Single carrier LTE 256 QAM [dB]	64 QAM LTE + GSM [dB]
0	0.3



Note: The maximum power reduction (`dlCellPwrRed`) value is 20 dB. High power reduction values may cause radio outages.

Related optional items

- ASFA AirScale 2 fan unit 300 (473968A)
- APAA AirScale AC-DC Power Unit 760W (473936A)
- AMAA AirScale 2 casing for RRH aux-units (474141A):
 - APAC AirScale AC PDU 1 to 3 (474142A)
 - APAA AirScale AC-DC Power Unit 760W (473936A) - maximum three units per one AMAA
- AMGD AirScale 2 cover 300 x 126-150 (474270A)
- AMBF AirScale book mount kit 126-150 (474278A) ¹⁾
- FPKA Flexi Pole Mounting Kit (30-120 mm) (471649A)
- FPKC Flexi Pole Mounting Kit (60-300 mm) (472821A)
- AMPA Pole Mounting Kit (30-120 mm) (473879A)
- AMFA AirScale 2 FPKx fixing adapter (474289A)
- AMFN AirScale 2 casing adapter RRH 300 (474664A)
- AMRA AirScale one clip bracket 51-125 (474580A)
- AMRC AirScale one clip rail 600 mm (474583A)
- ASAA AirScale 2 MDR26-open EAC cable 5 m (474288A)
- APPA AirScale 2 26A DC plug 3.3-10 mm² (474281A)
- APPB AirScale 2 55A DC plug 3.3-10 mm² (474282A)

¹⁾ Not fully verified.

- APPC AirScale 2 55A DC plug 10-16 mm² (474283A)
- ACPA AirScale 2 Fiber Protection (474297A)

Installation options

- Pole mounting: vertical, horizontal with optional fan
- Wall mounting: vertical, horizontal with optional fan
- Compatible to RAS mounting: vertical
- Book mounting



NOTICE: Install this RRH in a vertical orientation with connectors on the bottom side, to ensure convection cooling. For horizontal installation fans are required.

Dimensions and weight

Table 155 AHDA dimensions and weight

Property	Value	Dimensions orientation
Height	Core RRH: 336 mm (13.25 in.) With mounting brackets: 428 mm (16.87 in.)	
Width	309 mm (12.17 in.)	
Depth	Core RRH: 130 mm (5.12 in.) With mounting brackets: 153 mm (6.02 in.)	
Volume	13.6 l	
Weight	14.0 kg (30.9 lbs)	

Environmental specifications

Table 156 AHDA environmental specifications

Property	Value
Maximum operational outdoor temperature (in the shade)	55°C (131°F)
Maximum operational outdoor temperature (in the sun)	55°C (131°F)
Maximum indoor temperature	45°C (113°F)
Minimum operational temperature	-40°C (-40°F)
IP rating	IP65

LTE3678 feature interdependencies

The *LTE3678: AirScale RRH 2T4R B8 120W AHDA* feature is impacted by the following features:

- *LTE114: Cell Bandwidth - 10 MHz* enables the use of LTE 10 MHz carriers.
- *LTE115: Cell Bandwidth - 5 MHz* enables the use of LTE 5 MHz carriers.

- *LTE116: Cell Bandwidth - 3 MHz* enables the use of LTE 3 MHz carriers.
- *LTE117: Cell Bandwidth - 1.4 MHz* enables the use of LTE 1.4 MHz carriers.
- With *LTE614: Distributed Site*, AHDA can be used in distributed sites with up to 23 km fiber length to the system module.
- *LTE1103: Load based Power Saving for multi-layer networks* enables the use of Load based Power Saving for multi-layer networks.
- *LTE1203: Load based Power Saving with Tx path switching off* enables the use of Load based Power Saving with Tx path switching off.
- *LTE2508: BTS Embedded Power Meter for Energy Efficiency Monitoring* enables the use of BTS Embedded Power Meter for Energy Efficiency Monitoring.
- *LTE2541: Nokia CPRI RRH/RFM chaining* provides support for chaining.
- *LTE3036: Micro DTX extension* enables the use of Micro DTX extension.

5.2.12 Nokia AirScale RRH 2T4R B8/n8 160 W (AHDB)

AHDB is introduced by LTE3837, SR001753, 5GC000729: Nokia AirScale RRH 2T4R B8/n8 160 W (AHDB).

Functional description

Table 157 AHDB functional specification

Property	Value
Output power	2x80 W
QAM	256 QAM (DL) 64 QAM (UL)
Number of TXRX	2T4R
Outdoor installation	Yes
Supported technologies (standalone and MSR)	GSM, WCDMA, FDD-LTE, 5G-ready GSM-WCDMA, WCDMA-LTE, GSM-LTE, GSM-WCDMA-LTE
IoT support	NB-IoT in band, guard band (GB), standalone (SA)
TX frequency range	934 - 960 MHz
RX frequency range	889 - 915 MHz
DL filter bandwidth	26 MHz
UL filter bandwidth	26 MHz
iBW (instantaneous bandwidth)	26 MHz
oBW (occupied bandwidth)	26 MHz
Number of carriers per pipe	Up to 8 carriers in total for all supported RATs
Supported bandwidths	LTE: 1.4, 3, 5, 10 MHz 5G: 5, 10, 15, 20 MHz
PIM cancellation	Yes

Interfaces

Figure 42 AHDB interfaces

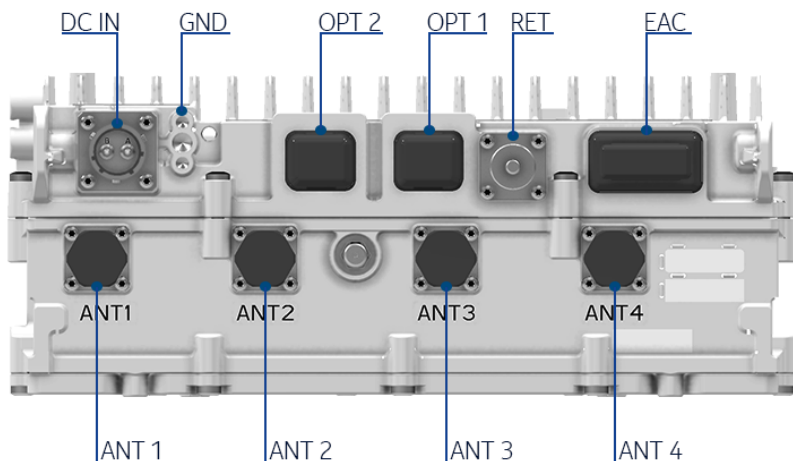

Table 158 AHDB interfaces

Interface	Label on the HW	Number of interfaces	Connector type	Additional info
Power Connector	DC IN	1	Low power circular	APPA, APPB, APPC
Antenna connector	ANT	4	4.3-10	-
Remote Electrical Tilt	RET	1	8-pin circular	RS-485
Optical interface	SFP	2	SFP+	9.8 Gbps, CPRI; Nokia IP seal
External Alarm Connection	EAC	1	MDR26	4 alarm inputs and 1 control output
Grounding	GND	1	M8 or dual M5 screws	-



WARNING! Risk of electric shock

Before turning RF power on, RF ports have to be terminated by nominal 50 Ω load (for example, feeder with antenna). However, if these conditions are not met, the plastic caps that are delivered within the unused RF ports should remain in place. The plastic caps isolate RF port from the environment, and thus provide electric shock security in case RF power is accidentally on.

Antenna Line Devices (ALDs) support

Table 159 AHDB ALD support

ALD support through RS485/8-pin circular ports	Value
AISG	RET: AISG 2.0/3.0
Proprietary AISG1.1	No
CWA (for non-AISG installations)	No
Voltage	RET: 14.5 V
Power per port	45 W

Functional block diagram

Figure 43 AHDB functional block diagram

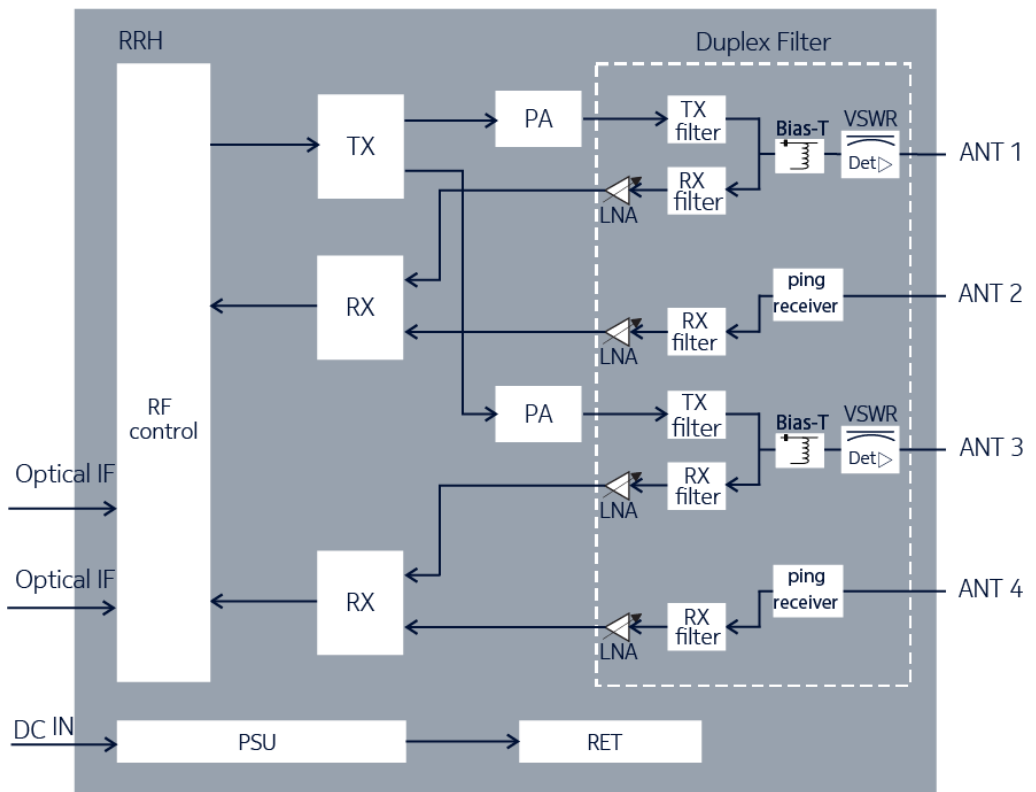

Electrical specifications

Table 160 AHDB electrical specifications

Property	Value
Nominal supply voltage	-48.0 V DC
Nominal input voltage range	-40.5 V DC to -57.0 V DC
Extended input voltage range	-36.0 V DC to -40.5 V DC -57.0 V DC to -60.0 V DC



Note: The minimum start-up voltage is –40.5 V DC. If the input voltage is below/beyond the extended limits, the unit might shut down.

Power consumption

Typical power consumption [W] for 48VDC input, at 25°C, representative of typical product performance under the same conditions (HW variant, SW version, configuration, environment, and so on) with +/- 10% margin. Average = (6h low hour load, 10h medium hour load and 8h busy hour load) / 24h

Configurations explained on examples:

- GSM/WCDMA: 2/2/2 = three sectors, two carriers/TRXs per sector
- LTE:
 - o 2/2/2 2Tx = three sectors, two carriers per sector, 2Tx per carrier
 - o 1+1/1+1/1+1 4Tx = three dual-band sectors, one carrier per sector per band, 4Tx per carrier

Some radio units are capable of providing only one sector coverage. Then the power values in the table consider deployment of three radio units.

Table 161 AHDB power consumption in LTE mode

Configuration	Output power per carrier [W]	Power consumption ETSI 202706 average P _{RRH} , static	Power consumption ETSI 202706 busy hour load P _{BH RRH, static}	Power consumption 100% RF power load P _{100% RRH}
1/1/1 2Tx	2x80	805	990	1470
1/1/1 2Tx	2x60	737	882	1223
1/1/1 2Tx	2x40	656	755	968
1/1/1 2Tx	2x30	616	695	852
1/1/1 2Tx	2x20	573	628	735

Power reduction



Note: The maximum power reduction (dlCellPwrRed) value is 20 dB. High power reduction values may cause radio outages.

Related optional items

- APAA AirScale AC-DC Power Unit 760W (473936A)
- AMAA AirScale 2 casing for RRH aux-units (474141A):
 - APAC AirScale AC PDU 1 to 3 (474142A)
 - APAA AirScale AC-DC Power Unit 760W (473936A) - maximum three units per one AMAA
- AMGC AirScale 2 cover 300 x 101-125 (474269A)
- AMBF AirScale book mount kit 126-150 (474278A)
- FPKA Flexi Pole Mounting Kit (30-120 mm) (471649A)
- FPKC Flexi Pole Mounting Kit (60-300 mm) (472821A)

- AMPA Pole Mounting Kit (30-120 mm) (473879A)
- AMFA AirScale 2 FPKx fixing adapter (474289A)
- AMFN AirScale 2 casing adapter RRH 300 (474664A)
- AMRA AirScale one clip bracket 51-125 (474580A)
- AMRC AirScale one clip rail 600 mm (474583A)
- ASAA AirScale 2 MDR26-open EAC cable 5 m (474288A)
- APPA AirScale 2 26A DC plug 3.3-10 mm² (474281A)
- APPB AirScale 2 55A DC plug 3.3-10 mm² (474282A)
- APPC AirScale 2 55A DC plug 10-16 mm² (474283A)

Installation options

- Pole mounting, vertical
- Wall mounting, vertical
- Compatible to RAS mounting , vertical
- Bookshelf mounting

Dimensions and weight

Table 162 AHDB dimensions and weight

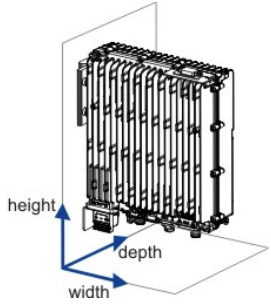
Property	Value	Dimensions orientation
Height	Core RRH: 336 mm (13.25 in.) With mounting brackets: 428 mm (16.87 in.)	
Width	309 mm (12.17 in.)	
Depth	Core RRH: 125 mm (4.92 in.) With mounting brackets: 149 mm (5.86 in.)	
Weight	max. 12.8 kg (28.2 lb)	
Volume	Without ID Cover: 12.2 l	

Environmental specifications

Table 163 AHDB environmental specifications

Property	Value
Maximum operational outdoor temperature (stand-alone outdoor pole or mast)	55°C (131°F)
Maximum operational indoor and outdoor temperature (wall and shelter)	45°C (113°F)
Minimum operational temperature	-40°C (-40°F)
IP rating	IP65

LTE3837 interdependencies between features

The *LTE3837: Nokia AirScale RRH 2T4R B8 160 W* feature supports the following features:

- *LTE114: Cell Bandwidth - 10 MHz*
needs to be enabled to use LTE 10 MHz carriers.
- *LTE115: Cell Bandwidth - 5 MHz*
needs to be enabled to use LTE 5 MHz carriers.
- *LTE116: Cell Bandwidth - 3 MHz*
needs to be enabled to use LTE 3 MHz carriers.
- *LTE117: Cell Bandwidth - 1.4 MHz*
needs to be enabled to use LTE 1.4 MHz carriers.
- With *LTE614: Distributed Site*,
AHDB can be used in distributed sites with up to 23 km fiber length to the system module.
- *LTE1103: Load based Power Saving for multi-layer networks*
needs to be enabled to use Load based Power Saving for multi-layer networks.
- *LTE1203: Load based Power Saving with Tx path switching off*
needs to be enabled to use Load based Power Saving with Tx path switching off.
- *LTE2508: BTS Embedded Power Meter for Energy Efficiency Monitoring*
needs to be enabled to use BTS Embedded Power Meter for Energy Efficiency Monitoring.
- *LTE2541: Nokia CPRI RRH/RFM chaining*
Provides support for chaining.
- *LTE3036: Micro DTX extension*
needs to be enabled to use Micro DTX extension.

5.2.13 Nokia AirScale RRH 2T4R B20 120 W (AHMA)

AHMA is introduced by *LTE4118: Nokia AirScale RRH 2T4R B20 120 W (AHMA)*.

Functional description

Table 164 AHMA functional specification

Property	Value
Output power	2x60 W
QAM	256 QAM (DL) 64 QAM (UL)
Number of TXRX	2T4R
Outdoor installation	Yes
Supported technologies (standalone and MSR)	FDD-LTE, 5G-ready
IoT support	NB-IoT in band, guard band (GB), standalone (SA)
TX frequency range	791 - 821 MHz
RX frequency range	832 - 862 MHz
DL filter bandwidth	30 MHz

Table 164 AHMA functional specification (Cont.)

Property	Value
UL filter bandwidth	30 MHz
iBW (instantaneous bandwidth)	30 MHz
oBW (occupied bandwidth)	30 MHz
Number of carriers per pipe	Up to 3
Supported bandwidths	5, 10, 15, 20 MHz
PIM cancellation	Yes

Interfaces

Figure 44 AHMA interfaces

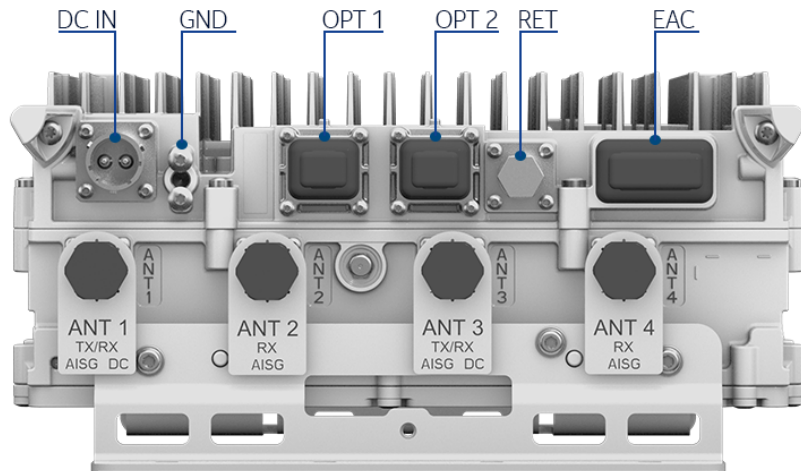



Table 165 AHMA interfaces

Interface	Label on the HW	Number of interfaces	Connector type	Additional info
Power Connector	DC IN	1	Low power circular	APPA, APPB, APPC
Antenna connector	ANT	4	4.3-10	-
Remote Electrical Tilt	RET	1	8-pin circular	RS-485
External Alarm Connection	EAC	1	MDR26	4 alarm inputs and 1 control output
Optical interface	OPT	2	SFP+	9.8 Gbps, CPRI; Nokia IP seal

Table 165 AHMA interfaces (Cont.)

Interface	Label on the HW	Number of interfaces	Connector type	Additional info
Grounding		1	M8 or dual M5 screws	-
Fan	FAN	1	Nokia fan	Located on the opposite side



WARNING! Risk of electric shock

Before turning RF power on, RF ports have to be terminated by nominal 50 Ω load (for example, feeder with antenna). However, if these conditions are not met, the plastic caps that are delivered within the unused RF ports should remain in place. The plastic caps isolate RF port from the environment, and thus provide electric shock security in case RF power is accidentally on.

Antenna Line Devices (ALDs) support

Table 166 AHMA ALD support

ALD support	Value
AISG	ANT1, ANT3: AISG 2.0/3.0 ANT2, ANT4: AISG 3.0 ping receiver RET: AISG 2.0/3.0
Voltage	ANT1, ANT3, RET: 14.5 V
Power per port	30 W, 45 W total

Functional block diagram

Figure 45 AHMA functional block diagram

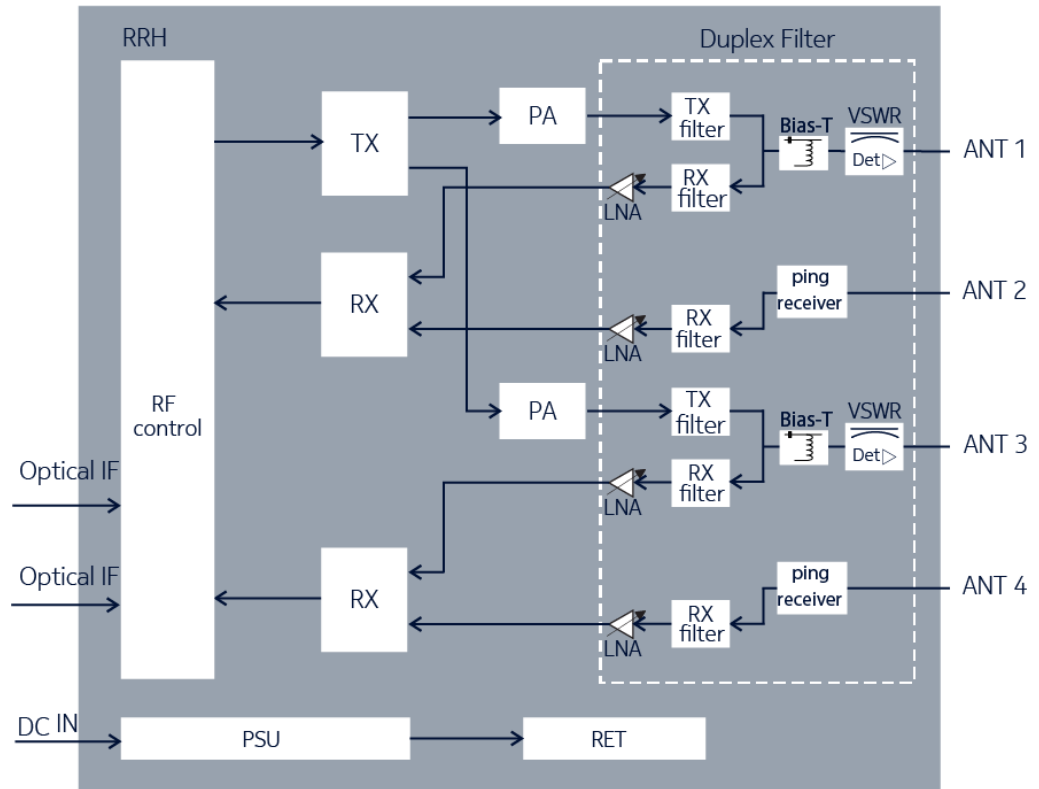

Electrical specifications

Table 167 AHMA electrical specifications

Property	Value
Nominal supply voltage	-48.0 V DC
Nominal input voltage range	-40.5 V DC to -57.0 V DC
Extended input voltage range	-36.0 V DC to -40.5 V DC -57.0 V DC to -60.0 V DC



Note: The minimum start-up voltage is -40.5 V DC. If the input voltage is below/beyond the extended limits, the unit might shut down.

Power consumption

Typical power consumption [W] for 48VDC input, at 25°C, representative of typical product performance under the same conditions (HW variant, SW version, configuration, environment, and so on) with +/- 10% margin. Average = (6h low hour load, 10h medium hour load and 8h busy hour load) / 24h

Configurations explained on examples:

- GSM/WCDMA: 2/2/2 = three sectors, two carriers/TRXs per sector
- LTE:
 - o 2/2/2 2Tx = three sectors, two carriers per sector, 2Tx per carrier

o 1+1/1+1/1+1 4Tx = three dual-band sectors, one carrier per sector per band, 4Tx per carrier

Some radio units are capable of providing only one sector coverage. Then the power values in the table consider deployment of three radio units.

Table 168 AHMA power consumption in LTE mode

Configuration	Output power per carrier [W]	Power consumption ETSI 202706 average P_{RRH} , static	Power consumption ETSI 202706 busy hour load $P_{BH\ RRH}$, static	Power consumption 100% RF power load $P_{100\% \ RRH}$
1/1/1 2Tx	2x60	659	804	1145
1/1/1 2Tx	2x40	530	626	850
1/1/1 2Tx	2x30	493	568	731
1/1/1 2Tx	2x20	436	488	595

Power reduction



Note: The maximum power reduction (`dlCellPwrRed`) value is 20 dB. High power reduction values may cause radio outages.

Related optional items

- ASFA AirScale 2 fan unit 300 (473968A)
- APAA AirScale AC-DC Power Unit 760W (473936A)
- AMAA AirScale 2 casing for RRH aux-units (474141A):
 - APAC AirScale AC PDU 1 to 3 (474142A)
 - APAA AirScale AC-DC Power Unit 760W (473936A) - maximum three units per one AMAA
- AMGD AirScale 2 cover 300 x 126-150 (474270A)
- AMBF AirScale book mount kit 126-150 (474278A)
- FPKA Flexi Pole Mounting Kit (30-120 mm) (471649A)
- FPKC Flexi Pole Mounting Kit (60-300 mm) (472821A)
- AMPA Pole Mounting Kit (30-120 mm) (473879A)
- AMFA AirScale 2 FPKx fixing adapter (474289A)
- AMFC AirScale 2 19" rack fixing 300 (474291A)
- AMFN AirScale 2 casing adapter RRH 300 (474664A)
- AMRA AirScale one clip bracket 51-125 (474580A)
- AMRC AirScale one clip rail 600 mm (474583A)
- ASAA AirScale 2 MDR26-open EAC cable 5 m (474288A)
- APPA AirScale 2 26A DC plug 3.3-10 mm² (474281A)
- APPB AirScale 2 55A DC plug 3.3-10 mm² (474282A)
- APPC AirScale 2 55A DC plug 10-16 mm² (474283A)
- ACPA AirScale 2 Fiber Protection (474297A)

Installation options

- Wall installation: vertical, horizontal with optional fan
- Pole installation: vertical, horizontal with optional fan
- Vertical RAS mounting
- Book mounting
- One-clip rail mounting



NOTICE: Install this RRH in a vertical orientation with connectors on the bottom side, to ensure convection cooling. For horizontal installation fans are required.

Dimensions and weight

Table 169 AHMA dimensions and weight

Property	Value	Dimensions orientation
Height	Core RRH: 336 mm (13.25 in.) With mounting brackets: 428 mm (16.87 in.)	
Width	309 mm (12.17 in.)	
Depth	Core RRH: 130 mm (5.12 in.) With mounting brackets: 153 mm (6.02 in.)	
Weight	14 kg (30.9 lbs)	

Environmental specifications

Table 170 AHMA environmental specifications

Property	Value
Maximum operational outdoor temperature (in the shade)	55°C (131°F)
Maximum operational outdoor temperature (in the sun)	55°C (131°F)
Maximum indoor temperature	45°C (113°F)
Minimum operational temperature	-40°C (-40°F)
IP rating	IP65

LTE4118 feature interdependencies

The *LTE4118:AirScale RRH 2T4R B20 120W AHMA* feature is impacted by the following features:

- *LTE112: Cell Bandwidth - 20 MHz* enables LTE 20 MHz carriers.
- *LTE113: Cell Bandwidth - 15 MHz* enables LTE 15 MHz carriers
- *LTE114: Cell Bandwidth - 10 MHz* enables LTE 10 MHz carriers.
- *LTE115: Cell Bandwidth - 5 MHz* enables LTE 5 MHz carriers.
- With *LTE614: Distributed Site*, AHMA can be used in distributed sites with up to 23km fiber length to the system module.
- *LTE1103: Load based Power Saving for multilayer networks*

- *LTE1203: Load based Power Saving mode with TX power reduction or path switching off*
- *LTE2508: BTS Embedded Power Meter for Energy Efficiency Monitoring*
- *With LTE2541: Nokia CPRI RRH/RFM chaining , AHMA supports Nokia CPRI chain of up to 4 radio units.*
- *LTE3036: Micro DTX extension*

5.2.14 Nokia AirScale RRH 2T4R B28 120 W (AHPC)

AHPC is introduced by LTE4615: Nokia AirScale RRH 2T4R B28 120 W (AHPC).

Functional description

Table 171 AHPC functional specification

Property	Value
Output power	2x60 W
QAM	256 QAM (DL) 64 QAM (UL)
Number of TXRX	2T4R
Outdoor installation	Yes
Supported technologies (standalone and MSR)	FDD-LTE, 5G-ready
IoT support	NB-IoT in band, guard band (GB), standalone (SA)
TX frequency range	758 – 803 MHz
RX frequency range	703 – 748 MHz
DL filter bandwidth	45 MHz
UL filter bandwidth	45 MHz
iBW (instantaneous bandwidth)	45 MHz
oBW (occupied bandwidth)	45 MHz
Number of carriers per pipe	Up to 6
Supported bandwidths	3, 5, 10, 15, 20 MHz
PIM cancellation	Yes

Interfaces

Figure 46 AHPC interfaces

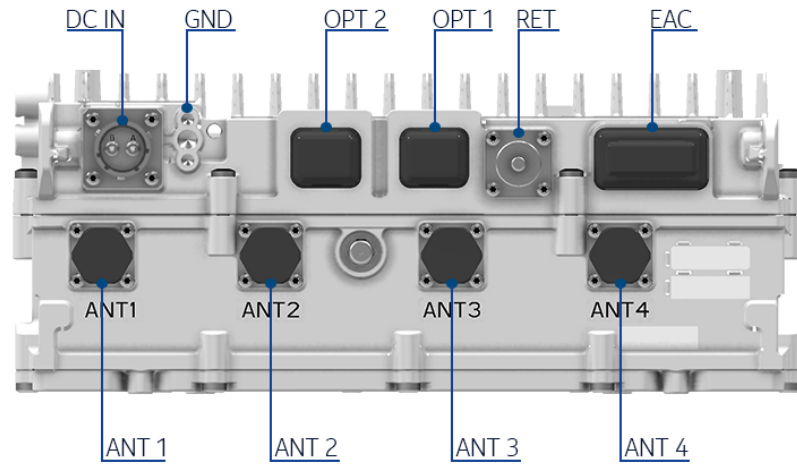

Table 172 AHPC interfaces

Interface	Label on the HW	Number of interfaces	Connector type	Additional info
Power Connector	DC IN	1	Low power circular	APPA, APPB, APPC
Antenna connector	ANT	4	4.3-10	-
Remote Electrical Tilt	RET	1	8-pin circular	RS-485
Optical interface	SFP	2	SFP+	9.8 Gbps, CPRI; Nokia IP seal
External Alarm Connection	EAC	1	MDR26	4 alarm inputs and 1 control output
Grounding	GND	1	M8 or dual M5 screws	-



WARNING! Risk of electric shock

Before turning RF power on, RF ports have to be terminated by nominal 50 Ω load (for example, feeder with antenna). However, if these conditions are not met, the plastic caps that are delivered within the unused RF ports should remain in place. The plastic caps isolate RF port from the environment, and thus provide electric shock security in case RF power is accidentally on.

Antenna Line Devices (ALDs) support

Table 173 AHPC ALD support

ALD support through RS485/8-pin circular ports	Value
AISG	RET: AISG 2.0/3.0
Voltage	RET: 14.5 V
Power per port	30 W

Functional block diagram

Figure 47 AHPC functional block diagram

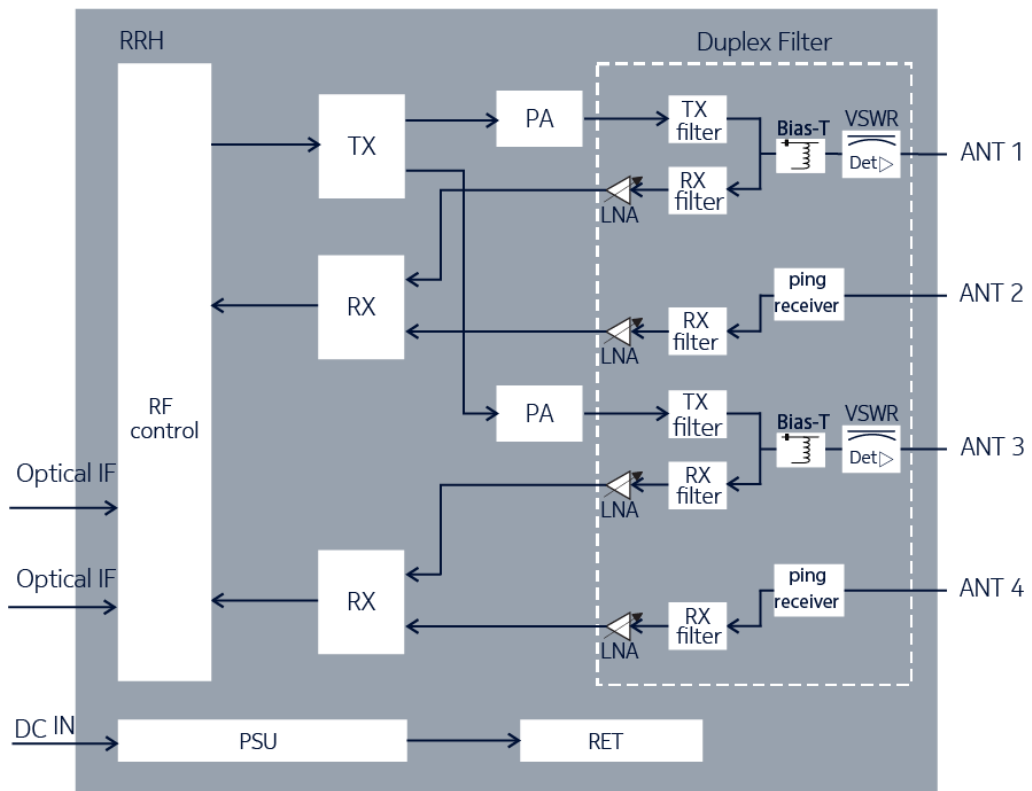

Electrical specifications

Table 174 AHPC electrical specifications

Property	Value
Nominal supply voltage	-48.0 V DC
Nominal input voltage range	-40.5 V DC to -57.0 V DC
Extended input voltage range	-36.0 V DC to -40.5 V DC -57.0 V DC to -60.0 V DC



Note: The minimum start-up voltage is -40.5 V DC. If the input voltage is below/beyond the extended limits, the unit might shut down.

Power consumption

Typical power consumption [W] for 48VDC input, at 25°C, representative of typical product performance under the same conditions (HW variant, SW version, configuration, environment, and so on) with +/- 10% margin. Average = (6h low hour load, 10h medium hour load and 8h busy hour load) / 24h

Configurations explained on examples:

- GSM/WCDMA: 2/2/2 = three sectors, two carriers/TRXs per sector
- LTE:
 - o 2/2/2 2Tx = three sectors, two carriers per sector, 2Tx per carrier
 - o 1+1/1+1/1+1 4Tx = three dual-band sectors, one carrier per sector per band, 4Tx per carrier

Some radio units are capable of providing only one sector coverage. Then the power values in the table consider deployment of three radio units.

Table 175 AHPC power consumption in LTE mode

Configuration	Output power per carrier [W]	Power consumption ETSI 202706 average P_{RRH} , static	Power consumption ETSI 202706 busy hour load $P_{BH\ RRH}$, static	Power consumption 100% RF power load $P_{100\% \ RRH}$
1/1/1 2Tx	2x60	713	857	1168
1/1/1 2Tx	2x40	602	704	891
1/1/1 2Tx	2x30	533	614	757
1/1/1 2Tx	2x20	464	521	620

Power reduction



Note: The maximum power reduction (`dlCellPwrRed`) value is 20 dB. High power reduction values may cause radio outages.

Related optional items

- APAA AirScale AC-DC Power Unit 760W (473936A)
- AMAA AirScale 2 casing for RRH aux-units (474141A):
 - APAC AirScale AC PDU 1 to 3 (474142A)
 - APAA AirScale AC-DC Power Unit 760W (473936A) - maximum three units per one AMAA
- AMGC AirScale 2 cover 300 x 101-125 (474269A)
- AMBF AirScale book mount kit 126-150 (474278A)
- FPKA Flexi Pole Mounting Kit (30-120 mm) (471649A)
- FPKC Flexi Pole Mounting Kit (60-300 mm) (472821A)
- AMPA Pole Mounting Kit (30-120 mm) (473879A)
- AMFA AirScale 2 FPKx fixing adapter (474289A)
- AMFN AirScale 2 casing adapter RRH 300 (474664A)
- AMRA AirScale one clip bracket 51-125 (474580A)
- AMRC AirScale one clip rail 600 mm (474583A)
- ASAA AirScale 2 MDR26-open EAC cable 5 m (474288A)

- APPA AirScale 2 26A DC plug 3.3-10 mm² (474281A)

Installation options

- Pole mounting, vertical only
- Wall mounting, vertical only
- Compatible to RAS mounting, vertical
- Bookshelf mounting

Dimensions and weight

Table 176 AHPC dimensions and weight

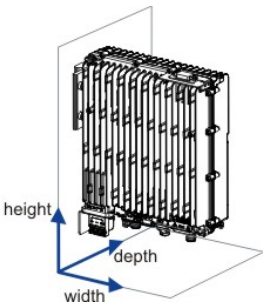
Property	Value	Dimensions orientation
Height	Core RRH: 336 mm (13.25 in.) With mounting brackets: 428 mm (16.87 in.)	
Width	309 mm (12.17 in.)	
Depth	Core RRH: 125 mm (4.92 in.) With mounting brackets: 149 mm (5.86 in.)	
Weight	13.6 kg (30.0 lb)	
Volume	Without ID Cover: 12.2 l	

Environmental specifications

Table 177 AHPC environmental specifications

Property	Value
Maximum operational outdoor temperature (stand-alone outdoor pole or mast)	55°C (131°F)
Maximum operational indoor and outdoor temperature (wall and shelter)	45°C (113°F)
Minimum operational temperature	-40°C (-40°F)
IP rating	IP65

LTE4615 feature interdependencies

The *LTE4615: Nokia AirScale RRH 2T4R B28 120W (AHPC)* feature is impacted by the following features:

- *LTE112: Cell Bandwidth - 20 MHz*
Needs to be enabled to use LTE 20 MHz carriers.
- *LTE113: Cell Bandwidth - 15 MHz*
Needs to be enabled to use LTE 15 MHz carriers.
- *LTE114: Cell Bandwidth - 10 MHz*
Needs to be enabled to use LTE 10 MHz carriers.
- *LTE115: Cell Bandwidth - 5 MHz*

- Needs to be enabled to use LTE 5 MHz carriers.
- *LTE116: Cell Bandwidth - 3 MHz*
Needs to be enabled to use LTE 3 MHz carriers.
- *With LTE614: Distributed Site*
AHPD can be used in distributed sites with up to 23 km fiber length to the system module.
- *LTE1103: Load based Power Saving for multi-layer networks*
Needs to be enabled to use Load based Power Saving for multi-layer networks.
- *LTE1203: Load based Power Saving with Tx path switching off*
Needs to be enabled to use Load based Power Saving with Tx path switching off.
- *LTE2508: BTS Embedded Power Meter for Energy Efficiency Monitoring*
Needs to be enabled to use BTS Embedded Power Meter for Energy Efficiency Monitoring.
- *LTE2541: Nokia CPRI RRH/RFM chaining*
Provides support for chaining.
- *LTE3036: Micro DTX extension*
Needs to be enabled to use Micro DTX extension.

5.2.15 Nokia AirScale RRH 2T4R B28/n28 120 W (AHPD)

AHPD is introduced by LTE4660, SR002080, 5GC001081: Nokia AirScale RRH 2T4R B28/n28 120 W (AHPD).

Functional description

Table 178 AHPD functional specification

Property	Value
Output power	2x60 W
QAM	256 QAM (DL) 64 QAM (UL)
Number of TXRX	2T4R
Outdoor installation	Yes
Supported technologies (standalone and MSR)	FDD-LTE, 5G
IoT support	NB-IoT in band, guard band (GB), standalone (SA)
TX frequency range	758 - 788 MHz
RX frequency range	703 - 733 MHz
DL filter bandwidth	30 MHz
UL filter bandwidth	30 MHz
iBW (instantaneous bandwidth)	30 MHz
oBW (occupied bandwidth)	30 MHz
Number of carriers per pipe	Up to 3 carriers in total for all supported RATs
Supported bandwidths	LTE: 3, 5, 10, 15, 20 MHz

Table 178 AHPD functional specification (Cont.)

Property	Value
	5G: 5, 10, 15, 20 MHz
PIM cancellation	Yes

Interfaces

Figure 48 AHPD interfaces

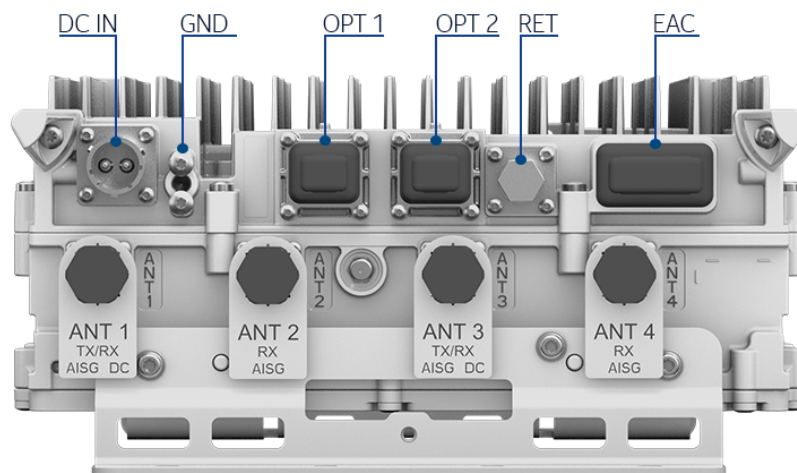

Table 179 AHPD interfaces

Interface	Label on the HW	Number of interfaces	Connector type	Additional info
Power Connector	DC IN	1	Low power circular	APPA, APPB, APPC
Antenna connector	ANT	4	4.3-10	-
Remote Electrical Tilt	RET	1	8-pin circular	RS-485
External Alarm Connection	EAC	1	MDR26	4 alarm inputs and 1 control output
Optical interface	OPT	2	SFP+	9.8 Gbps, CPRI; Nokia IP seal
Grounding		1	M8 or dual M5 screws	-
Fan	FAN	1	Nokia fan	Located on the opposite side



WARNING! Risk of electric shock

Before turning RF power on, RF ports have to be terminated by nominal 50 Ω load (for example, feeder with antenna). However, if these conditions are not met, the plastic caps that are delivered within the unused RF ports should remain in place. The plastic caps isolate RF port from the environment, and thus provide electric shock security in case RF power is accidentally on.

Antenna Line Devices (ALDs) support

Table 180 AHPD ALD support

ALD support	Value
AISG	AISG 2.0 and 3.0: ANT 1, ANT 2, ANT 3, ANT 4 and RET Power supply: ANT1 and ANT3
CWA (for non-AISG installations)	No
Voltage	14.5 V
Power per port	30 W

Functional block diagram

Figure 49 AHPD functional block diagram

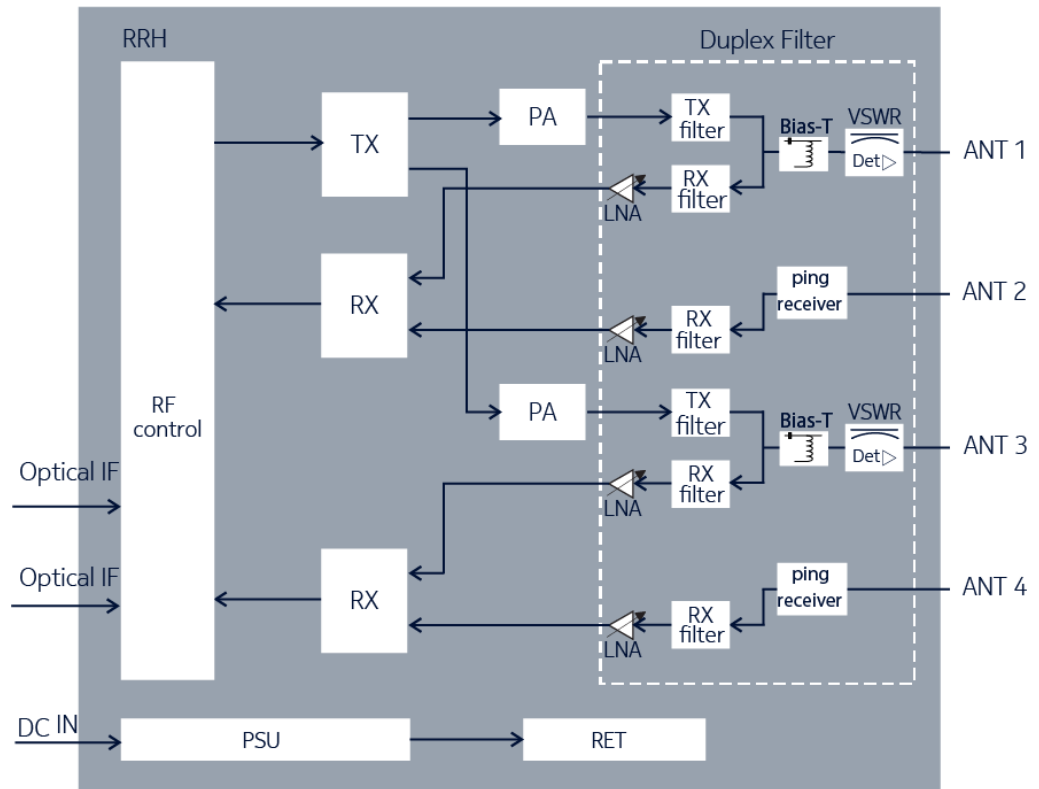

Electrical specifications

Table 181 AHPD electrical specifications

Property	Value
Nominal supply voltage	-48.0 V DC
Nominal input voltage range	-40.5 V DC to -57.0 V DC
Extended input voltage range	-36.0 V DC to -40.5 V DC -57.0 V DC to -60.0 V DC



Note: The minimum start-up voltage is -40.5 V DC. If the input voltage is below/beyond the extended limits, the unit might shut down.

Power consumption

Typical power consumption [W] for 48VDC input, at 25°C, representative of typical product performance under the same conditions (HW variant, SW version, configuration, environment, and so on) with +/- 10% margin. Average = (6h low hour load, 10h medium hour load and 8h busy hour load) / 24h

Configurations explained on examples:

- GSM/WCDMA: 2/2/2 = three sectors, two carriers/TRXs per sector
- LTE:
 - o 2/2/2 2Tx = three sectors, two carriers per sector, 2Tx per carrier
 - o 1+1/1+1/1+1 4Tx = three dual-band sectors, one carrier per sector per band, 4Tx per carrier

Some radio units are capable of providing only one sector coverage. Then the power values in the table consider deployment of three radio units.

Table 182 AHPD power consumption in LTE mode

Configuration	Output Power per carrier (W)	Power consumption (W), ETSI 202706 average load P _{RRH} , static	Power consumption (W), ETSI 202706 busy hour load P _{BH} RRH, static	Power consumption (W), 100% RF power load P _{100% RRH}
1/1/1 2Tx	2x60	693	846	1180
1/1/1 2Tx	2x40	578	683	884
1/1/1 2Tx	2x30	507	589	741
1/1/1 2Tx	2x20	456	518	620

Power reduction



Note: The maximum power reduction (dlCellPwrRed) value is 20 dB. High power reduction values may cause radio outages.

Related optional items

- ASFA AirScale 2 fan unit 300 (473968A)
- APAA AirScale AC-DC Power Unit 760W (473936A)
- AMAA AirScale 2 casing for RRH aux-units (474141A):

- APAC AirScale AC PDU 1 to 3 (474142A)
- APAA AirScale AC-DC Power Unit 760W (473936A) - maximum three units per one AMAA
- AMGD AirScale 2 cover 300 x 126-150 (474270A)
- AMBF AirScale book mount kit 126-150 (474278A)
- FPKA Flexi Pole Mounting Kit (30-120 mm) (471649A)
- FPKC Flexi Pole Mounting Kit (60-300 mm) (472821A)
- AMPA Pole Mounting Kit (30-120 mm) (473879A)
- AMFA AirScale 2 FPKx fixing adapter (474289A)
- AMFC AirScale 2 19" rack fixing 300 (474291A)
- AMFN AirScale 2 casing adapter RRH 300 (474664A)
- AMRA AirScale one clip bracket 51-125 (474580A)
- AMRC AirScale one clip rail 600 mm (474583A)
- ASAA AirScale 2 MDR26-open EAC cable 5 m (474288A)
- APPA AirScale 2 26A DC plug 3.3-10 mm² (474281A)
- APPB AirScale 2 55A DC plug 3.3-10 mm² (474282A)
- APPC AirScale 2 55A DC plug 10-16 mm² (474283A)
- ACPA AirScale 2 Fiber Protection (474297A)

Installation options

- Wall installation: vertical, horizontal with optional fan
- Pole installation: vertical, horizontal with optional fan
- Vertical RAS mounting
- Book mounting
- One-clip rail mounting



NOTICE: Install this RRH in a vertical orientation with connectors on the bottom side, to ensure convection cooling. For horizontal installation fans are required.

Dimensions and weight

Table 183 AHPD dimensions and weight

Property	Value	Dimensions orientation
Height	Core RRH: 336 mm (13.25 in.) With mounting brackets: 428 mm (16.87 in.)	
Width	309 mm (12.17 in.)	
Depth	Core RRH: 130 mm (5.12 in.) With mounting brackets: 153 mm (6.02 in.)	
Weight	14 kg (30.9 lb)	

Environmental specifications

Table 184 AHPD environmental specifications

Property	Value
Maximum operational outdoor temperature (in the shade)	55°C (131°F)
Maximum operational outdoor temperature (in the sun)	55°C (131°F)
Maximum indoor temperature	45°C (113°F)
Minimum operational temperature	-40°C (-40°F)
IP rating	IP65

LTE4660 feature interdependencies

The *LTE4660: Nokia AirScale RRH 2T4R B28 120 W (AHPD)* feature is impacted by the following features:

- *LTE112: Cell Bandwidth - 20 MHz*
Needs to be enabled to use LTE 20 MHz carriers.
- *LTE113: Cell Bandwidth - 15 MHz*
Needs to be enabled to use LTE 15 MHz carriers.
- *LTE114: Cell Bandwidth - 10 MHz*
Needs to be enabled to use LTE 10 MHz carriers.
- *LTE115: Cell Bandwidth - 5 MHz*
Needs to be enabled to use LTE 5 MHz carriers.
- *LTE116: Cell Bandwidth - 3 MHz*
Needs to be enabled to use LTE 3 MHz carriers.
- With *LTE614: Distributed Site*,
AHPD can be used in distributed sites with up to 23km fiber length to the system module.
- *LTE1103: Load based Power Saving for multilayer networks* or *LTE1203: Load based Power Saving mode with TX power reduction or path switching off*
Needs to be enabled to use PA shutdown feature.
- *LTE2508: BTS Embedded Power Meter for Energy Efficiency Monitoring*
Needs to be enabled to use BTS Embedded Power Meter for Energy Efficiency Monitoring.
- With *LTE2541: Nokia CPRI RRH/RFM chaining* ,
AHPD supports Nokia CPRI chain of up to 4 radio units.
- *LTE3036: Micro DTX extension* allows further power saving.

5.2.16 Nokia AirScale RRH 2T4R B28 120 W (AHPE)

AHPE is introduced by LTE5359: AirScale RRH 2T4R B28 120 W AHPE.

Functional description

Table 185 AHPE functional specification

Property	Value
Output power	2x60 W
QAM	256 QAM (DL)

Table 185 AHPE functional specification (Cont.)

Property	Value
	64 QAM (UL)
Number of TXRX	2T4R
Outdoor installation	Yes
Supported technologies (standalone and MSR)	FDD-LTE, 5G-ready
IoT support	NB-IoT in band, guard band (GB), standalone (SA)
TX frequency range	773–803 MHz
RX frequency range	718–748 MHz
DL filter bandwidth	30 MHz
UL filter bandwidth	30 MHz
iBW (instantaneous bandwidth)	30 MHz
oBW (occupied bandwidth)	30 MHz
Number of carriers per pipe	Up to 4
Supported bandwidths	3, 5, 10, 15, 20 MHz
PIM cancellation	Yes

Interfaces

Figure 50 AHPE interfaces

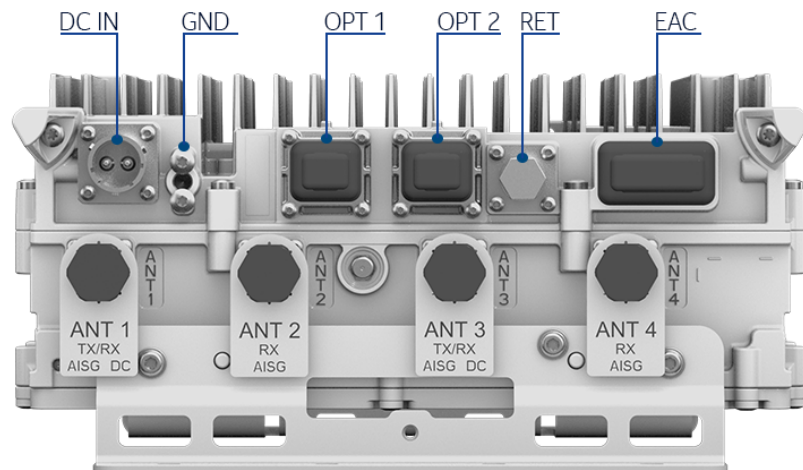



Table 186 AHPE interfaces

Interface	Label on the HW	Number of interfaces	Connector type	Additional info
Power Connector	DC IN	1	Low power circular	APPA, APPB, APPC
Antenna connector	ANT	4	4.3-10	-
Remote Electrical Tilt	RET	1	8-pin circular	RS-485
External Alarm Connection	EAC	1	MDR26	4 alarm inputs and 1 control output
Optical interface	OPT	2	SFP+	9.8 Gbps, CPRI; Nokia IP seal
Grounding		1	M8 or dual M5 screws	-
Fan	FAN	1	Nokia fan	Located on the opposite side



WARNING! Risk of electric shock

Before turning RF power on, RF ports have to be terminated by nominal 50 Ω load (for example, feeder with antenna). However, if these conditions are not met, the plastic caps that are delivered within the unused RF ports should remain in place. The plastic caps isolate RF port from the environment, and thus provide electric shock security in case RF power is accidentally on.

Antenna Line Devices (ALDs) support

Table 187 AHPE ALD support

ALD support	Value
AISG	ANT1, ANT3: AISG 2.0/3.0 ANT2, ANT4: AISG 3.0 ping receiver RET: AISG 2.0/3.0
Voltage	ANT1, ANT3, RET: 14.5 V
Power per port	30 W, 45 W total

Functional block diagram

Figure 51 AHPE functional block diagram

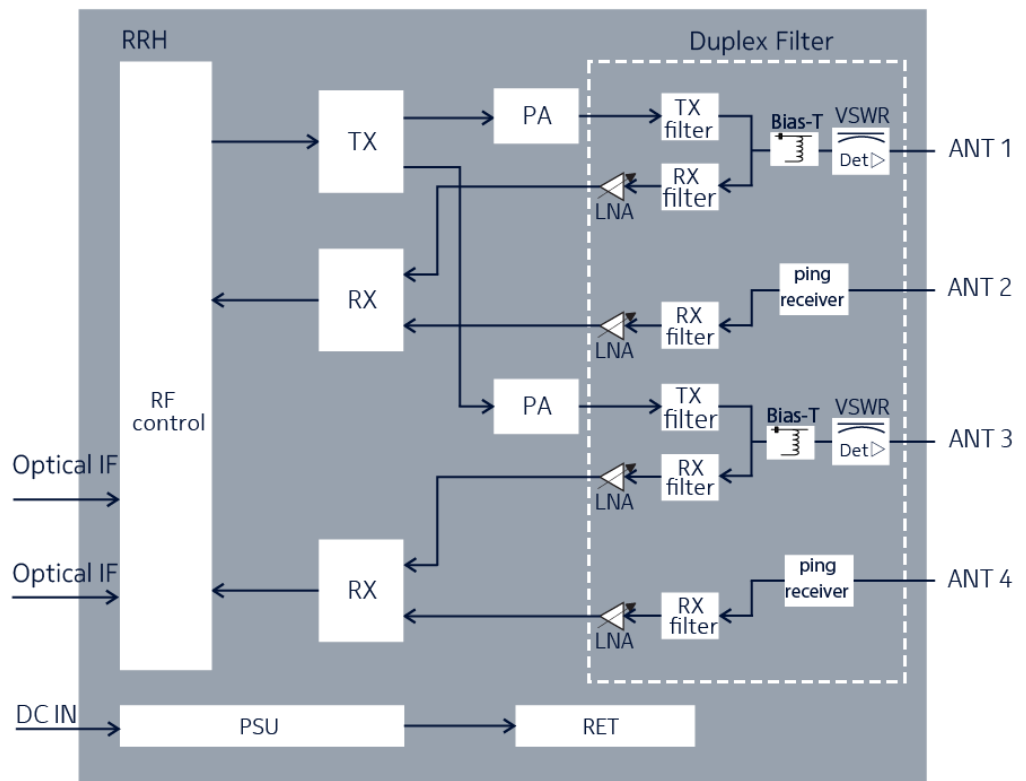

Electrical specifications

Table 188 AHPE electrical specifications

Property	Value
Nominal supply voltage	-48.0 V DC
Nominal input voltage range	-40.5 V DC to -57.0 V DC
Extended input voltage range	-36.0 V DC to -40.5 V DC -57.0 V DC to -60.0 V DC



Note: The minimum start-up voltage is -40.5 V DC. If the input voltage is below/beyond the extended limits, the unit might shut down.

Power consumption

Typical power consumption [W] for 48VDC input, at 25°C, representative of typical product performance under the same conditions (HW variant, SW version, configuration, environment, and so on) with +/- 10% margin. Average = (6h low hour load, 10h medium hour load and 8h busy hour load) / 24h

Configurations explained on examples:

- GSM/WCDMA: 2/2/2 = three sectors, two carriers/TRXs per sector
- LTE:

- o 2/2/2 2Tx = three sectors, two carriers per sector, 2Tx per carrier
- o 1+1/1+1/1+1 4Tx = three dual-band sectors, one carrier per sector per band, 4Tx per carrier

Some radio units are capable of providing only one sector coverage. Then the power values in the table consider deployment of three radio units.

Table 189 AHPE power consumption in LTE mode

Configuration	Output Power per carrier (W)	Power consumption (W), ETSI 202706 average load $P_{RRH, static}$	Power consumption (W), ETSI 202706 busy hour load $P_{BH, RRH, static}$	Power consumption (W), 100% RF power load $P_{100\% RRH}$
1/1/1 2Tx	2x60	688	847	1237
1/1/1 2Tx	2x40	542	646	887
1/1/1 2Tx	2x20	423	482	598

Power reduction

Table 190 AHPE power reduction in 256 QAM

Single carrier [dB]	Multi-carrier [dB]
0.6	1.2



Note: The maximum power reduction (`dlCellPwrRed`) value is 20 dB. High power reduction values may cause radio outages.

Related optional items

- ASFA AirScale 2 fan unit 300 (473968A)
- APAA AirScale AC-DC Power Unit 760W (473936A)
- AMAA AirScale 2 casing for RRH aux-units (474141A):
 - APAC AirScale AC PDU 1 to 3 (474142A)
 - APAA AirScale AC-DC Power Unit 760W (473936A) - maximum three units per one AMAA
- AMGD AirScale 2 cover 300 x 126-150 (474270A)
- AMBF AirScale book mount kit 126-150 (474278A)
- FPKA Flexi Pole Mounting Kit (30-120 mm) (471649A)
- FPKC Flexi Pole Mounting Kit (60-300 mm) (472821A)
- AMPA Pole Mounting Kit (30-120 mm) (473879A)
- AMFA AirScale 2 FPKx fixing adapter (474289A)
- AMFC AirScale 2 19" rack fixing 300 (474291A)
- AMFN AirScale 2 casing adapter RRH 300 (474664A)
- AMRA AirScale one clip bracket 51-125 (474580A)
- AMRC AirScale one clip rail 600 mm (474583A)
- ASAA AirScale 2 MDR26-open EAC cable 5 m (474288A)
- APPA AirScale 2 26A DC plug 3.3-10 mm² (474281A)
- APPB AirScale 2 55A DC plug 3.3-10 mm² (474282A)

- APPC AirScale 2 55A DC plug 10-16 mm² (474283A)
- ACPA AirScale 2 Fiber Protection (474297A)

Installation options

- Pole: vertical, horizontal with an optional fan
- Wall: vertical, horizontal with an optional fan
- Vertical RAS mounting
- Book mounting
- One-clip rail mounting



NOTICE: Install this RRH in a vertical orientation with connectors on the bottom side, to ensure convection cooling. For horizontal installation fans are required.

Dimensions and weight

Table 191 AHPE dimensions and weight

Property	Value	Dimensions orientation
Height	Core RRH: 336 mm (13.25 in.) With mounting brackets: 428 mm (16.87 in.)	
Width	309 mm (12.17 in.)	
Depth	Core RRH: 130 mm (5.12 in.) With mounting brackets: 153 mm (6.02 in.)	
Weight	14.0 kg (30.9 lb)	

Environmental specifications

Table 192 AHPE environmental specifications

Property	Value
Maximum operational outdoor temperature (in the shade)	55°C (131°F)
Maximum operational outdoor temperature (in the sun)	55°C (131°F)
Maximum indoor temperature	45°C (113°F)
Minimum operational temperature	-40°C (-40°F)
IP rating	IP65

LTE5359 feature interdependencies

The *LTE5359: AirScale RRH 2T4R B28 120 W AHPE* feature is impacted by the following features:

- *LTE112: Cell Bandwidth - 20 MHz* enables LTE 20 MHz carriers.
- *LTE113: Cell Bandwidth - 15 MHz* enables LTE 15 MHz carriers

- *LTE114: Cell Bandwidth - 10 MHz* enables LTE 10 MHz carriers.
- *LTE115: Cell Bandwidth - 5 MHz* enables LTE 5 MHz carriers.
- *LTE116: Cell Bandwidth - 3 MHz* enables LTE 3 MHz carriers.
- With *LTE614: Distributed Site*, AHPE can be used in distributed sites with up to 23 km (14.29 mi) fiber length to the system module.
- With *LTE2541: Nokia CPRI RRH/RFM chaining*, AHPE supports Nokia CPRI chain of up to four radio units.
- Power saving features:
 - *LTE1103: Load based Power Saving for multilayer networks*
 - *LTE1203: Load based Power Saving mode with TX power reduction or path switching off*
 - *LTE2508: BTS Embedded Power Meter for Energy Efficiency Monitoring*
 - *LTE3036: Micro DTX extension*

5.2.17 Nokia AirScale RRH 4T4R B1/n1 320 W (AHGD)

AHGD is introduced by SR002924/5GC002565 : MSR support for AirScale RRH 4T4R B1/n1 320 W (AHGD).

Functional description

Table 193 AHGD functional specification

Property	Value
Output power	4x80 W
QAM	256 QAM (DL) 64 QAM (UL)
Number of TXRX	4T4R
Outdoor installation	Yes
Supported technologies (standalone and MSR)	LTE, WCDMA, WCDMA-LTE 5G NR
TX frequency range	2110 – 2165 MHz
RX frequency range	1920 – 1975 MHz
DL filter bandwidth	55 MHz
UL filter bandwidth	55 MHz
iBW (instantaneous bandwidth)	55 MHz
oBW (occupied bandwidth)	55 MHz
Number of carriers per pipe	Up to 4
Supported bandwidths	5 MHz, 10 MHz, 15 MHz, 20 MHz
PIM cancellation	No

Interfaces

Figure 52 AHGD interfaces

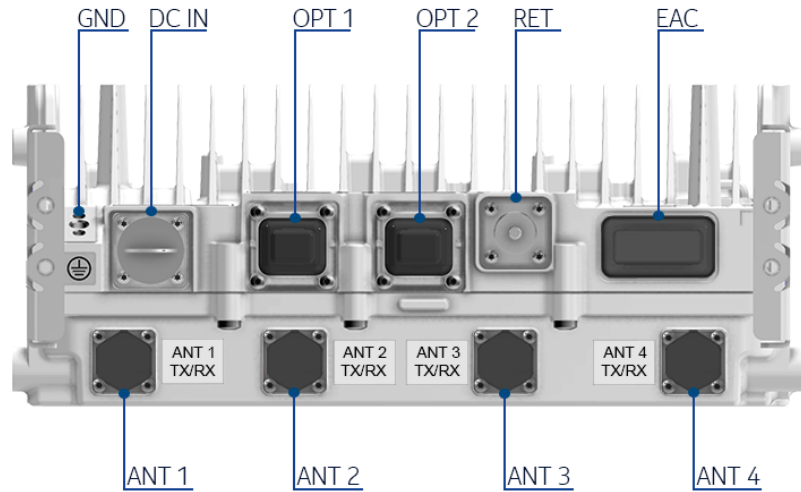



Table 194 AHGD interfaces

Interface	Label on the HW	Number of interfaces	Connector type	Additional info
Power Connector	DC IN	1	High power circular	APPB, APPC
Antenna connector	ANT	4	4.3-10	AISG on all ports, BiasT support on ANT1 & ANT3 Has features that prevent damage if mating with a 4.1-9.5 connector is attempted
Remote Electrical Tilt	RET	1	8-pin circular	RS-485
External Alarm Connection	EAC	1	MDR26	4 alarm inputs and 1 control output
Optical interface	OPT	2	SFP+	9.8 Gbps, CPRI; Nokia IP seal
Grounding		1	1xM8 or 2xM5 screw	-
Fan	FAN	1	Nokia fan	Located on the heat sink side



WARNING! Risk of electric shock

Before turning RF power on, RF ports have to be terminated by nominal 50 Ω load (for example, feeder with antenna). However, if these conditions are not met, the plastic caps that are delivered within the unused RF ports should remain in place. The plastic caps isolate RF port from the environment, and thus provide electric shock security in case RF power is accidentally on.

Antenna Line Devices (ALDs) support

Table 195 AHGD ALD support

ALD support	Value
AISG	2.0, 3.0
CWA (for non-AISG installations)	No
Voltage	RET: 14.5 V
RET port power	30 W

Functional block diagram

Figure 53 AHGD functional block diagram

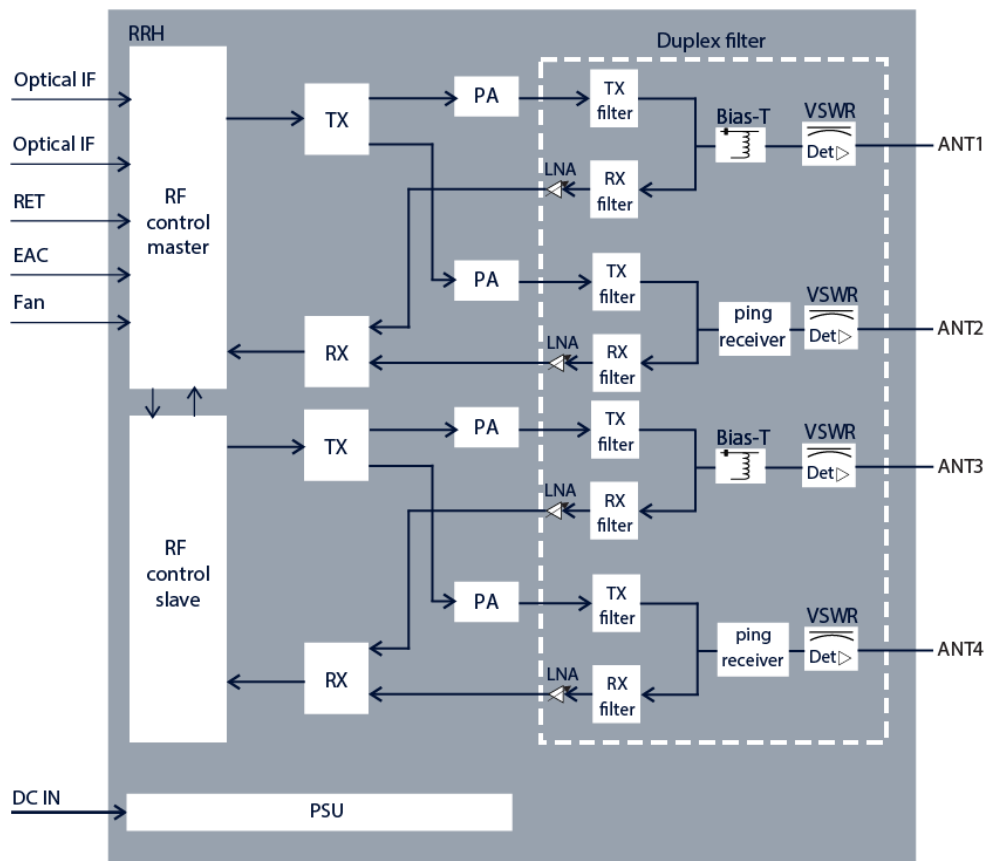

Electrical specifications

Table 196 AHGD electrical specifications

Property	Value
Nominal supply voltage	–48.0 V DC
Nominal input voltage range	–40.5 V DC to –57.0 V DC
Extended input voltage range	–36.0 V DC to –40.5 V DC –57.0 V DC to –60.0 V DC



Note: The minimum start-up voltage is –40.5 V DC. If the input voltage is below/beyond the extended limits, the unit might shut down.

Power consumption



Note: AHGD power consumption will be provided in future releases.

Related optional items

- ASFC AirScale 2 fan unit 600 (474484A)
- AMBF AirScale book mount kit 126-150 (474278A)
- FPKA Flexi Pole Mounting Kit (30-120 mm) (471649A)
- FPKC Flexi Pole Mounting Kit (60-300 mm) (472821A)
- AMPA Pole Mounting Kit (30-120 mm) (473879A)
- AMFD AirScale 2 FPKx Fixing Adapter 600 (474293A)
- ASAA AirScale 2 MDR26-open EAC cable 5 m (474288A)
- APPB AirScale 2 55A DC plug 3.3-10 mm² (474282A)
- APPC AirScale 2 55A DC plug 10-16 mm² (474283A)
- ACPA AirScale 2 Fiber Protection (474297A)
- AMRB AirScale one clip bracket 126-200 (474581A)
- AMRC AirScale one clip rail 600 mm (474583A)

Installation options

- Wall installation
- Pole installation
- Vertical book mount
- Horizontal book mount (fan is required)
- One-clip rail installation

Power reduction

Table 197 Recommended AHGD power reduction per band, in 256 QAM

Single carrier [dB]	Dual carrier [dB]	Triple carrier [dB]	Quad carrier [dB]
0	0.7	0.7	0.9



Note: The maximum power reduction (`dlCellPwrRed`) value is 20 dB. High power reduction values may cause radio outages.

Dimensions and weight

Table 198 AHGD dimensions and weight

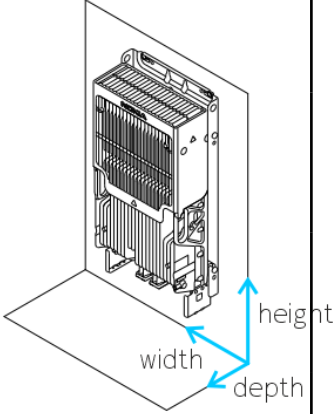
Property	Value	Dimensions orientation
Height	Core RRH: 560 mm (22.04 in.) With upper and lower mounting brackets: 675 mm (26.57 in.)	
Width	Core RRH: 308 mm (12.12 in.) With mounting brackets: 327 mm (12.87 in.)	
Depth	Core RRH: 149 mm (5.86 in.) With mounting brackets: 160 mm (6.29 in.)	
Weight	30 kg (66.1 lb)	

Environmental specifications

Table 199 AHGD environmental specifications

Property	Value
Maximum operational outdoor temperature (in the shade) with fan or 10.8 km/h (6.7 mph) wind	55°C (131°F)
Maximum operational outdoor temperature (in the sun) with fan or 10.8 km/h (6.7 mph) wind	50°C (122°F)
Maximum indoor temperature	45°C (113°F)
Minimum operational temperature	-40°C (-40°F)
IP rating	IP65



NOTICE: To ensure proper cooling for an RRH mounted in a vertical position, it should always be mounted with the connectors on the bottom side. For horizontal mounting, fans are required.

SR002924 feature interdependencies

The *SR002924: MSR support for AirScale RRH 4T4R B1 320 W (AHGD)* feature is impacted by the following features:

- *LTE 112: Cell Bandwidth - 20 MHz* enables 20 MHz carriers.
- *LTE 113: Cell Bandwidth - 15 MHz* enables 15 MHz carriers.
- *LTE 114: Cell Bandwidth - 10 MHz* enables 10 MHz carriers.
- *LTE 115: Cell Bandwidth - 5 MHz* enables 5 MHz carriers.
- With *LTE 614: Distributed Site*, AHGD can be used in distributed sites with up to 23 km fiber length to the system module.
- *LTE2428: Nokia CPRI in FDD-LTE* provides support for CPRI interface.
- *LTE2863: PIM Cancellation for AirScale 2.0 Radios* enables PIM cancellation feature (licensed feature).

- Power saving features:
 - LTE1103: Load based Power Saving for multi-layer networks
 - LTE1203: Load based Power Saving with Tx path switching off
 - LTE2508: BTS Embedded Power Meter for Energy Efficiency Monitoring
 - LTE3036: Micro DTX extension

5.2.18 Nokia AirScale RRH 4T4R B3/n3 160 W (AHEB)

AHEB is introduced by LTE2784, SR001206, 5GC001099: Nokia AirScale RRH 4T4R B3/n3 160 W (AHEB).

Functional description

Table 200 AHEB functional specification

Property	Value
Output power	4x40 W
Number of TXRX	4T4R
Outdoor installation	Yes
Supported technologies (standalone and MSR)	GSM, FDD-LTE, 5G B3: GSM, GSM-LTE RF sharing
TX frequency range	1805-1880 MHz
RX frequency range	1710-1785 MHz
DL filter bandwidth	75 MHz
UL filter bandwidth	75 MHz
iBW (instantaneous bandwidth)	75 MHz
oBW (occupied bandwidth)	75 MHz
Number of carriers per pipe	Up to 8 carriers in total for all supported RATs (including max 2 GSM TRXs)
Supported bandwidths	LTE: 1.4, 3, 5, 10, 15, 20 MHz 5G: 5, 10, 15, 20 MHz
PIM cancellation	Yes

Interfaces

Figure 54 AHEB interfaces

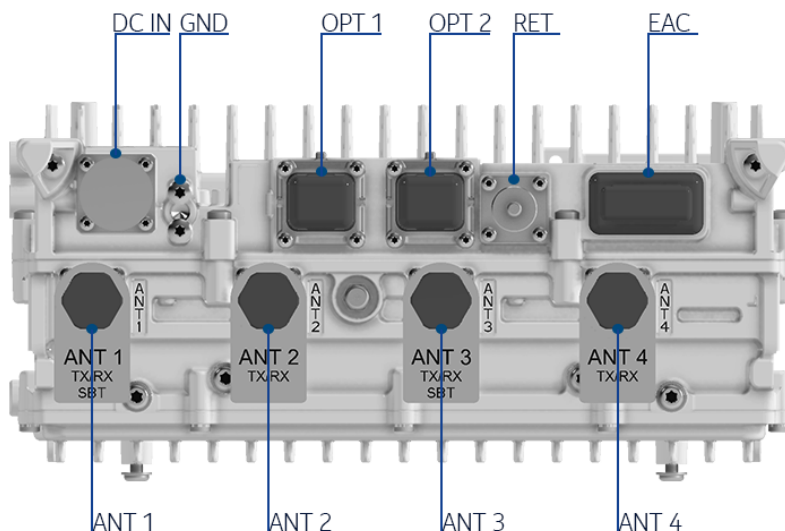

Table 201 AHEB interfaces

Interface	Label on the HW	Number of interfaces	Connector type	Additional info
Power Connector	DC IN	1	Low power circular	APPA, APPB, APPC
Antenna connector	ANT	4	4.3-10	-
Remote Electrical Tilt	RET	1	8-pin circular	RS-485
External Alarm Connection	EAC	1	MDR26	4 alarm inputs and 1 control output
Optical interface	OPT	2	SFP+	9.8 Gbps, CPRI; Nokia IP seal
Ground		1	M8 or dual M5 screws	-
Fan	Fan	1	Nokia fan	Located on the opposite side



WARNING! Risk of electric shock

Before turning RF power on, RF ports have to be terminated by nominal 50 Ω load (for example, feeder with antenna). However, if these conditions are not met, the plastic caps that are delivered within the unused RF ports should remain in place. The plastic caps isolate RF port from the environment, and thus provide electric shock security in case RF power is accidentally on.

Antenna Line Devices (ALDs) support

Table 202 AHEB ALD support

ALD support	Value
AISG	ANT1, ANT3, RET: AISG 2.0/3.0 ANT2, ANT4: AISG 3.0 Ping receiver
CWA (for non-AISG installations)	No
Voltage	ANT1, ANT3: 14.5 V RET: 14.5 V
Power per port	ANT1, ANT3: 30 W RET: 45 W
Power	45 W

Functional block diagram

Figure 55 AHEB functional block diagram

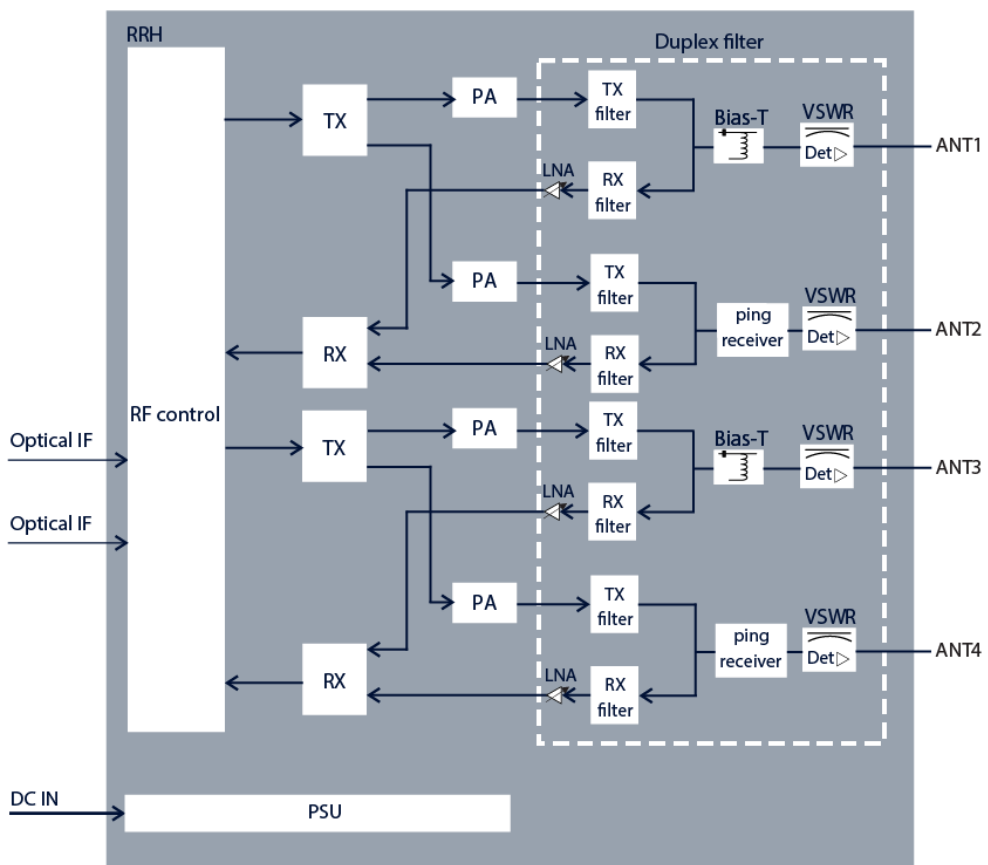

Electrical specifications

Table 203 AHEB electrical specifications

Property	Value
Nominal supply voltage	-48.0 V DC

Table 203 AHEB electrical specifications (Cont.)

Property	Value
Nominal input voltage range	-40.5 V DC to -57.0 V DC
Extended input voltage range	-36.0 V DC to -40.5 V DC -57.0 V DC to -60.0 V DC



Note: The minimum start-up voltage is -40.5 V DC. If the input voltage is below/beyond the extended limits, the unit might shut down.

Power consumption

Typical power consumption [W] for 48VDC input, at 25°C, representative of typical product performance under the same conditions (HW variant, SW version, configuration, environment, and so on) with +/- 10% margin. Average = (6h low hour load, 10h medium hour load and 8h busy hour load) / 24h

Configurations explained on examples:

- GSM/WCDMA: 2/2/2 = three sectors, two carriers/TRXs per sector
- LTE:
 - o 2/2/2 2Tx = three sectors, two carriers per sector, 2Tx per carrier
 - o 1+1/1+1/1+1 4Tx = three dual-band sectors, one carrier per sector per band, 4Tx per carrier

Some radio units are capable of providing only one sector coverage. Then the power values in the table consider deployment of three radio units.

Table 204 AHEB power consumption in LTE mode

Configuration	Output power per carrier [W]	Power consumption ETSI 202706 average P _{RRH, static}	Power consumption ETSI 202706 busy hour load P _{BH RRH, static}	Power consumption 100% RF power load P _{100% RRH}
1/1/1 4Tx	4x40	866	1063	1516
1/1/1 4Tx	4x30	791	947	1280
1/1/1 4Tx	4x20	644	745	953
1/1/1 2Tx	2x40	530	629	853
1/1/1 2Tx	2x30	492	569	735
1/1/1 2Tx	2x20	419	470	575

Power reduction

Table 205 AHEB power reduction in 256 QAM

Single carrier [dB]	Dual carrier [dB]
0	0.8



Note: The maximum power reduction (`dlCellPwrRed`) value is 20 dB. High reduction values may cause radio outages.

Related optional items

- ASFA AirScale 2 fan unit 300 (473968A)
- APAA AirScale AC-DC Power Unit 760W (473936A)
- AMAA AirScale 2 casing for RRH aux-units (474141A):
 - APAC AirScale AC PDU 1 to 3 (474142A)
 - APAA AirScale AC-DC Power Unit 760W (473936A) - maximum three units per one AMAA
- AMGD AirScale 2 cover 300 x 126-150 (474270A)
- AMBF AirScale book mount kit 126-150 (474278A)
- FPKA Flexi Pole Mounting Kit (30-120 mm) (471649A)
- FPKC Flexi Pole Mounting Kit (60-300 mm) (472821A)
- AMPA Pole Mounting Kit (30-120 mm) (473879A)
- AMFA AirScale 2 FPKx fixing adapter (474289A)
- AMFC AirScale 2 19" rack fixing 300 (474291A)
- AMFN AirScale 2 casing adapter RRH 300 (474664A)
- AMRA AirScale one clip bracket 51-125 (474580A)
- AMRC AirScale one clip rail 600 mm (474583A)
- ASAA AirScale 2 MDR26-open EAC cable 5 m (474288A)
- APPA AirScale 2 26A DC plug 3.3-10 mm² (474281A)
- APPB AirScale 2 55A DC plug 3.3-10 mm² (474282A)
- APPC AirScale 2 55A DC plug 10-16 mm² (474283A)
- ACPA AirScale 2 Fiber Protection (474297A)

Installation options

- Wall installation
- Pole installation
- Flat mount without fans on wall or pole
- Vertical book mount without fans
- Horizontal book mount with fans
- Inside the Radio Antenna System (RAS) without fans
- One-clip rail mounting



NOTICE: Install this RRH in a vertical orientation with connectors on the bottom side, to ensure convection cooling. For horizontal installation fans are required.

Dimensions and weight

Table 206 AHEB dimensions and weight

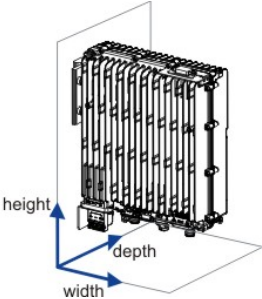
Property	Value	Dimensions orientation
Height	Core RRH: 336 mm (13.2 in.) With upper and lower mounting brackets: 427 mm (16.8 in.)	
Depth	Core RRH: 140 mm (5.5 in.) With mounting brackets: 164.5 mm (6.5 in.) With cover and mounting brackets: 183.5 mm (7.2 in.)	
Width	Core RRH: 295 mm (11.6 in.) With cover and mounting brackets: 322 mm (12.7 in.)	
Weight	15.5 kg (34.2 lb)	
Volume	Without cover (core only): 13.9 l	

Environmental specifications

Table 207 AHEB environmental specifications

Property	Value
Maximum operational outdoor temperature in the shade, assuming wind speed is 3 m/s (at constant high ambient temperature, maximum output power might be limited)	55°C (131°F)
Maximum operational outdoor temperature in the sun, assuming wind speed is 3 m/s (at constant high ambient temperature, maximum output power might be limited)	50°C (122°F)
Maximum indoor temperature, assuming wind speed is 0 m/s, valid for fanless products (at constant high ambient temperature, maximum output power might be limited)	40°C (104°F)
Minimum operational temperature (including cold start)	-40°C (-40°F)
IP rating	IP65

LTE2784 feature interdependencies

The *LTE2784:AirScale RRH 4T4R B3 160W AHEB* feature is impacted by the following features:

- *LTE112: Cell Bandwidth - 20 MHz* needs to be enabled to use LTE 20 MHz carriers.
- *LTE113: Cell Bandwidth - 15 MHz* needs to be enabled to use LTE 15 MHz carriers.

- *LTE114: Cell Bandwidth - 10 MHz*
needs to be enabled to use LTE 10 MHz carriers.
- *LTE115: Cell Bandwidth - 5 MHz*
needs to be enabled to use LTE 5 MHz carriers.
- *LTE116: Cell Bandwidth - 3 MHz*
needs to be enabled to use LTE 3 MHz carriers.
- *LTE117: Cell Bandwidth - 1.4 MHz*
needs to be enabled to use LTE 1.4 MHz carriers.
- *With LTE614: Distributed Site,*
AHEB can be used in distributed sites with up to 23 km fiber length to the system module.
- *LTE1103: Load based Power Saving for multi-layer networks*
needs to be enabled to use Load based Power Saving for multi-layer networks.
- *LTE1203: Load based Power Saving with Tx path switching off*
needs to be enabled to use Load based Power Saving with Tx path switching off.
- *LTE2508: BTS Embedded Power Meter for Energy Efficiency Monitoring*
needs to be enabled to use BTS Embedded Power Meter for Energy Efficiency Monitoring.
- *LTE2541: Nokia CPRI RRH/RFM chaining*
AHEB supports Nokia CPRI chain of up to four radio units.
- *With LTE2829: Supported RAS Installation options in FL17 Release,*
RAS installation options are defined.
- *LTE3036: Micro DTX extension* allows further power saving.

5.2.19 Nokia AirScale RRH 4T4R B3 160 W (AHEH)

AHEH is introduced by LTE4686/SR002165: Nokia AirScale RRH 4T4R B3 160 W (AHEH).

Functional description

Table 208 AHEH functional specification

Property	Value
Output power	4x40 W
QAM	256 QAM (DL) 64 QAM (UL)
Number of TXRX	4T4R
Outdoor installation	Yes
Supported technologies (standalone and MSR)	GSM, FDD-LTE, 5G-ready LTE-GSM RF Sharing
IoT support	NB-IoT in band, guard band (GB), standalone (SA)
TX frequency range	1805 - 1860 MHz
RX frequency range	1710 - 1765 MHz

Table 208 AHEH functional specification (Cont.)

Property	Value
DL filter bandwidth	55 MHz
UL filter bandwidth	55 MHz
iBW (instantaneous bandwidth)	55 MHz
oBW (occupied bandwidth)	55 MHz
Number of carriers per pipe	Up to 8
Supported bandwidths	5, 10, 15, 20 MHz
PIM Cancellation	Yes

Interfaces

Figure 56 AHEH interfaces

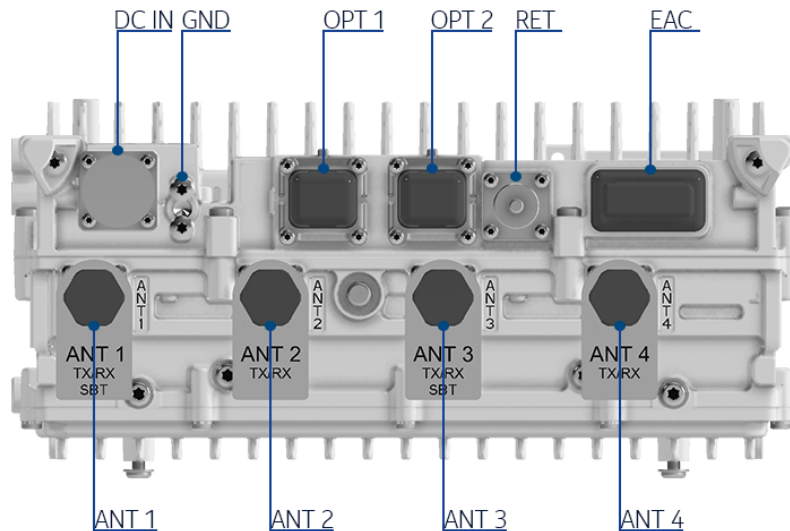



Table 209 AHEH interfaces

Interface	Label on the HW	Number of interfaces	Connector type	Additional info
Power Connector	DC IN	1	Low power circular	APPA, APPB, APPC
Antenna connector	ANT	4	4.3-10	-
Remote Electrical Tilt	RET	1	8-pin circular	RS-485
External Alarm Connection	EAC	1	MDR26	4 alarm inputs and 1 control output

Table 209 AHEH interfaces (Cont.)

Interface	Label on the HW	Number of interfaces	Connector type	Additional info
Optical interface	OPT	2	SFP+	9.8 Gbps, CPRI; Nokia IP seal
Ground		1	M8 or dual M5 screws	-
Fan	Fan	1	Nokia fan	Located on the opposite side

**WARNING! Risk of electric shock**

Before turning RF power on, RF ports have to be terminated by nominal 50 Ω load (for example, feeder with antenna). However, if these conditions are not met, the plastic caps that are delivered within the unused RF ports should remain in place. The plastic caps isolate RF port from the environment, and thus provide electric shock security in case RF power is accidentally on.

Antenna Line Devices (ALDs) support

Table 210 AHEH ALD support

ALD support	Value
AISG	ANT1, ANT3, RET: AISG 2.0/3.0 ANT2, ANT4: AISG 3.0 Ping receiver
CWA (for non-AISG installations)	No
Voltage	ANT1, ANT3: 14.5 V RET: 14.5 V
Power per port	ANT1, ANT3: 30 W RET: 45 W
Power	45 W

Functional block diagram

Figure 57 AHEH functional block diagram

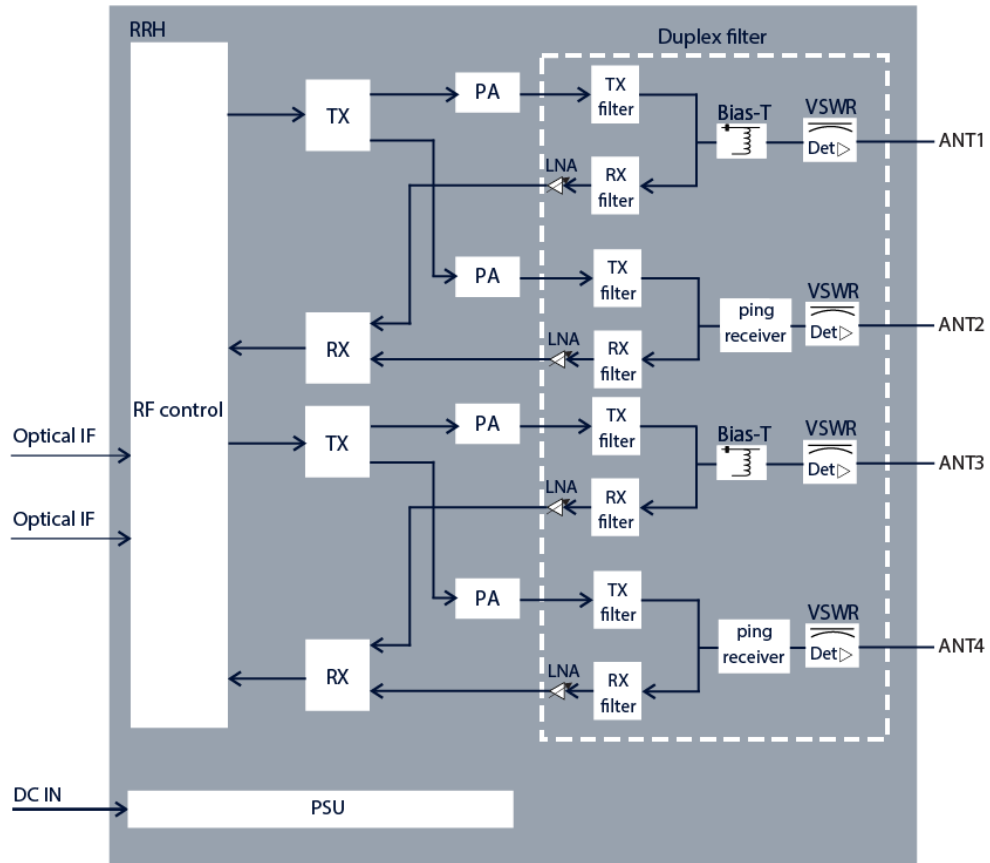

Electrical specifications

Table 211 AHEH electrical specifications

Property	Value
Nominal supply voltage	-48.0 V DC
Nominal input voltage range	-40.5 V DC to -57.0 V DC
Extended input voltage range	-36.0 V DC to -40.5 V DC -57.0 V DC to -60.0 V DC



Note: The minimum start-up voltage is -40.5 V DC. If the input voltage is below/beyond the extended limits, the unit might shut down.

Power consumption

Typical power consumption [W] for 48VDC input, at 25°C, representative of typical product performance under the same conditions (HW variant, SW version, configuration, environment, and so on) with +/- 10% margin. Average = (6h low hour load, 10h medium hour load and 8h busy hour load) / 24h

Configurations explained on examples:

- GSM/WCDMA: 2/2/2 = three sectors, two carriers/TRXs per sector

- LTE:
 - o 2/2/2 2Tx = three sectors, two carriers per sector, 2Tx per carrier
 - o 1+1/1+1/1+1 4Tx = three dual-band sectors, one carrier per sector per band, 4Tx per carrier

Some radio units are capable of providing only one sector coverage. Then the power values in the table consider deployment of three radio units.

Table 212 AHEH power consumption in LTE mode

Configuration	Output Power per carrier (W)	Power consumption (W), ETSI 202706 average load $P_{RRH, static}$	Power consumption (W), ETSI 202706 busy hour load $P_{BH, RRH, static}$	Power consumption (W), 100% RF power load $P_{100\% RRH}$
1/1/1 4Tx	4x40	879	1076	1557
1/1/1 4Tx	4x20	657	755	965
1/1/1 2Tx	2x40	540	637	874
1/1/1 2Tx	2x20	430	479	581

Power reduction

Table 213 AHEH power reduction in 256 QAM

Single carrier [dB]	Dual carrier [dB]
0	0.8



Note: The maximum power reduction (`d1CellPwrRed`) value is 20 dB. High power reduction values may cause radio outages.

Related optional items

- ASFA AirScale 2 fan unit 300 (473968A)
- APAA AirScale AC-DC Power Unit 760W (473936A)
- AMAA AirScale 2 casing for RRH aux-units (474141A):
 - APAC AirScale AC PDU 1 to 3 (474142A)
 - APAA AirScale AC-DC Power Unit 760W (473936A) - maximum three units per one AMAA
- AMGD AirScale 2 cover 300 x 126-150 (474270A)
- AMBF AirScale book mount kit 126-150 (474278A)
- FPKA Flexi Pole Mounting Kit (30-120 mm) (471649A)
- FPKC Flexi Pole Mounting Kit (60-300 mm) (472821A)
- AMPA Pole Mounting Kit (30-120 mm) (473879A)
- AMFA AirScale 2 FPKx fixing adapter (474289A)
- AMFC AirScale 2 19" rack fixing 300 (474291A)
- AMFN AirScale 2 casing adapter RRH 300 (474664A)
- AMRA AirScale one clip bracket 51-125 (474580A)
- AMRC AirScale one clip rail 600 mm (474583A)
- ASAA AirScale 2 MDR26-open EAC cable 5 m (474288A)

- APPA AirScale 2 26A DC plug 3.3-10 mm² (474281A)
- ACPA AirScale 2 Fiber Protection (474297A)

Installation options

- Pole mounting: vertical, horizontal with optional fan
- Wall mounting: vertical, horizontal with optional fan
- Compatible with RAS mounting
- Book mounting
- One-clip rail mounting



NOTICE: Install this RRH in a vertical orientation with connectors on the bottom side, to ensure convection cooling. For horizontal installation fans are required.

Dimensions and weight

Table 214 AEH dimensions and weight

Property	Value	Dimensions orientation
Height	Core RRH: 336 mm (13.2 in.) With upper and lower mounting brackets: 427.5 mm (16.8 in.)	
Depth	Core RRH: 140 mm (5.5 in.) With mounting brackets: 164.5 mm (6.5 in.) With cover and mounting brackets: 183.5 mm (7.2 in.)	
Width	Core RRH: 295 mm (11.6 in.) With cover: 322 mm (12.7 in.)	
Weight	15.5 kg (34.2 lb)	
Volume	Without cover (core only): 13.9 l	

Environmental specifications

Table 215 AEH environmental specifications

Property	Value
Maximum operational outdoor temperature (in the shade)	55°C (131°F)
Maximum operational outdoor temperature (in the sun)	55°C (131°F)
Maximum indoor temperature	45°C (113°F)
Minimum operational temperature	-40°C (-40°F)
IP rating	IP65

LTE4686 feature interdependencies

The *LTE4686:AirScale RRH 4T4R B3 160W AHEH* feature is impacted by the following features:

- *LTE112: Cell Bandwidth - 20 MHz* enables LTE 20 MHz carriers.
- *LTE113: Cell Bandwidth - 15 MHz* enables LTE 15 MHz carriers.
- *LTE114: Cell Bandwidth - 10 MHz* enables LTE 10 MHz carriers.
- *LTE115: Cell Bandwidth - 5 MHz* enables LTE 5 MHz carriers.
- With *LTE614: Distributed Site*, AHEH can be used in distributed sites with up to 23 km fiber length to the system module.
- *LTE1103: Load Based Power Saving For Multi-layer Networks* enables PA shutdown feature.
- *LTE1203: Load Based Power Saving With Tx Path Sswitching Off* enables PA shutdown feature.
- *LTE2508: BTS Embedded Power Meter for Energy Efficiency Monitoring* enables to use energy metering feature.
- With *LTE2541: Nokia CPRI RRH/RFM chaining*, AHEH supports Nokia CPRI chain of up to 4 radio units.
- *LTE3036: Micro DTX Extension* enables Micro DTX feature.

5.2.20 Nokia AirScale RRH 4T4R B7/n7 160 W (AHHB)

AHHB is introduced by LTE3137/5GC001839: Nokia AirScale RRH 4T4R B7/n7 160 W (AHHB).

Functional description

Table 216 AHHB functional specification

Property	Value
Output power	4x40 W
QAM	256 QAM (DL) 64 QAM (UL)
Number of TXRX	4T4R
Outdoor installation	Yes
Supported technologies (standalone and MSR)	FDD-LTE, 5G NR
IoT support	NB-IoT in band, guard band (GB), standalone (SA)
TX frequency range	2620 - 2690 MHz
RX frequency range	2500 - 2570 MHz
DL filter bandwidth	70 MHz
UL filter bandwidth	70 MHz
iBW (instantaneous bandwidth)	70 MHz
oBW (occupied bandwidth)	70 MHz
Number of carriers per pipe	Up to 8

Table 216 AHHB functional specification (Cont.)

Property	Value
Supported bandwidths	5, 10, 15, 20 MHz
PIM cancellation	Yes

Interfaces

Figure 58 AHHB interfaces

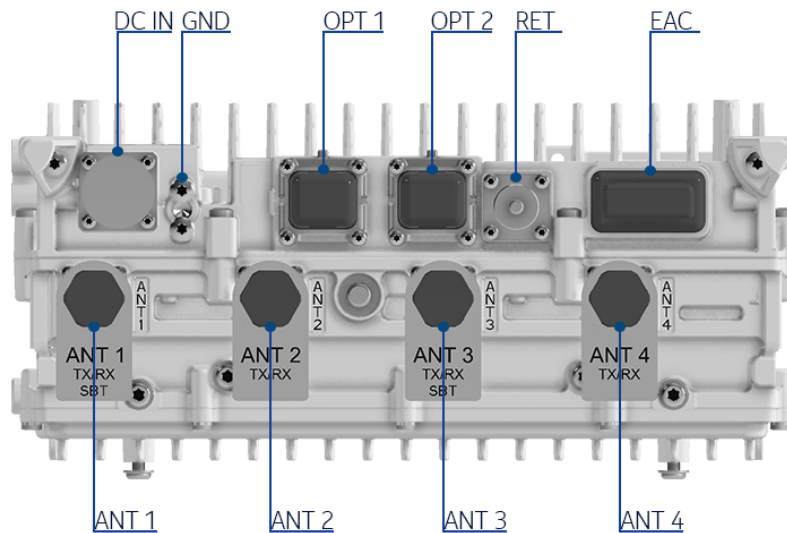

Table 217 AHHB interfaces

Interface	Label on the HW	Number of interfaces	Connector type	Additional info
Power Connector	DC IN	1	Low power circular	APPA, APPB, APPC
Antenna connector	ANT	4	4.3-10	-
Remote Electrical Tilt	RET	1	8-pin circular	RS-485
External Alarm Connection	EAC	1	MDR26	4 alarm inputs and 1 control output
Optical interface	OPT	2	SFP+	9.8 Gbps, CPRI; Nokia IP seal
Grounding	GND	1	M8 or dual M5 screws	-
Fan	FAN	1	Nokia fan	Located on the opposite side



WARNING! Risk of electric shock

Before turning RF power on, RF ports have to be terminated by nominal 50 Ω load (for example, feeder with antenna). However, if these conditions are not met, the plastic caps that are delivered within the unused RF ports should remain in place. The plastic caps isolate RF port from the environment, and thus provide electric shock security in case RF power is accidentally on.

Antenna Line Devices (ALDs) support

Table 218 AHHB ALD support

ALD support	Value
AISG	ANT1, ANT3, RET: AISG 2.0/3.0 ANT2, ANT4: AISG 3.0 Ping receiver
CWA (for non-AISG installations)	No
Voltage	ANT1, ANT3: 14.5 V RET: 14.5 V
Power per port	ANT1, ANT3: 30 W RET: 45 W
Power	45 W

Functional block diagram

Figure 59 AHHB functional block diagram

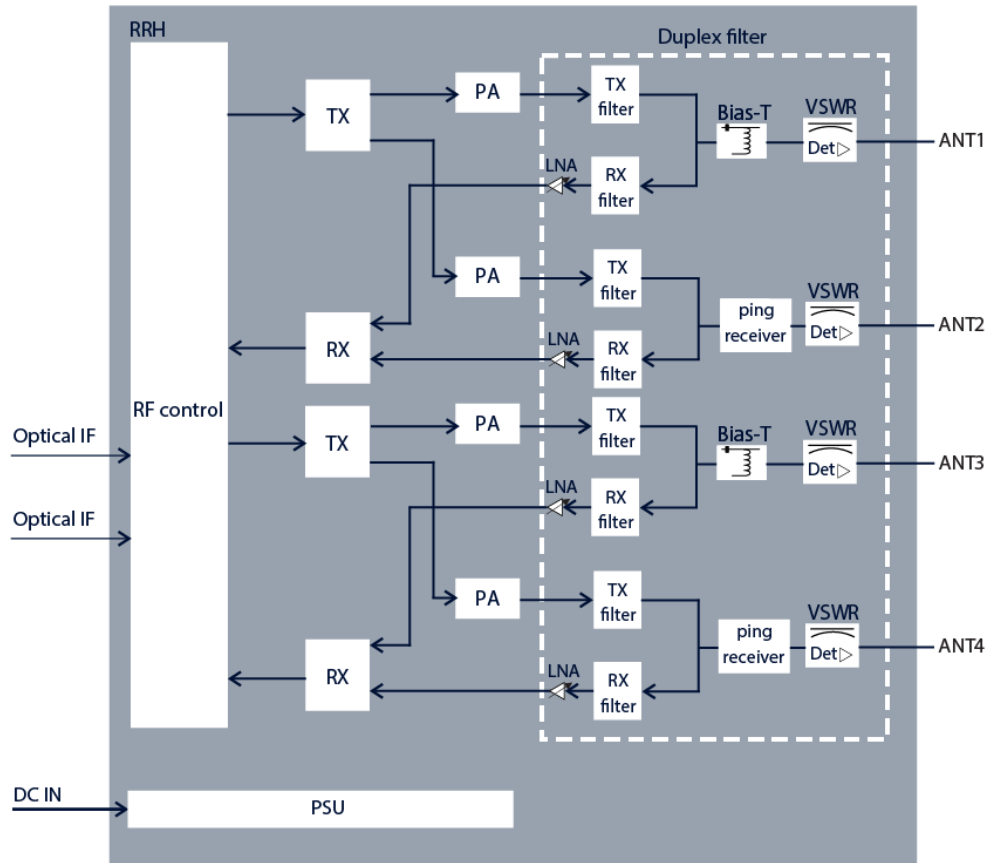

Electrical specifications

Table 219 AHHB electrical specifications

Property	Value
Nominal supply voltage	-48.0 V DC
Nominal input voltage range	-40.5 V DC to -57.0 V DC
Extended input voltage range	-36.0 V DC to -40.5 V DC -57.0 V DC to -60.0 V DC



Note: The minimum start-up voltage is -40.5 V DC. If the input voltage is below/beyond the extended limits, the unit might shut down.

Power consumption

Typical power consumption [W] for 48VDC input, at 25°C, representative of typical product performance under the same conditions (HW variant, SW version, configuration, environment, and so on) with +/- 10% margin. Average = (6h low hour load, 10h medium hour load and 8h busy hour load) / 24h

Configurations explained on examples:

- GSM/WCDMA: 2/2/2 = three sectors, two carriers/TRXs per sector

- LTE:
 - o 2/2/2 2Tx = three sectors, two carriers per sector, 2Tx per carrier
 - o 1+1/1+1/1+1 4Tx = three dual-band sectors, one carrier per sector per band, 4Tx per carrier

Some radio units are capable of providing only one sector coverage. Then the power values in the table consider deployment of three radio units.

Table 220 AHHB power consumption in LTE mode

Configuration	Output power per carrier [W]	Power consumption ETSI 202706 average P_{RRH} , static	Power consumption ETSI 202706 busy hour load $P_{BH\ RRH}$, static	Power consumption 100% RF power load $P_{100\% \ RRH}$
1/1/1 4Tx	4x40	950	1241	1833
1/1/1 4Tx	4x30	837	1063	1539
1/1/1 4Tx	4x20	632	777	1053
1/1/1 2Tx	2x40	571	711	999
1/1/1 2Tx	2x30	516	624	843
1/1/1 2Tx	2x20	414	483	621

Power reduction

Table 221 Recommended AHHB power reduction in 256 QAM

Single carrier [dB]	Dual carrier [dB]
0	0.8



Note: The maximum power reduction (`dlCellPwrRed`) value is 20 dB. High reduction values may cause radio outages.

Related optional items

- ASFA AirScale 2 fan unit 300 (473968A)
- APAA AirScale AC-DC Power Unit 760W (473936A)
- AMAA AirScale 2 casing for RRH aux-units (474141A):
 - APAC AirScale AC PDU 1 to 3 (474142A)
 - APAA AirScale AC-DC Power Unit 760W (473936A) - maximum three units per one AMAA
- AMGD AirScale 2 cover 300 x 126-150 (474270A)
- AMBF AirScale book mount kit 126-150 (474278A)
- FPKA Flexi Pole Mounting Kit (30-120 mm) (471649A)
- FPKC Flexi Pole Mounting Kit (60-300 mm) (472821A)
- AMPA Pole Mounting Kit (30-120 mm) (473879A)
- AMFA AirScale 2 FPKx fixing adapter (474289A)
- AMFC AirScale 2 19" rack fixing 300 (474291A)
- AMFN AirScale 2 casing adapter RRH 300 (474664A)

- AMRA AirScale one clip bracket 51-125 (474580A)
- AMRC AirScale one clip rail 600 mm (474583A)
- ASAA AirScale 2 MDR26-open EAC cable 5 m (474288A)
- APPA AirScale 2 26A DC plug 3.3-10 mm² (474281A)
- APPB AirScale 2 55A DC plug 3.3-10 mm² (474282A)
- APPC AirScale 2 55A DC plug 10-16 mm² (474283A)
- ACPA AirScale 2 Fiber Protection (474297A)

Installation options

- Pole mounting: vertical, horizontal with optional fan
- Wall mounting: vertical, horizontal with optional fan
- Compatible to RAS mounting: vertical
- Bookshelf mounting
- One-clip rail mounting



NOTICE: Install this RRH in a vertical orientation with connectors on the bottom side, to ensure convection cooling. For horizontal installation fans are required.

Dimensions and weight

Table 222 AHHB dimensions and weight

Property	Value	Dimensions orientation
Height	Core RRH: 336.7 mm (13.3 in.) With upper and lower mounting brackets: 427.5 mm (16.8 in.)	
Depth	Core RRH: 140.5 mm (5.5 in.) With mounting brackets: 164.5 mm (6.5 in.) With cover and mounting brackets: 183.5 mm (7.2 in.)	
Width	Core RRH: 295 mm (11.6 in.) With cover and mounting brackets: 322 mm (12.7 in.)	
Weight	15.7 kg (34.6 lb)	
Volume	Without cover (core only): 13.95 l	

Environmental specifications

Table 223 AHHB environmental specifications

Property	Value
Maximum operational outdoor temperature (stand-alone outdoor pole or mast)	55°C (131°F)

Table 223 AHHB environmental specifications (Cont.)

Property	Value
Maximum operational indoor and outdoor temperature (wall and shelter)	45°C (113°F)
Maximum operational indoor and outdoor temperature (with optional fan)	55°C (131°F)
Minimum operational temperature	-40°C (-40°F)
IP rating	IP65

LTE3137 feature interdependencies

The *LTE3137: Nokia AirScale RRH 4T4R B7 160 W* feature is impacted by the following features:

- *LTE112: Cell Bandwidth - 20 MHz* needs to be enabled to use LTE 20 MHz carriers.
- *LTE113: Cell Bandwidth - 15 MHz* needs to be enabled to use LTE 15 MHz carriers.
- *LTE114: Cell Bandwidth - 10 MHz* needs to be enabled to use LTE 10 MHz carriers.
- *LTE115: Cell Bandwidth - 5 MHz* needs to be enabled to use LTE 5 MHz carriers.
- With *LTE614: Distributed Site*, AHHB can be used in distributed sites with up to 23 km fiber length to the system module.
- *LTE1103: Load based Power Saving for multi-layer networks* or *LTE1203: Load based Power Saving with Tx path switching off* need to be enabled to use PA shutdown feature.
- *LTE2508: BTS Embedded Power Meter for Energy Efficiency Monitoring* needs to be enabled to use energy metering feature.
- With *LTE2541: Nokia CPRI RRH/RFM chaining*, AHHB supports Nokia CPRI chain of up to four radio units.
- *LTE2863: PIM Cancellation for AirScale 2.0 Radios* PIM Cancellation for AirScale 2.0 Radios must be enabled if the built-in PIM cancellation mechanism is to be used.
- *LTE3036: Micro DTX extension* needs to be enabled to use Micro DTX extension.

5.2.21 Nokia AirScale RRH 4T4R B5 160 W (AHCA)

AHCA is introduced by LTE3399/SR002145: Nokia AirScale RRH 4T4R B5 160 W (AHCA).

Functional description

Table 224 AHCA functional specification

Property	Value
Output power	4x40 W

Table 224 AHCA functional specification (Cont.)

Property	Value
	2x60 W
QAM	256 QAM (DL) 64 QAM (UL)
Number of TXRX	4T4R 2T4R
Outdoor installation	Yes
Supported technologies (standalone and MSR)	WCDMA, FDD-LTE, 5G-ready WCDMA-LTE
TX frequency range	869 - 894 MHz
RX frequency range	824 - 849 MHz
DL filter bandwidth	25 MHz
UL filter bandwidth	25 MHz
iBW (instantaneous bandwidth)	25 MHz
oBW (occupied bandwidth)	25 MHz
PIM cancellation	Yes
Supported bandwidths	1.4, 3, 5, 10 MHz

Interfaces

Figure 60 AHCA interfaces

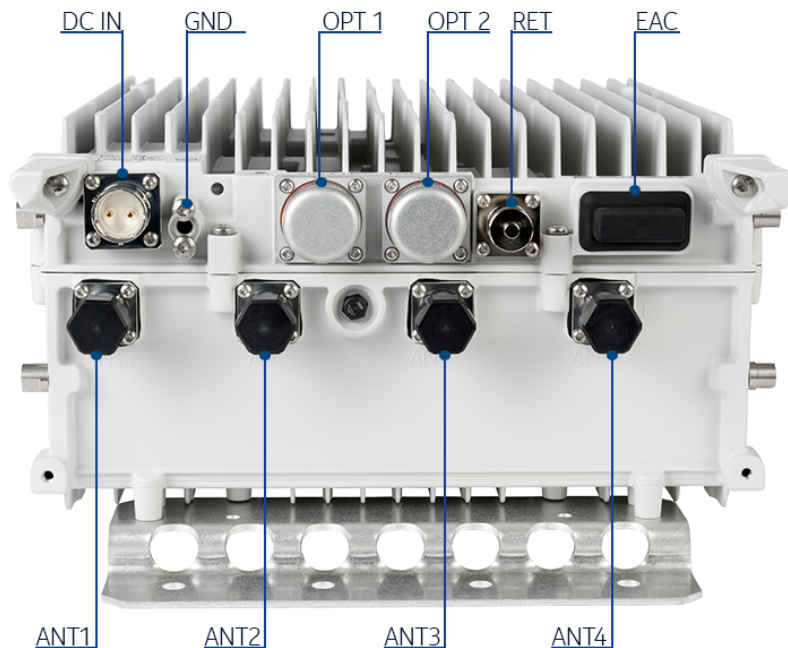



Table 225 AHCA interfaces

Interface	Label on the HW	Number of interfaces	Connector type	Additional info
Power Connector	DC IN	1	Low power circular	APPA, APPB, APPC
Antenna connector	ANT	4	4.3-10	ANT1 and ANT3 should be used with 2T4R and 2T2R modes.
Remote Electrical Tilt	RET	1	8-pin circular	RS-485
External Alarm Connection	EAC	1	MDR26	4 alarm inputs and 1 control output
Optical interface	OPT	2	Variant A (473966A): SFP+ (R2CT) Variant B (473966B): SFP+	9.8 Gbps, CPRI; Variant A (473966A): R2CT IP seal Variant B (473966B): Nokia IP seal
Ground		1	M8 or dual M5 screws	-
Fan	FAN	1	Nokia fan	Located on the opposite side

**WARNING! Risk of electric shock**

Before turning RF power on, RF ports have to be terminated by nominal 50 Ω load (for example, feeder with antenna). However, if these conditions are not met, the plastic caps that are delivered within the unused RF ports should remain in place. The plastic caps isolate RF port from the environment, and thus provide electric shock security in case RF power is accidentally on.

Antenna Line Devices (ALDs) support

Table 226 AHCA ALD support

ALD support	Value
AISG	ANT1, ANT3, RET: AISG 2.0/3.0 ANT2, ANT4: AISG 3.0 Ping receiver
CWA (for non-AISG installations)	No
Voltage	ANT1, ANT3: 14.5 V RET: 14.5 V
Power per port	ANT1, ANT3: 30 W RET: 45 W
Power	45 W

Functional block diagram

Figure 61 AHCA functional block diagram

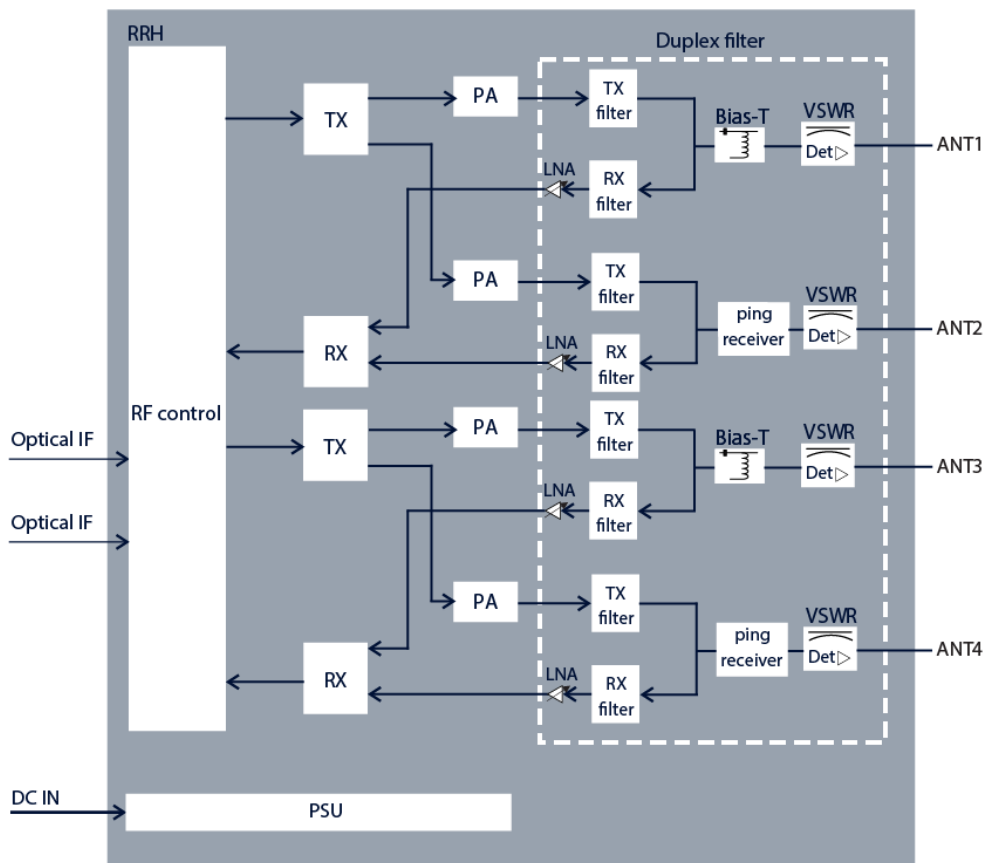

Electrical specifications

Table 227 AHCA electrical specifications

Property	Value
Nominal supply voltage	-48.0 V DC
Nominal input voltage range	-40.5 V DC to -57.0 V DC
Extended input voltage range	-36.0 V DC to -40.5 V DC -57.0 V DC to -60.0 V DC
Calculated maximum input current including tolerances	18.7 A at -36 V DC (673 W) including 45 W power feed for ALD



Note: The minimum start-up voltage is -40.5 V DC. If the input voltage is below/beyond the extended limits, the unit might shut down.

Power consumption

Typical power consumption [W] for 48VDC input, at 25°C, representative of typical product performance under the same conditions (HW variant, SW version, configuration, environment, and so on) with +/- 10% margin. Average = (6h low hour load, 10h medium hour load and 8h busy hour load) / 24h

Configurations explained on examples:

- GSM/WCDMA: 2/2/2 = three sectors, two carriers/TRXs per sector
- LTE:
 - o 2/2/2 2Tx = three sectors, two carriers per sector, 2Tx per carrier
 - o 1+1/1+1/1+1 4Tx = three dual-band sectors, one carrier per sector per band, 4Tx per carrier

Some radio units are capable of providing only one sector coverage. Then the power values in the table consider deployment of three radio units.

Table 228 AHCA power consumption in LTE mode

Configuration	Output power per carrier [W]	Power consumption ETSI 202706 average load $P_{RRH, static}$	Power consumption ETSI 202706 busy hour load $P_{BH, RRH, static}$	Power consumption 100% RF power load $P_{100\% RRH}$
1/1/1 2Tx	40+40	540	643	882
1/1/1 2Tx	60+60	722	888	1317
1/1/1 4Tx	4x20	680	794	1020
1/1/1 4Tx	4x40	860	1066	1551

Power reduction

Table 229 Recommended AHCA power reduction in 256 QAM

Single carrier [dB]	Dual carrier [dB]
0	0.8



Note: The maximum power reduction (`dlCellPwrRed`) value is 20 dB. High power reduction values may cause radio outages.

Related optional items

- ASFA AirScale 2 fan unit 300 (473968A)
- APAA AirScale AC-DC Power Unit 760W (473936A)
- AMAA AirScale 2 casing for RRH aux-units (474141A):
 - APAC AirScale AC PDU 1 to 3 (474142A)
 - APAA AirScale AC-DC Power Unit 760W (473936A) - maximum three units per one AMAA
- APAF AirScale AC-DC PSU 208-240VAC/1150 W (474676A)
- AMGE AirScale 2 cover 300 x 151-175 (474271A)
- AMBI AirScale book mount kit for AHCA (474279A)
- FPKA Flexi Pole Mounting Kit (30-120 mm) (471649A)
- FPKC Flexi Pole Mounting Kit (60-300 mm) (472821A)
- AMPA Pole Mounting Kit (30-120 mm) (473879A)
- AMFA AirScale 2 FPKx fixing adapter (474289A)
- AMFC AirScale 2 19" rack fixing 300 (474291A)

- AMFN AirScale 2 casing adapter RRH 300 (474664A)
- AMRA AirScale one clip bracket 51-125 (474580A)
- AMRC AirScale one clip rail 600 mm (474583A)
- ASAA AirScale 2 MDR26-open EAC cable 5 m (474288A)
- APPA AirScale 2 26A DC plug 3.3-10 mm² (474281A)
- APPB AirScale 2 55A DC plug 3.3-10 mm² (474282A)
- APPC AirScale 2 55A DC plug 10-16 mm² (474283A)
- ACPB AirScale 2 Fiber connector R2CT V2 (474384A)
- ACPA AirScale 2 Fiber Protection (474297A) - only if R2CT is not used

Installation options

- Wall installation
- Pole installation
- Flat mount without fans on wall or pole
- Vertical book mount without fans
- Horizontal book mount with fans
- Vertical RAS mount
- One-clip rail mounting



NOTICE: Install this RRH in a vertical orientation with connectors on the bottom side, to ensure convection cooling. For horizontal installation fans are required.

Dimensions and weight

Table 230 AHCA dimensions and weight

Property	Value	Dimensions orientation
Height	Core RRH: 386 mm (15.2 in.) With upper and lower mounting brackets: 427.5 mm (16.8 in.)	
Width	309 mm (12.1 in.) With cover: 324 mm (12.8 in.)	
Depth	Core RRH: 165 mm (6.5 in.) With mounting brackets: 189 mm (7.4 in.) With cover and mounting brackets: 208 mm (8.2 in.)	
Weight	16.7 kg (36.8 lb)	
Volume	Without cover: 16.4 l	

Environmental specifications

Table 231 AHCA environmental specifications

Property	Value
Maximum operational outdoor temperature in the shade, assuming wind speed is 3 m/s (at constant high ambient temperature, maximum output power might be limited)	55°C (131°F)
Maximum operational outdoor temperature in the sun, assuming wind speed is 3 m/s (at constant high ambient temperature, maximum output power might be limited)	50°C (122°F)
Maximum indoor temperature, assuming wind speed is 0 m/s, valid for fanless products (at constant high ambient temperature, maximum output power might be limited)	40°C (104°F)
Minimum operational temperature (including cold start)	-40°C (-40°F)
IP rating	IP65

LTE3399 feature interdependencies

The *LTE3399: Nokia AirScale RRH 4T4R B5 160 W* feature is impacted by the following features:

- *LTE114: Cell Bandwidth - 10 MHz*
needs to be enabled to use LTE 10 MHz carriers.
- *LTE115: Cell Bandwidth - 5 MHz*
needs to be enabled to use LTE 5 MHz carriers.
- *LTE116: Cell Bandwidth - 3 MHz*
needs to be enabled to use LTE 3 MHz carriers.
- *LTE117: Cell Bandwidth - 1.4 MHz*
needs to be enabled to use LTE 1.4 MHz carriers.
- With *LTE614: Distributed Site*,
AHCA can be used in distributed sites with up to 23 km fiber length to the system module.
- *LTE1103: Load based Power Saving for multi-layer networks*
needs to be enabled to use Load based Power Saving for multi-layer networks.
- *LTE1203: Load based Power Saving with Tx path switching off*
needs to be enabled to use Load based Power Saving with Tx path switching off.
- *LTE2508: BTS Embedded Power Meter for Energy Efficiency Monitoring*
needs to be enabled to use energy metering feature.
- With *LTE2541: Nokia CPRI RRH/RFM chaining*,
AHCA supports Nokia CPRI chain of up to four radio units.
- With *LTE2829: Supported RAS Installation options in FL17 Release*,
RAS installation options are defined.
- *LTE3036: Micro DTX extension*
needs to be enabled to use Micro DTX feature.

5.2.22 Nokia AirScale RRH 4T4R B26 200 W (AHCF)

AHCF is introduced by SR002703: SBTS support for MSR mode for AirScale RRH 4T4R B26 200 W AHCF.

Functional description

Table 232 AHCF functional specification

Property	Value
Output power	2x40 W + 2x60 W
QAM	256 QAM (DL) 64 QAM (UL)
Number of TXRX	4T4R
Outdoor installation	Yes
Supported technologies (standalone and MSR)	WCDMA, FDD-LTE, 5G-ready WCDMA-LTE
IoT support	NB-IoT in band, guard band (GB)
TX frequency range	859–894 MHz i Note: Due to FCC requirements 1 MHz of band 26 (859–860 MHz) is reserved for a guard band. You can allocate a carrier overlapping this area (for example 10 MHz carrier with the center frequency of 864 MHz) but in this case the overlapping PRBs need to be shut down using <i>LTE3145: Slim Carrier</i> feature.
RX frequency range	814–849 MHz
DL filter bandwidth	35 MHz
UL filter bandwidth	35 MHz
iBW (instantaneous bandwidth)	35 MHz
oBW (occupied bandwidth)	35 MHz
Number of carriers per pipe	Up to 3
Supported bandwidths	1.4, 3, 5, 10, 15 MHz
PIM cancellation	Yes

Interfaces

Figure 62 AHCF interfaces

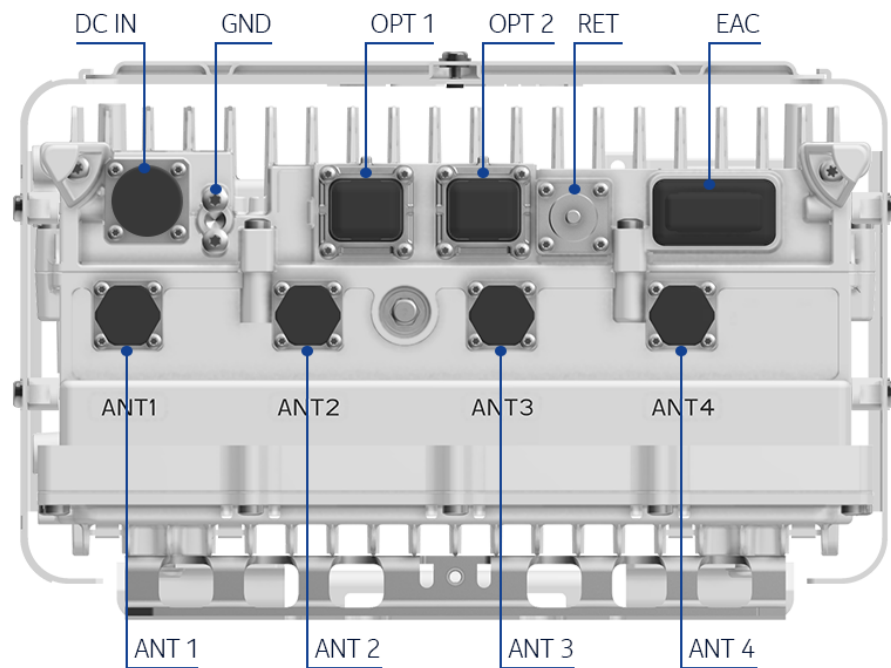

Table 233 AHCF interfaces

Interface	Label on the HW	Number of interfaces	Connector type	Additional info
Power connector	DC IN	1	Low power circular	APPA, APPB, APPC
Antenna connector	ANT	4	4.3-10	-
Remote electrical tilt	RET	1	8-pin circular	RS-485
External alarm connection	EAC	1	MDR26	4 alarm inputs and 1 control output
Optical interface	OPT	2	SFP+	9.8 Gbps, CPRI; Nokia IP seal
Grounding		1	M8 or dual M5 screws	-
Fan	FAN	1	Nokia fan	Located on the opposite side



WARNING! Risk of electric shock

Before turning RF power on, RF ports have to be terminated by nominal 50 Ω load (for example, feeder with antenna). However, if these conditions are not met, the plastic caps that are delivered within the unused RF ports should remain in place. The plastic caps isolate RF port from the environment, and thus provide electric shock security in case RF power is accidentally on.

Antenna Line Devices (ALDs) support

Table 234 AHCF ALD support

ALD support	Value
AISG	AISG 2.0/3.0 and power supply: ANT1, ANT3 PING: ANT1, ANT2, ANT3, ANT4
CWA (for non-AISG installations)	No
Voltage	14.5 V
Power per port	30 W, total 45 W

Functional block diagram

Figure 63 AHCF functional block diagram

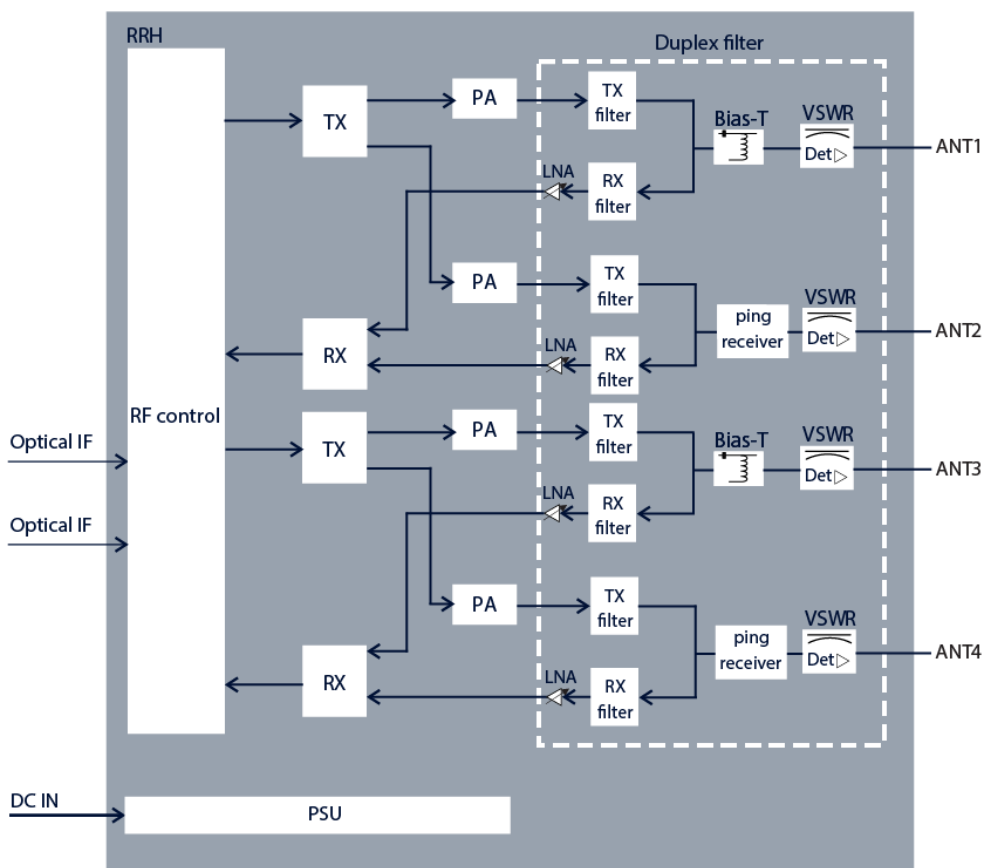

Electrical specifications

Table 235 AHCF electrical specifications

Property	Value
Nominal supply voltage	-48.0 V DC
Nominal input voltage range	-40.5 V DC to -57.0 V DC
Extended input voltage range	-36.0 V DC to -40.5 V DC -57.0 V DC to -60.0 V DC



Note: The minimum start-up voltage is –40.5 V DC. If the input voltage is below/beyond the extended limits, the unit might shut down.

Power consumption



Note: AHCF power consumption will be provided in future releases.

Power reduction



Note: The maximum power reduction (`dlCellPwrRed`) value is 20 dB. High reduction values may cause radio outages.

Related optional items

- ASFA AirScale 2 fan unit 300 (473968A)
- APAA AirScale AC-DC Power Unit 760W (473936A)
- AMAA AirScale 2 casing for RRH aux-units (474141A):
 - APAC AirScale AC PDU 1 to 3 (474142A)
 - APAA AirScale AC-DC Power Unit 760W (473936A) - maximum three units per one AMAA
- APAF AirScale AC-DC PSU 208-240VAC/1150 W (474676A)
- AMBI AirScale book mount kit for AHCA (474279A)
- FPKA Flexi Pole Mounting Kit (30-120 mm) (471649A)
- FPKC Flexi Pole Mounting Kit (60-300 mm) (472821A)
- AMPA Pole Mounting Kit (30-120 mm) (473879A)
- AMFA AirScale 2 FPKx fixing adapter (474289A)
- AMFC AirScale 2 19" rack fixing 300 (474291A)
- AMFN AirScale 2 casing adapter RRH 300 (474664A)
- AMRA AirScale one clip bracket 51-125 (474580A)
- AMRC AirScale one clip rail 600 mm (474583A)
- ASAA AirScale 2 MDR26-open EAC cable 5 m (474288A)
- APPA AirScale 2 26A DC plug 3.3-10 mm² (474281A)
- APPB AirScale 2 55A DC plug 3.3-10 mm² (474282A)
- APPC AirScale 2 55A DC plug 10-16 mm² (474283A)
- ACPA AirScale 2 Fiber Protection (474297A)

Installation options

- Pole: vertical, horizontal with an optional fan
- Wall: vertical, horizontal with an optional fan
- Vertical RAS mounting
- Book mounting
- One-clip rail mounting



NOTICE: Install this RRH in a vertical orientation with connectors on the bottom side, to ensure convection cooling. For horizontal installation fans are required.

Dimensions and weight

Table 236 AHCF dimensions and weight

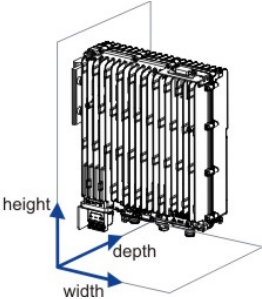
Property	Value	Dimensions orientation
Height	Core RRH with ID cover: 372.5mm (14.67 in) With upper and lower mounting brackets: 447.5mm (17.62 in)	
Width	Core RRH with ID cover: 317 mm (12.4 in)	
Depth	Core RRH with ID cover: 185 mm (7.28 in) With upper and lower mounting brackets: 198.5 mm (7.81 in)	
Weight	Core RRH with ID cover: 19.2 kg (42.3 lb) With upper and lower mounting brackets: 20.5 kg (45.2 lb)	
Volume	Core RRH with ID cover: 21.8 l	

Environmental specifications

Table 237 AHCF environmental specifications

Property	Value
Maximum operational outdoor temperature (in the shade)	55°C (131°F)
Maximum operational outdoor temperature (in the sun)	55°C (131°F)
Maximum indoor temperature	45°C (113°F)
Minimum operational temperature	-40°C (-40°F)
IP rating	IP65

SR002703 feature interdependencies

The SR002703: SBTS support for MSR mode for AirScale RRH 4T4R B26 200 W AHCF feature is impacted by the following features:

- LTE113: Cell Bandwidth - 15 MHz enables LTE 15 MHz carriers.
- LTE114: Cell Bandwidth - 10 MHz enables LTE 10 MHz carriers.
- LTE115: Cell Bandwidth - 5 MHz enables LTE 5 MHz carriers.
- LTE116: Cell Bandwidth - 3 MHz enables LTE 3 MHz carriers.
- LTE117: Cell Bandwidth - 1.4 MHz enables LTE 1.4 MHz carriers.
- With LTE614: Distributed Site, AHCF can be used in distributed sites with up to 23 km (14.29 mi) fiber length to the system module.
- With LTE2541: Nokia CPRI RRH/RFM chaining, AHCF supports Nokia CPRI chain of up to four radio units.
- Power saving features:

- LTE1103: Load based Power Saving for multi-layer networks
- LTE1203: Load based Power Saving with Tx path switching off
- LTE2508: BTS Embedded Power Meter for Energy Efficiency Monitoring
- LTE3036: Micro DTX extension

5.2.23 Nokia AirScale RRH 4T4R B26a 100 W (AHCC)

AHCC is introduced by LTE4260: Nokia AirScale RRH 4T4R B26a 100 W (AHCC).

Functional description

Table 238 AHCC functional specification

Property	Value
Output power	2x40 W 4x25 W
QAM	256 QAM (DL) 64 QAM (UL)
Number of TXRX	4T4R
Outdoor installation	Yes
Supported technologies (standalone and MSR)	FDD-LTE, 5G-ready
IoT support	NB-IoT in band, guard band (GB), standalone (SA)
TX frequency range	862.6 – 869 MHz
RX frequency range	817.6 – 824 MHz
DL filter bandwidth	6.4 MHz
UL filter bandwidth	6.4 MHz
iBW (instantaneous bandwidth)	6.4 MHz
oBW (occupied bandwidth)	6.4 MHz
Number of carriers per pipe	Up to 3
Supported bandwidths	1.4, 3, 5 MHz
PIM cancellation	No

Interfaces

Figure 64 AHCC interfaces

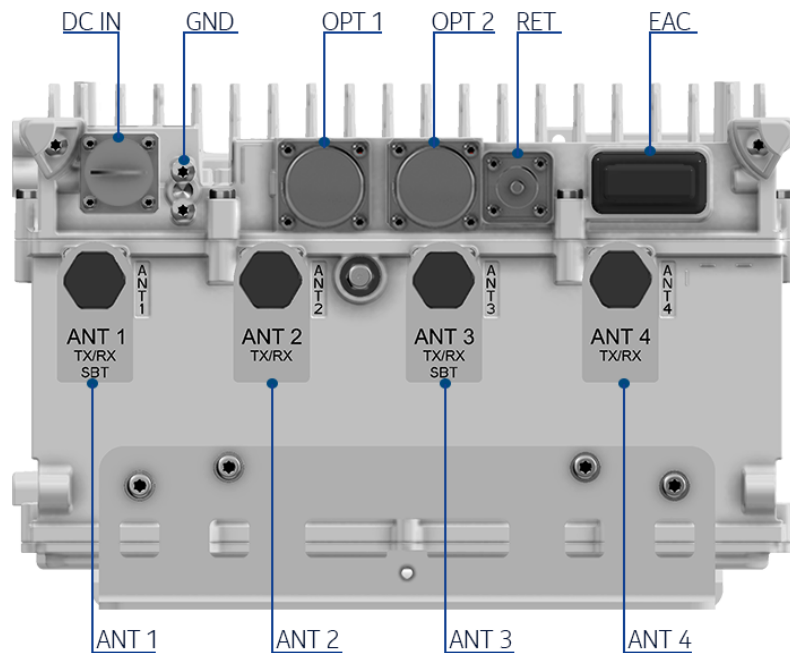

Table 239 AHCC interfaces

Interface	Label on the HW	Number of interfaces	Connector type	Additional info
Power Connector	DC IN	1	Two position circular connector	APPA, APPB, APPC
Antenna connector	ANT	4	4.3-10 Plus	AISG & BiasT support on ANT1 and ANT3
Remote Electrical Tilt	RET	1	8-pin circular	RS-485
External Alarm Connection	EAC	1	MDR26	4 alarm inputs and 1 control output
Optical interface	OPT	2	SFP+	9.8 Gbps, CPRI; R2CT IP caps
Grounding		1	M8 or dual M5 screws	-
Fan	FAN	1	Nokia fan	Located on the opposite side



WARNING! Risk of electric shock

Before turning RF power on, RF ports have to be terminated by nominal 50 Ω load (for example, feeder with antenna). However, if these conditions are not met, the plastic caps that are delivered within the unused RF ports should remain in place. The plastic caps isolate RF port from the environment, and thus provide electric shock security in case RF power is accidentally on.

Antenna Line Devices (ALDs) support

Table 240 AHCC ALD support

ALD support	Value
AISG	ANT1, ANT3: AISG 2.0/3.0 ANT2, ANT4: AISG 3.0 ping receiver RET: AISG 2.0/3.0
Voltage	ANT1, ANT3, RET: 14.5 V
Power per port	30 W, 45 W total

Functional block diagram

Figure 65 AHCC functional block diagram

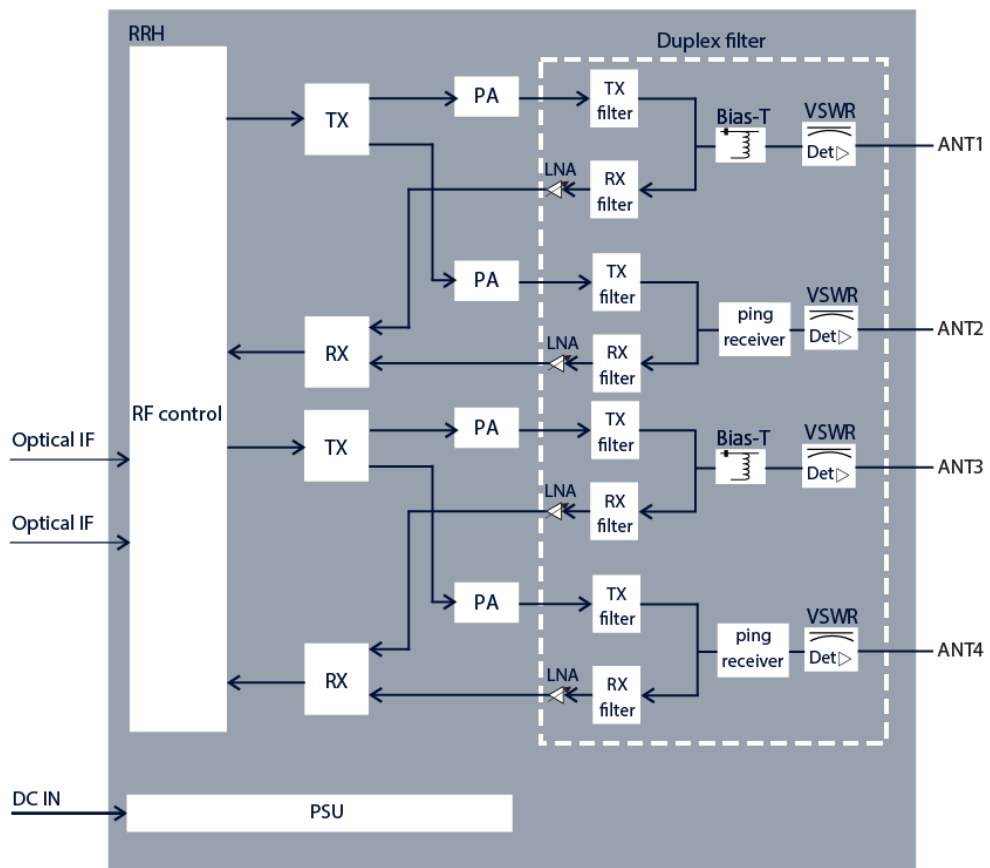

Electrical specifications

Table 241 AHCC electrical specifications

Property	Value
Nominal supply voltage	-48.0 V DC
Nominal input voltage range	-40.5 V DC to -57.0 V DC
Extended input voltage range	-36.0 V DC to -40.5 V DC -57.0 V DC to -60.0 V DC



Note: The minimum start-up voltage is -40.5 V DC. If the input voltage is below/beyond the extended limits, the unit might shut down.

Table 242 AHCC TX output power tolerance

Property	Tolerance	Description
Typical power tolerance (nominal temperature)	± 0.8dB	Over full TX RF bandwidth, nominal ambient temperature 25°C (77°F)
Typical power tolerance (extreme temperature)	± 2.0dB	Over full TX RF bandwidth, extreme ambient temperature 55°C (131°F)
Typical power tolerance for Standalone NB-IoT (nominal temperature)	± 2.0dB	Over full TX RF bandwidth, nominal ambient temperature 25°C (77°F)
Typical power tolerance for Standalone NB-IoT (nominal temperature)	± 2.5dB	Over full TX RF bandwidth, extreme ambient temperature 55°C (131°F)

Power consumption

Typical power consumption [W] for 48VDC input, at 25°C, representative of typical product performance under the same conditions (HW variant, SW version, configuration, environment, and so on) with +/- 10% margin. Average = (6h low hour load, 10h medium hour load and 8h busy hour load) / 24h

Table 243 AHCC power consumption in LTE mode

Property	Value
Typical power consumption (4x25 W/2x40 W output power)	259/217W (ETSI 24h average)
Maximum power consumption (4x25 W/2x40 W output power)	422/340W (Typical, 100% load)

Power reduction

Table 244 AHCC power reduction in 256 QAM

Rated power [W]	Single Carrier [dB]	Dual Carrier [dB]	Triple Carrier [dB]
40	0	0.4	0.4
25	0	0	0.4



Note: Final values will be provided in future releases.



Note: The maximum power reduction (dlCellPwrRed) value is 20 dB. High power reduction values may cause radio outages.

Related optional items

- ASFA AirScale 2 fan unit 300 (473968A)
- APAA AirScale AC-DC Power Unit 760W (473936A)
- AMAA AirScale 2 casing for RRH aux-units (474141A):

- APAC AirScale AC PDU 1 to 3 (474142A)
- APAA AirScale AC-DC Power Unit 760W (473936A) - maximum three units per one AMAA
- AMGF AirScale2 cover 300 x 176-200 (474272A)
- FPKA Flexi Pole Mounting Kit (30-120 mm) (471649A)
- FPKC Flexi Pole Mounting Kit (60-300 mm) (472821A)
- AMFA AirScale 2 FPKx fixing adapter (474289A)
- AMFC AirScale 2 19" rack fixing 300 (474291A)
- AMRB AirScale one clip bracket 126-200 (474581A)
- AMRC AirScale one clip rail 600 mm (474583A)
- ASAA AirScale 2 MDR26-open EAC cable 5 m (474288A)
- APPA AirScale 2 26A DC plug 3.3-10 mm² (474281A)
- APPB AirScale 2 55A DC plug 3.3-10 mm² (474282A)
- APPC AirScale 2 55A DC plug 10-16 mm² (474283A)
- ACPB AirScale 2 Fiber connector R2CT V2 (474384A)

Installation options

- Wall installation
- Pole installation
- Flat mount without fans on wall or pole
- Vertical book mount without fans
- Horizontal book mount with fans



NOTICE: Install this RRH in a vertical orientation with connectors on the bottom side, to ensure convection cooling. For horizontal installation fans are required.

Dimensions and weight

Table 245 AHCC dimensions and weight

Property	Value	Dimensions orientation
Height	337 mm (13.26 in.) With upper and lower mounting bracket: 427.5 mm (16.83 in.)	
Depth	190 mm (7.48 in.) With upper and lower mounting bracket: 206.5 mm (8.12 in.)	
Width	295 mm (11.61 in.)	
Weight	21.5 kg (47.4 lb)	

Environmental specifications

Table 246 AHCC environmental specifications

Property	Value
Maximum operational outdoor temperature in the shade, assuming wind speed is 3 m/s (at constant high ambient temperature, maximum output power might be limited)	55°C (131°F)
Maximum operational outdoor temperature in the sun, assuming wind speed is 3 m/s (at constant high ambient temperature, maximum output power might be limited)	55°C (131°F)
Maximum indoor temperature, assuming wind speed is 0 m/s, valid for fanless products (at constant high ambient temperature, maximum output power might be limited)	45°C (113°F)
Minimum operational temperature (including cold start)	-40°C (-40°F)
IP rating	IP65

LTE4260 feature interdependencies

The *LTE4260: Nokia AirScale RRH 4T4R B26a 100 W (AHCC)* feature is impacted by the following features:

- *LTE115: Cell Bandwidth - 5 MHz* needs to be enabled to use LTE 5 MHz carriers.
- *LTE116: Cell Bandwidth - 3 MHz* needs to be enabled to use LTE 3 MHz carriers.
- *LTE117: Cell Bandwidth - 1.4 MHz* needs to be enabled to use LTE 1.4 MHz carriers.
- With *LTE614: Distributed Site*, AHCC can be used in distributed sites with up to 23 km fiber length to the system module.
- *LTE1103: Load based Power Saving for multi-layer networks* needs to be enabled to use Load based Power Saving for multi-layer networks.
- *LTE1203: Load based Power Saving with Tx path switching off* needs to be enabled to use Load based Power Saving with Tx path switching off.
- *LTE2508: BTS Embedded Power Meter for Energy Efficiency Monitoring* needs to be enabled to use energy metering feature.
- With *LTE2541: Nokia CPRI RRH/RFM chaining*, AHCC supports Nokia CPRI chain of up to four radio units.
- *LTE3036: Micro DTX extension* needs to be enabled to use Micro DTX feature.

5.2.24 Nokia AirScale RRH 4T4R B28/n28 320 W (AHPB)

AHPB (474119A) is introduced by LTE3651/5GC000930: Nokia AirScale RRH 4T4R B28/n28 320 W AHPB.

Functional description

Table 247 AHPB functional specification

Property	Value
Output power	4x80 W
QAM	256 QAM (DL) 64 QAM (UL)
Number of TXRX	4T4R
Outdoor installation	Yes
Supported technologies (standalone and MSR)	FDD-LTE, 5G
TX frequency range	758 to 803 MHz
RX frequency range	703 to 748 MHz
DL filter bandwidth	45 MHz
UL filter bandwidth	45 MHz
iBW (instantaneous bandwidth)	45 MHz
oBW (occupied bandwidth)	45 MHz
Number of carriers per pipe	Up to 4 carriers in total for all supported RATs
Supported bandwidths	LTE: 3, 5, 10, 15, 20 MHz 5G: 5, 10, 15, 20 MHz
PIM cancellation	Yes

Interfaces

Figure 66 AHPB interfaces

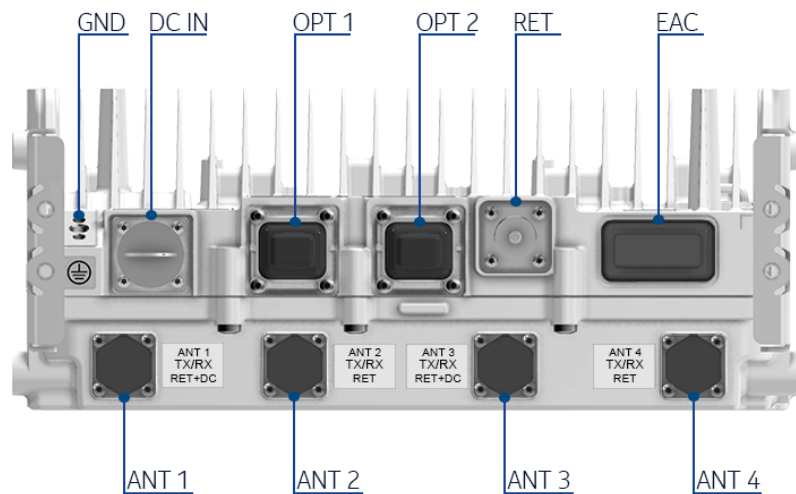



Table 248 AHPB interfaces

Interface	Label on the HW	Number of interfaces	Connector type	Additional info
Power Connector	DC IN	1	high power circular	APPB, APPC
Antenna connector	ANT	4	4.3-10	-
Remote Electrical Tilt	RET	1	8-pin circular	RS-485
External Alarm Connection	EAC	1	MDR26	4 alarm inputs and 1 control output
Optical interface	OPT	2	SFP+	9.8 Gbps, CPRI; Nokia IP seal
Grounding		1	M8 or dual M5 screws	-
Fan	FAN	1	Nokia fan	Located on the heat sink side



WARNING! Risk of electric shock

Before turning RF power on, RF ports have to be terminated by nominal 50 Ω load (for example, feeder with antenna). However, if these conditions are not met, the plastic caps that are delivered within the unused RF ports should remain in place. The plastic caps isolate RF port from the environment, and thus provide electric shock security in case RF power is accidentally on.

Antenna Line Devices (ALDs) support

Table 249 AHPB ALD support

ALD support	Value
AISG	2.0, 3.0
CWA (for non-AISG installations)	No
Voltage	14.5 V (ANT1 and ANT3 only)
Power per port	30 W, 45 W total

Functional block diagram

Figure 67 AHPB functional block diagram

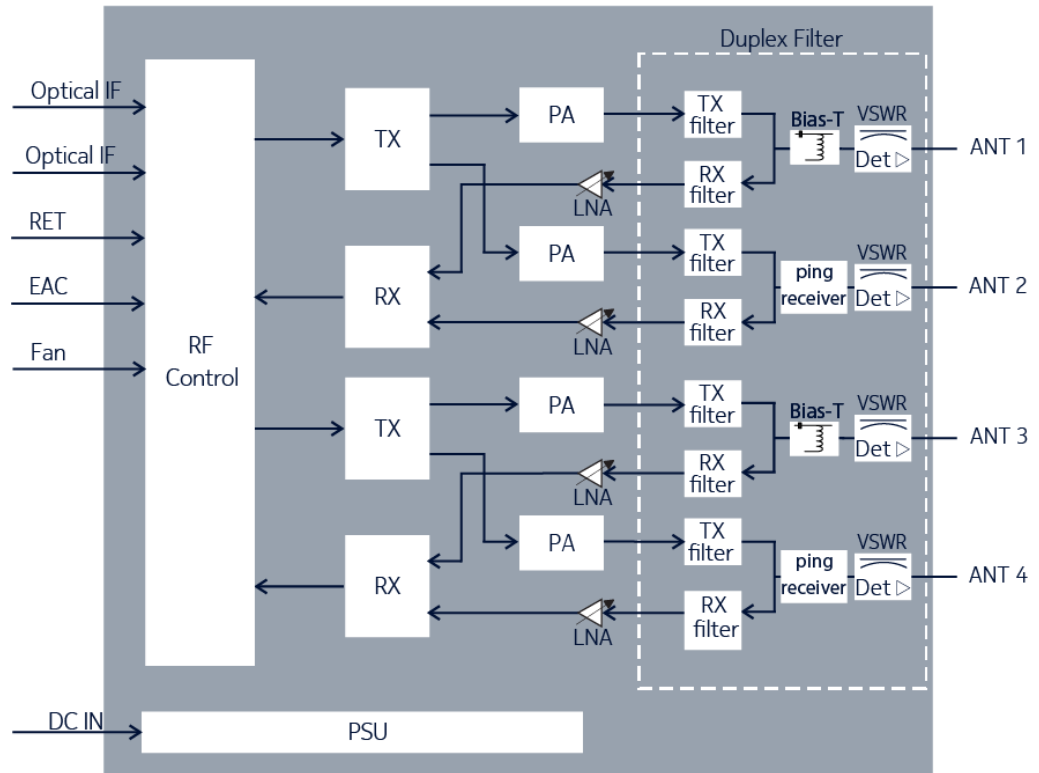

Electrical specifications

Table 250 AHPB electrical specifications

Property	Value
Nominal supply voltage	-48.0 V DC
Nominal input voltage range	-40.5 V DC to -57.0 V DC
Extended input voltage range	-36.0 V DC to -40.5 V DC -57.0 V DC to -60.0 V DC



Note: The minimum start-up voltage is -40.5 V DC. If the input voltage is below/beyond the extended limits, the unit might shut down.

Power consumption

Typical power consumption [W] for 48VDC input, at 25°C, representative of typical product performance under the same conditions (HW variant, SW version, configuration, environment, and so on) with +/- 10% margin. Average = (6h low hour load, 10h medium hour load and 8h busy hour load) / 24h

Configurations explained on examples:

- GSM/WCDMA: 2/2/2 = three sectors, two carriers/TRXs per sector
- LTE:
 - o 2/2/2 2Tx = three sectors, two carriers per sector, 2Tx per carrier

o 1+1/1+1/1+1 4Tx = three dual-band sectors, one carrier per sector per band, 4Tx per carrier

Some radio units are capable of providing only one sector coverage. Then the power values in the table consider deployment of three radio units.

Table 251 AHPB power consumption in LTE mode

Configuration	Output power per carrier [W]	Power consumption ETSI 202706 average P_{RRH} , static	Power consumption ETSI 202706 busy hour load $P_{BH\ RRH}$, static	Power consumption 100% RF power load $P_{100\% \ RRH}$
1/1/1 4Tx	4 x 80	1531	1982	3029
1/1/1 4Tx	4 x 60	1358	1702	2492
1/1/1 4Tx	4 x 40	1167	1397	1913
1/1/1 4Tx	4 x 20	980	1104	1368
1/1/1 2Tx	2 x 80	931	1152	1649
1/1/1 2Tx	2 x 60	844	1010	1391
1/1/1 2Tx	2 x 40	752	864	1118
1/1/1 2Tx	2 x 20	661	720	847

Power reduction

Table 252 AHPB power reduction in 256 QAM (carrier spacing over 100 MHz)

Single carrier [dB]	Dual carrier [dB]	Triple [dB]	Quad [dB]
0.8	1.4	1.4	1.6



Note: The maximum power reduction ($dlCellPwrRed$) value is 20 dB. High power reduction values may cause radio outages.

Related optional items

- ASFC AirScale 2 fan unit 600 (474484A)
- AMBF AirScale book mount kit 126-150 (474278A)
- FPKA Flexi Pole Mounting Kit (30-120 mm) (471649A)
- FPKC Flexi Pole Mounting Kit (60-300 mm) (472821A)
- AMPA Pole Mounting Kit (30-120 mm) (473879A)
- AMFD AirScale 2 FPKx Fixing Adapter 600 (474293A)
- ASAA AirScale 2 MDR26-open EAC cable 5 m (474288A)
- APPB AirScale 2 55A DC plug 3.3-10 mm² (474282A)
- APPC AirScale 2 55A DC plug 10-16 mm² (474283A)
- ACPA AirScale 2 Fiber Protection (474297A)
- AMRB AirScale one clip bracket 126-200 (474581A)
- AMRC AirScale one clip rail 600 mm (474583A)

Installation options

- Wall installation
- Pole installation
- Vertical book mount
- Horizontal book mount (fan is required)



NOTICE: Install this RRH in a vertical orientation with connectors on the bottom side, to ensure convection cooling. For horizontal installation fans are required.

Dimensions and weight

Table 253 AHPB dimensions and weight

Property	Value	Dimensions orientation
Height	Core RRH: 512 mm (20.2 in.) With upper and lower mounting brackets: 630 mm (24.8 in.)	
Width	Core RRH: 308 mm (12.1 in.) With side mounting bosses: 321 mm (12.6 in.)	
Depth	Core RRH: 130 mm (5.1 in.) With mounting brackets: 142 mm (5.6 in.)	
Weight	24 kg (52.9 lb)	

Environmental specifications

Table 254 AHPB environmental specifications

Property	Value
Maximum operational outdoor temperature (in the shade) with fan or 10.8 km/h (6.7 mph) wind	55°C (131°F)
Maximum operational outdoor temperature (in the sun) with fan or 10.8 km/h (6.7 mph) wind	50°C (122°F)
Maximum indoor temperature	45°C (113°F)
Minimum operational temperature	-40°C (-40°F)
IP rating	IP65

LTE3651 feature interdependencies

The *LTE3651: Nokia AirScale RRH 4T4R B28 320 W* feature is impacted by the following features:

- *LTE112: Cell Bandwidth - 20 MHz* needs to be enabled to use LTE 20 MHz carriers.
- *LTE113: Cell Bandwidth - 15 MHz* needs to be enabled to use LTE 15 MHz carriers.

- *LTE114: Cell Bandwidth - 10 MHz* needs to be enabled to use LTE 10 MHz carriers.
- *LTE115: Cell Bandwidth - 5 MHz* needs to be enabled to use LTE 5 MHz carriers.
- *LTE116: Cell Bandwidth - 3 MHz* needs to be enabled to use LTE 3 MHz carriers.
- *WithLTE614: Distributed Site*, can be used in distributed sites with up to 23 km fiber length to the system module.
- *LTE1103: Load based Power Saving for multi-layer networks* or *LTE1203: Load based Power Saving with Tx path switching off* need to be enabled to use PA shutdown feature.
- *LTE2508: BTS Embedded Power Meter for Energy Efficiency Monitoring* needs to be enabled to use energy metering feature.
- *WithLTE2541: Nokia CPRI RRH/RFM chaining*, AHPB supports Nokia CPRI chain of up to four radio units.
- *LTE3036: Micro DTX extension* needs to be enabled to use Micro DTX extension.

5.2.25 Nokia AirScale RRH 4T4R B30 100 W (AHNA)

AHNA is introduced by LTE4637/SR002150: AirScale RRH 4T4R B30 100 W AHNA.

Functional description

Table 255 AHNA functional specification

Property	Value
Output power	4x25 W
QAM	256 QAM (DL) 64 QAM (UL)
Number of TXRX	4T4R
Outdoor installation	Yes
Supported technologies (standalone and MSR)	FDD-LTE, 5G-ready
IoT support	NB-IoT in band, guard band (GB), standalone (SA)
TX frequency range	2350 – 2360 MHz
RX frequency range	2305 – 2315 MHz
DL filter bandwidth	10 MHz
UL filter bandwidth	10 MHz
iBW (instantaneous bandwidth)	10 MHz
oBW (occupied bandwidth)	10 MHz
Number of carriers per pipe	Up to 2
Supported bandwidths	5, 10 MHz
PIM cancellation	Yes

Interfaces

Figure 68 AHNA interfaces

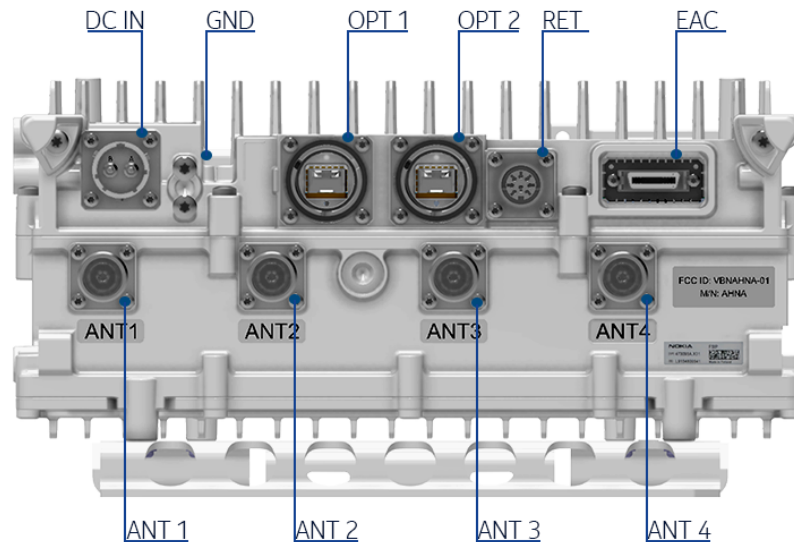

Table 256 AHNA interfaces

Interface	Label on the HW	Number of interfaces	Connector type	Additional info
Power Connector	DC IN	1	Low power circular	APPA, APPB, APPC
Antenna connector	ANT	4	4.3-10	-
Remote Electrical Tilt	RET	1	8-pin circular	RS-485
External Alarm Connection	EAC	1	MDR 26	4 alarm inputs and 1 control output
Optical interface	OPT	2	SFP+	9.8 Gbps, CPRI; R2CT IP seal
Grounding		1	M8 or dual M5 screws	-
Fan	FAN	1	Nokia fan	Located on the opposite side



WARNING! Risk of electric shock

Before turning RF power on, RF ports have to be terminated by nominal 50 Ω load (for example, feeder with antenna). However, if these conditions are not met, the plastic caps that are delivered within the unused RF ports should remain in place. The plastic caps isolate RF port from the environment, and thus provide electric shock security in case RF power is accidentally on.

Antenna Line Devices (ALDs) support

Table 257 AHNA ALD support

ALD support	Value
AISG	ANT1, ANT3, RET: AISG 3.0 ANT2, ANT4: AISG 3.0 Ping receiver
CWA (for non-AISG installations)	No
Voltage	ANT1, ANT3, RET: 14.5 V
Power per port	ANT1, ANT3: 30 W RET: 45 W
Total maximum power	45 W

Functional block diagram

Figure 69 AHNA functional block diagram

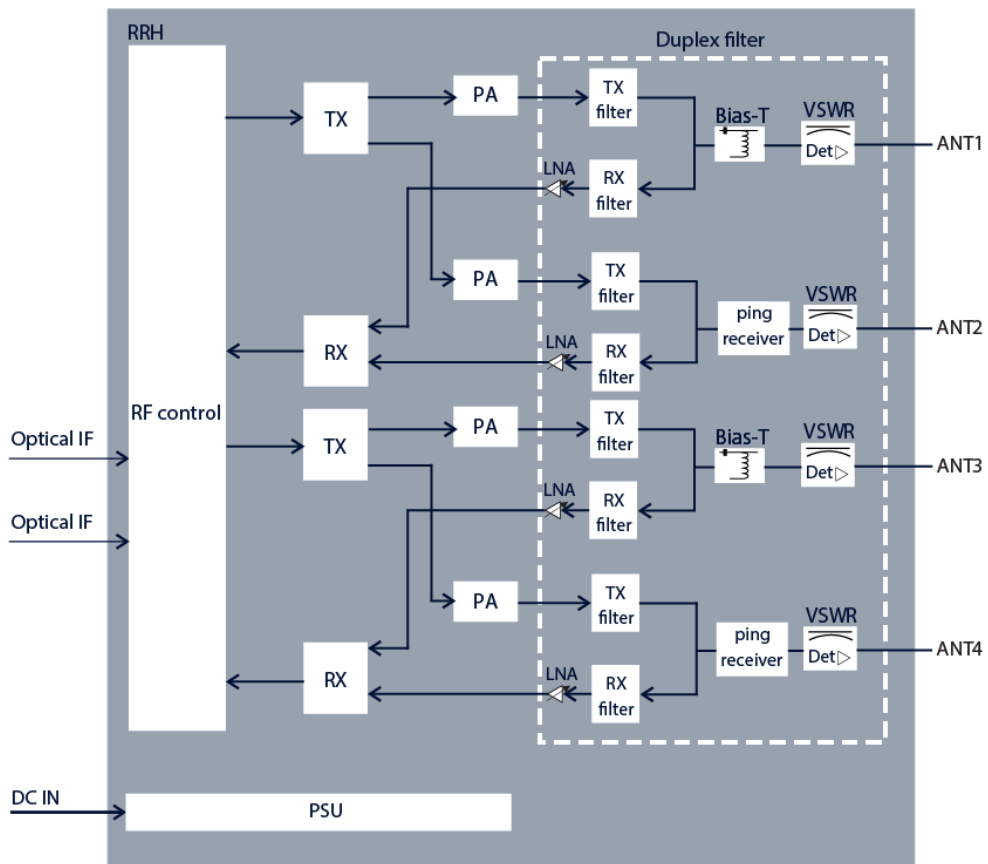

Electrical specifications

Table 258 AHNA electrical specifications

Property	Value
Nominal supply voltage	-48.0 V DC
Nominal input voltage range	-40.5 V DC to -57.0 V DC

Table 258 AHNA electrical specifications (Cont.)

Property	Value
Extended input voltage range	-36.0 V DC to -40.5 V DC
	-57.0 V DC to -60.0 V DC



Note: The minimum start-up voltage is -40.5 V DC. If the input voltage is below/beyond the extended limits, the unit might shut down.

Power consumption

Typical power consumption [W] for 48VDC input, at 25°C, representative of typical product performance under the same conditions (HW variant, SW version, configuration, environment, and so on) with +/- 10% margin. Average = (6h low hour load, 10h medium hour load and 8h busy hour load) / 24h

Configurations explained on examples:

- GSM/WCDMA: 2/2/2 = three sectors, two carriers/TRXs per sector
- LTE:
 - o 2/2/2 2Tx = three sectors, two carriers per sector, 2Tx per carrier
 - o 1+1/1+1/1+1 4Tx = three dual-band sectors, one carrier per sector per band, 4Tx per carrier

Some radio units are capable of providing only one sector coverage. Then the power values in the table consider deployment of three radio units.

Table 259 AHNA power consumption in LTE mode

Configuration	Output Power per carrier (W)	Power consumption (W), ETSI 202706 average load P_{RRH} , static	Power consumption (W), ETSI 202706 busy hour load P_{BH} $_{RRH}$, static	Power consumption (W), 100% RF power load $P_{100\% RRH}$
1/1/1 4Tx	4x25	783	965	1403
1/1/1 2Tx	2x25	494	581	785

Power reduction

Table 260 AHNA power reduction in 256QAM

Single carrier [dB]	Dual carrier [dB]
0.5 dB	1 dB



Note: The maximum power reduction ($d1CellPwrRed$) value is 20 dB. High power reduction values may cause radio outages.

Related optional items

- ASFA AirScale 2 fan unit 300 (473968A)
- APAA AirScale AC-DC Power Unit 760W (473936A)
- AMAA AirScale 2 casing for RRH aux-units (474141A):

- APAC AirScale AC PDU 1 to 3 (474142A)
- APAA AirScale AC-DC Power Unit 760W (473936A) - maximum three units per one AMAA
- AMGD AirScale 2 cover 300 x 126-150 (474270A)
- AMBF Book Mount Kit 126-150 (474278A)
- FPKA Flexi Pole Mounting Kit (30-120 mm) (471649A)
- FPKC Flexi Pole Mounting Kit (60-300 mm) (472821A)
- AMPA Pole Mounting Kit (30-120 mm) (473879A)
- AMFA AirScale 2 FPKx fixing adapter (474289A)
- AMFB AirScale2 RAS2 fixing kit 300 mm (474290A)
- AMFC AirScale 2 19" rack fixing 300 (474291A)
- AMFN AirScale 2 casing adapter RRH 300 (474664A)
- AMRA AirScale one clip bracket 51-125 (474580A)
- AMRC AirScale one clip rail 600 mm (474583A)
- ASAA AirScale 2 MDR26-open EAC cable 5 m (474288A)
- APPA AirScale 2 26A DC plug 3.3-10 mm² (474281A)
- APPB AirScale 2 55A DC plug 3.3-10 mm² (474282A)
- APPC AirScale 2 55A DC plug 10-16 mm² (474283A)
- ACPB AirScale 2 Fiber connector R2CT V2 (474384A)

Installation options

- Pole/wall mounting
- Vertical book mounting (without fans)
- Vertical RAS2.0 (with fans)
- Horizontal book mounting (with fans)
- One-clip rail mounting



NOTICE: Install this RRH in a vertical orientation with connectors on the bottom side, to ensure convection cooling. For horizontal installation fans are required.

Dimensions and weight

Table 261 AHNA dimensions and weight

Property	Value	Dimensions orientation
Height	Core RRH: 336.5 mm (13.25 in.) With upper and lower mounting brackets 427.5 mm (16.83 in.)	
Depth	Core RRH: 140 mm (5.51 in.) With mounting brackets: 164 mm (6.46 in.) With cover and mounting brackets: 183 mm (7.21 in.)	

Table 261 AHNA dimensions and weight (Cont.)

Property	Value	Dimensions orientation
Width	Core RRH: 306 mm (12.05 in.) With cover: 324 mm (12.76 in.)	
Weight	Core RRH: 15.5 kg (34.2 lb) Core with brackets and cover: 17.7 kg (39.0 lb)	
Volume	Core RRH: 14.4 l	

Environmental specifications

Table 262 AHNA environmental specifications

Property	Value
Maximum operational outdoor temperature in the shade, assuming wind speed is 3 m/s (at constant high ambient temperature, maximum output power might be limited)	55°C (131°F)
Maximum operational outdoor temperature in the sun, assuming wind speed is 3 m/s (at constant high ambient temperature, maximum output power might be limited)	50°C (122°F)
Maximum indoor temperature, assuming wind speed is 0 m/s, valid for fanless products (at constant high ambient temperature, maximum output power might be limited)	40°C (104°F)
Minimum operational temperature (including cold start)	-40°C (-40°F)
IP rating	IP65

LTE4637 feature interdependencies

The *LTE4637/SR002150: AirScale RRH 4T4R B30 100W AHNA* feature is impacted by the following features:

- *LTE115: Cell Bandwidth - 5 MHz* needs to be enabled to use LTE 5 MHz carriers.
- *LTE114: Cell Bandwidth - 10 MHz* needs to be enabled to use LTE 10 MHz carriers.
- With *LTE614: Distributed Site*, AHNA can be used in distributed sites with up to 23 km fiber length to the system module.
- With *LTE2541: Nokia CPRI RRH/RFM chaining*, AHNA supports Nokia CPRI chain of up to four radio units.
- *LTE2508: BTS Embedded Power Meter for Energy Efficiency Monitoring* needs to be enabled to use the energy-metering feature.
- *LTE1103: Load based Power Saving for multi-layer networks* needs to be enabled to use the Load-based Power Saving for multi-layer networks.
- *LTE1203: Load based Power Saving with Tx path switching off* needs to be enabled to use the Load based Power Saving with Tx path switching off.
- *LTE3036: Micro DTX extension* needs to be enabled to use the Micro DTX feature.

- With *LTE2541: Nokia CPRI RRH/RFM chaining*, AHNA supports Nokia CPRI chain of up to four radio units.

5.2.26 Nokia AirScale RRH 4T4R B66/n66 160 W (FRIJ)

FRIJ is introduced by LTE2516/SR001361/5GC002309: Nokia AirScale RRH 4T4R B66/n66 160 W (FRIJ).

Functional description

Table 263 FRIJ functional specification

Property	Value
Output power	4x40 W
Output power of the cell per TX	39 to 46 dBm with 0.1 dB steps
QAM	64 QAM (UL and DL)
Number of TXRX	4T4R
Outdoor installation	Yes
Supported technologies (standalone and MSR)	WCDMA, FDD-LTE, 5G NR LTE-WCDMA
TX frequency range	2110-2200 MHz
RX frequency range	1710-1780 MHz
DL filter bandwidth	90 MHz
UL filter bandwidth	70 MHz
DL iBW (instantaneous bandwidth)	90 MHz
UL iBW (instantaneous bandwidth)	70 MHz
oBW (occupied bandwidth)	40 MHz
Number of carriers per pipe	Up to 4
Supported bandwidths	LTE, 5G: 5, 10, 15, 20 MHz WCDMA: 3.8, 4.2, 5 MHz

Interfaces

Figure 70 FRIJ interfaces

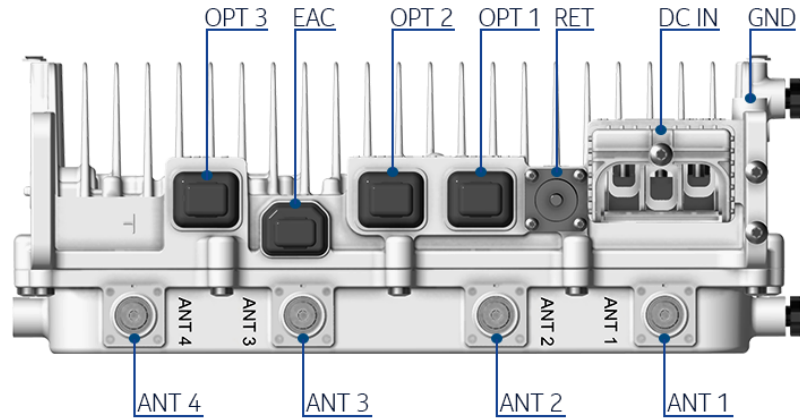



Table 264 FRIJ interfaces

Interface	Label on the HW	Number of interfaces	Connector type	Additional info
Power Connector	DC IN	1	3-pole screw terminal	-
Antenna connector	ANT	4	4.3-10	-
Remote Electrical Tilt	RET	1	AISG C485	8-pin circular
External Alarm Connection	EAC	1	USB 3.0 Type-A	4 alarm inputs and 1 control output
Optical interface	OPT	3	SFP+	6 Gbps, OBSAI, Nokia IP seal
Ground		1	M8 or dual M5 screws	-
Fan	Fan	1	2-pin Micro-Fit	Located on the side of the unit.



WARNING! Risk of electric shock

Before turning RF power on, RF ports have to be terminated by nominal 50 Ω load (for example, feeder with antenna). However, if these conditions are not met, the plastic caps that are delivered within the unused RF ports should remain in place. The plastic caps isolate RF port from the environment, and thus provide electric shock security in case RF power is accidentally on.

Antenna Line Devices (ALDs) support

Table 265 FRIJ ALD support

ALD support	Value
AISG	ANT1, ANT3, RET: AISG 2.0
CWA (for non-AISG installations)	No
Voltage	ANT1, ANT3: 14.5 V RET: 14.5 V
Power per port	40 W
Power	60 W

Functional block diagram

Figure 71 FRIJ functional block diagram

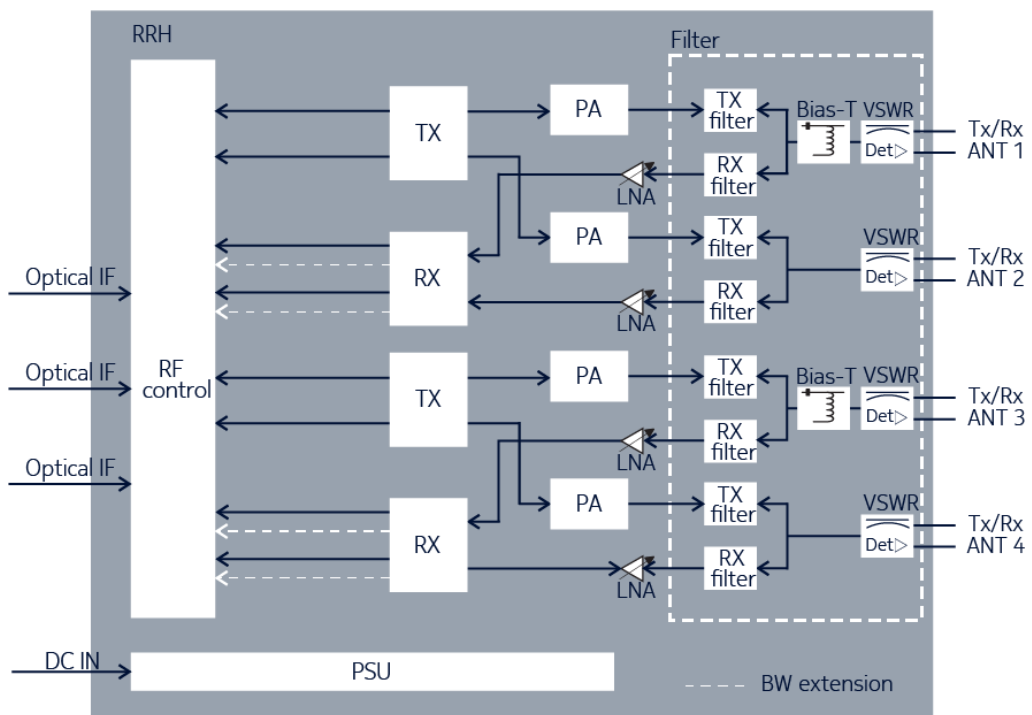

Electrical specifications

Table 266 FRIJ electrical specifications

Property	Value
Nominal supply voltage	-48.0 V DC
Nominal input voltage range	-40.5 V DC to -57.0 V DC
Extended input voltage range	-36.0 V DC to -40.5 V DC -57.0 V DC to -60.0 V DC



Note: The minimum startup voltage is -40.5 V DC. If the input voltage is below/beyond extended limits, the unit might shut down.

Power consumption

Typical power consumption [W] for 48VDC input, at 25°C, representative of typical product performance under the same conditions (HW variant, SW version, configuration, environment, and so on) with +/- 10% margin. Average = (6h low hour load, 10h medium hour load and 8h busy hour load) / 24h

Configurations explained on examples:

- GSM/WCDMA: 2/2/2 = three sectors, two carriers/TRXs per sector
- LTE:
 - o 2/2/2 2Tx = three sectors, two carriers per sector, 2Tx per carrier
 - o 1+1/1+1/1+1 4Tx = three dual-band sectors, one carrier per sector per band, 4Tx per carrier

Some radio units are capable of providing only one sector coverage. Then the power values in the table consider deployment of three radio units.

Table 267 FRIJ power consumption

Mode	Configuration	Output power per carrier [W]	Power consumption ETSI 202706 average load $P_{RRH, static}$	Power consumption ETSI 202706 busy hour load $P_{BH RRH, static}$	Power consumption 100% RF power load $P_{100\% RRH}$
LTE	1/1/1 2Tx	20+20	634	709	868
	1/1/1 2Tx	40+40	746	886	1163
	1/1/1 4Tx	4x20	1005	1155	1473
	1/1/1 4Tx	4x40	1235	1512	2109
WCDMA	1/1/1	20	446	480	558
	2/2/2	20	500	564	702
	3/3/3	20	690	786	1008
	4/4/4	20	748	873	1149
MSR	WCDMA 2/2/2	20 (VAM)	970	1100	1393
	LTE 1/1/1 4Tx 10 MHz	4x10			
	WCDMA 2/2/2 LTE 1/1/1 4Tx 10 MHz	20 (VAM) 4x20	1070	1249	1641

Power reduction

Table 268 FRIJ power reduction in 256 QAM

Single carrier [dB]	Dual carrier [dB]
0.7	0.8



Note: The maximum power reduction (`dlCellPwrRed`) value is 20 dB. High power reduction values may cause radio outages.

Related optional items

- AMPA Pole Mounting Kit (30-120 mm)
- FMNC AirScale 1.0 Medium Fan Kit
- AMLA Flat mount adapter bracket
- FMNH AirScale Ladder Mount Kit
- FPKA/FPKC Flexi Pole Mounting Kit
- AMFQ AirScale RAS2 kit for RRH 600

Installation options

- Wall installation
- Pole installation
- Flat mount without fans on wall or pole
- Vertical book mount without fans
- Horizontal book mount with fans
- Inside the Radio Antenna System (RAS) without fans



NOTICE: Install this RRH in a vertical orientation with connectors on the bottom side, to ensure convection cooling. For horizontal installation fans are required.

Dimensions and weight

Table 269 FRIJ dimensions and weight

Property	Value	Dimensions orientation
Height	Core RRH: 587.2 mm (23.1 in.) With cover, handle, and unit bracket: 600 mm (23.6 in.) With cover, handle, unit bracket, and fan kit: 630.2 mm (24.8 in.)	Dimensions orientation in vertical mount with cover 
Depth	Core RRH: 320 mm (12.6 in.) With cover, handle, and unit bracket: 424 mm (16.7 in.) With cover, handle, unit bracket, and fan kit: 424 mm (16.7 in.)	Dimensions orientation in horizontal mount with cover and fan 
Width	Core RRH: 120 mm (4.7 in.) With cover, handle, and unit bracket: 126 mm (5.0 in.) With cover, handle, unit bracket, and fan kit: 126 mm (5.0 in.)	

Table 269 FRIJ dimensions and weight (Cont.)

Property	Value	Dimensions orientation
	With cover, handle, unit bracket, and fan kit (unit bracket rotated 90 degrees for horizontal mounting) : 143 mm (5.6 in.)	
Weight	Core RRH: 18.5 kg (40.8 lb) With cover, handle, and unit bracket: 20.9 kg (46.1 lb) With cover, handle, unit bracket, and fan kit: 22.1 kg (48.7 lb)	
Volume	Core RRH: 20.4 l With cover, handle, and unit bracket: 30.5 l With cover, handle, unit bracket, and fan kit: 32 l	

Environmental specifications

Table 270 FRIJ environmental specifications

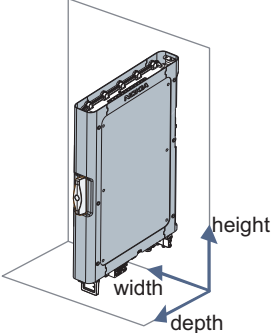
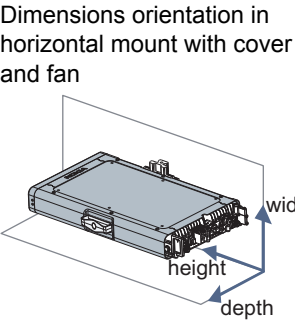
Property	Value
Maximum operational outdoor temperature in the shade, assuming wind speed is 3 m/s (at constant high ambient temperature, maximum output power might be limited)	55°C (131°F)
Maximum operational outdoor temperature in the sun, assuming wind speed is 3 m/s (at constant high ambient temperature, maximum output power might be limited)	50°C (122°F)
Maximum indoor temperature, assuming wind speed is 0 m/s, valid for fanless products (at constant high ambient temperature, maximum output power might be limited)	40°C (104°F)
Minimum operational temperature (including cold start)	-40°C (-40°F)
IP rating	IP65

LTE2516 feature interdependencies

The *LTE2516: Nokia AirScale RRH 4T4R B66 160 W* feature is impacted by the following features:

- *LTE112: Cell Bandwidth - 20 MHz* needs to be enabled to use LTE 20 MHz carriers.
- *LTE113: Cell Bandwidth - 15 MHz* needs to be enabled to use LTE 15 MHz carriers.

- *LTE114: Cell Bandwidth - 10 MHz* needs to be enabled to use LTE 10 MHz carriers.
- *LTE115: Cell Bandwidth - 5 MHz* needs to be enabled to use LTE 5 MHz carriers.
- *With LTE614: Distributed Site*, FRIJ can be used in distributed sites with up to 23 km fiber length to the system module.
- *With LTE977: RF chaining*, FRIJ supports chains of up to four radio units.
- *LTE1103: Load based Power Saving for multi-layer networks* or *LTE1203: Load based Power Saving with Tx path switching off* need to be enabled to use PA shutdown feature.
- *LTE1891: eNode B power saving - Micro DTX* needs to be enabled to use Micro DTX feature.
- *LTE2508: BTS Embedded Power Meter for Energy Efficiency Monitoring* needs to be enabled to use energy metering feature.
- *With LTE3096: Supported RAS Installation options in FL16A Release* RAS installation options are defined.

To enable full output power 1 power licenses per TX pipe are required

- *LTE2149: Supplemental downlink carrier* Supplemental downlink carrier feature is needed to use extra 20MHz in DL spectrum.

5.3 Descriptions of dual band radios

5.3.1 Nokia AirScale Dual RRH 2T4R B1/3 (n1/n3) 240 W (AHEGA)

AHEGA is introduced by LTE3140, SR001575, 5GC002429: Nokia AirScale Dual RRH 2T4R B1/3 (n1/n3) 240 W (AHEGA).

Functional description

Table 271 AHEGA functional specification

Property	Value
Output power	B1/n1: 2x80 W B3/n3: 2x80 W Max power for RRH: 240 W
QAM	256 QAM (DL) 64 QAM (UL)
Number of TXRX	B1/n1: 2T4R B3/n3: 2T4R
Outdoor installation	yes

Table 271 AHEGA functional specification (Cont.)

Property	Value
Supported technologies (standalone and MSR)	B1: WCDMA, FDD-LTE, WCDMA-LTE B3: GSM, FDD-LTE, GSM-LTE n1/n3: 5G
TX frequency range	B1/n1: 2110 – 2170 MHz B3/n3: 1805 – 1880 MHz
RX frequency range	B1/n1: 1920 – 1980 MHz B3/n3: 1710 – 1785MHz
DL filter bandwidth	B1/n1: 60 MHz B3/n3: 75 MHz
UL filter bandwidth	B1/n1: 60 MHz B3/n3: 75 MHz
iBW (instantaneous bandwidth)	B1/n1: 60 MHz B3/n3: 75 MHz
DL oBW	B1/n1 2T2R: 60 MHz B1/n1 2T4R: 40 MHz B3/n3 2T2R: 75 MHz B3/n3 2T4R: 40 MHz
UL oBW	B1/n1: 60 MHz B3/n3: 75 MHz
Number of carriers per pipe	2T4R mode: up to 4 for both bands for all supported RATs 2T2R mode: up to 8 for both bands (4 per band) for all supported RATs
Supported bandwidths	B1: 5, 10, 15, 20 MHz B3: 1.4, 3, 5, 10, 15, 20 MHz n1/n3: 5, 10, 15, 20 MHz
PIM cancellation	Yes

Interfaces

Figure 72 AHEGA interfaces

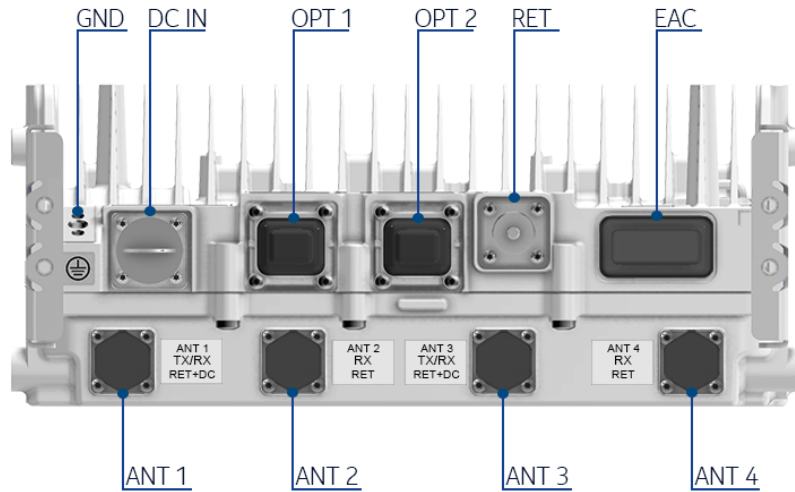

Table 272 AHEGA interfaces

Interface	Label on the HW	Number of interfaces	Connector type	Additional info
Power Connector	DC IN	1	high power circular	APPB, APPC
Antenna connector	ANT	4	4.3-10	AISG on each antenna connector Has features that prevent damage when mating with a 4.1-9.5 connector is attempted
Remote Electrical Tilt	RET	1	8-pin circular	RS-485
External Alarm Connection	EAC	1	MDR26	4 alarm inputs and 1 control output
Optical interface	OPT	2	SFP+	9.8 Gbps, CPRI; Nokia IP seal
Grounding	GND	1	M8 or dual M5 screws	-
Fan	FAN	1	Nokia fan	Located on the heat sink side



WARNING! Risk of electric shock

Before turning RF power on, RF ports have to be terminated by nominal 50 Ω load (for example, feeder with antenna). However, if these conditions are not met, the plastic caps that are delivered within the unused RF ports should remain in place. The plastic caps isolate RF port from the environment, and thus provide electric shock security in case RF power is accidentally on.

Antenna Line Devices (ALDs) support

Table 273 AHEGA ALD support

ALD support	Value
AISG	2.0, 3.0
CWA (for non-AISG installations)	No
Voltage	14.5 V (ANT1 and ANT3 only)
Power per port	30 W, 45 W total

Functional block diagram

Figure 73 AHEGA functional block diagram

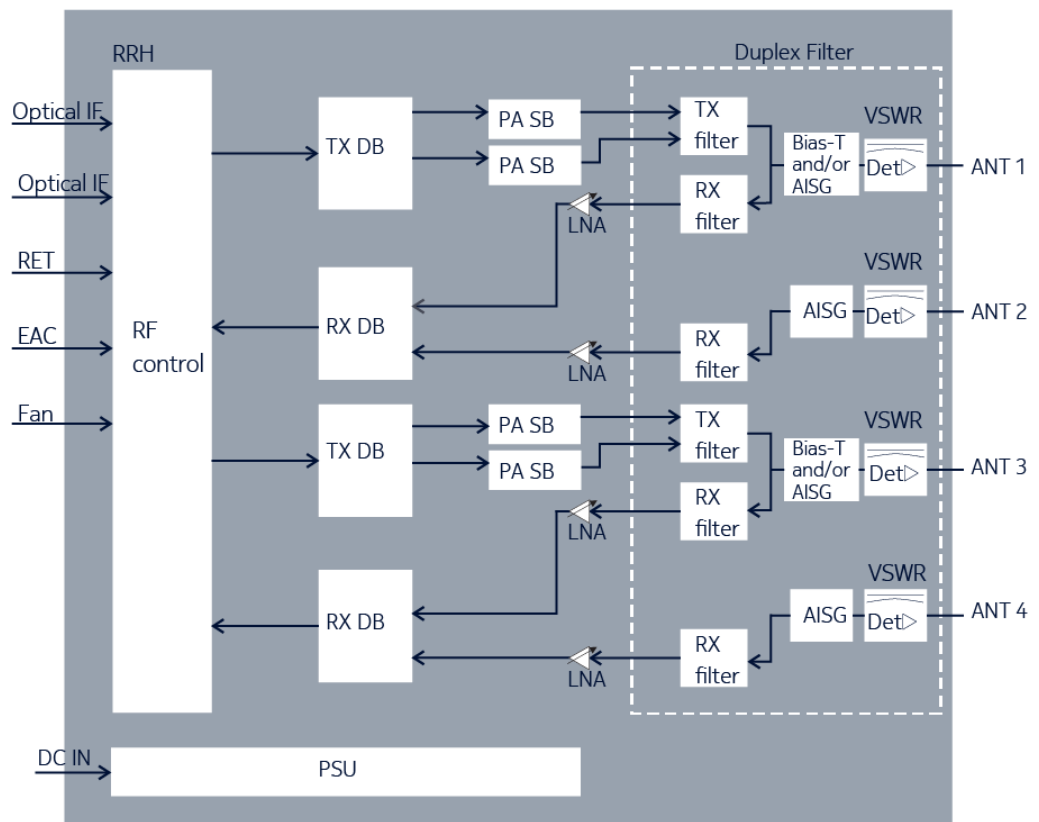

Electrical specifications

Table 274 AHEGA electrical specifications

Property	Value
Nominal supply voltage	-48.0 V DC

Table 274 AHEGA electrical specifications (Cont.)

Property	Value
Nominal input voltage range	-40.5 V DC to -57.0 V DC
Extended input voltage range	-36.0 V DC to -40.5 V DC -57.0 V DC to -60.0 V DC



Note: The minimum start-up voltage is -40.5 V DC. If the input voltage is below/beyond the extended limits, the unit might shut down.

Power consumption

Typical power consumption [W] for 48VDC input, at 25°C, representative of typical product performance under the same conditions (HW variant, SW version, configuration, environment, and so on) with +/- 10% margin. Average = (6h low hour load, 10h medium hour load and 8h busy hour load) / 24h

Configurations explained on examples:

- GSM/WCDMA: 2/2/2 = three sectors, two carriers/TRXs per sector
- LTE:
 - o 2/2/2 2Tx = three sectors, two carriers per sector, 2Tx per carrier
 - o 1+1/1+1/1+1 4Tx = three dual-band sectors, one carrier per sector per band, 4Tx per carrier

Some radio units are capable of providing only one sector coverage. Then the power values in the table consider deployment of three radio units.

Table 275 AHEGA power consumption in LTE mode

Configuration	Output power per carrier [W]	Power consumption ETSI 202706 average P _{RRH, static}	Power consumption ETSI 202706 busy hour load P _{BH RRH, static}	Power consumption 100% RF power load P _{100% RRH}
Single band 1/1/1 2Tx	2x80	1079	1326	1925
Single band 1/1/1 2Tx	2x60	982	1169	1643
Single band 1/1/1 2Tx	2x40	873	992	1294
Single band 1/1/1 2Tx	2x20	772	833	972
Dual band 1+1 / 1+1 / 1+1 2Tx	2x60	1577	1958	2919
Dual band 1+1 / 1+1 / 1+1 2Tx	2x40	1371	1625	2243
Dual band 1+1 / 1+1 / 1+1 2Tx	2x20	1166	1297	1588

Power reduction

Table 276 Recommended AHEGA power reduction per band, in 256 QAM

Single carrier [dB]	Dual carrier [dB]	Triple carrier [dB]	Quad carrier [dB]
0	0.7	0.7	0.9



Note: The maximum power reduction (`dlCellPwrRed`) value is 20 dB. High power reduction values may cause radio outages.

Related optional items

- ASFC AirScale 2 fan unit 600 (474484A)
- AMBE AirScale book mount kit 101-125 (474277A)
- FPKA Flexi Pole Mounting Kit (30-120 mm) (471649A)
- FPKC Flexi Pole Mounting Kit (60-300 mm) (472821A)
- APAF AirScale AC-DC PSU 208-240VAC/1150W (474676A)
- AMPA Pole Mounting Kit (30-120 mm) (473879A)
- AMFD AirScale 2 FPKx Fixing Adapter 600 (474293A)
- ASAA AirScale 2 MDR26-open EAC cable 5 m (474288A)
- APPB AirScale 2 55A DC plug 3.3-10 mm² (474282A)
- APPC AirScale 2 55A DC plug 10-16 mm² (474283A)
- ACPA AirScale 2 Fiber Protection (474297A)
- AMRA AirScale one clip bracket 51-125 (474580A)
- AMRC AirScale one clip rail 600 mm (474583A)

Installation options

- Wall installation
- Pole installation
- Vertical book mount
- Horizontal book mount
- One-clip rail mounting



NOTICE: Install this RRH in a vertical orientation with connectors on the bottom side, to ensure convection cooling. For horizontal installation fans are required.

Dimensions and weight

Table 277 AHEGA dimensions and weight

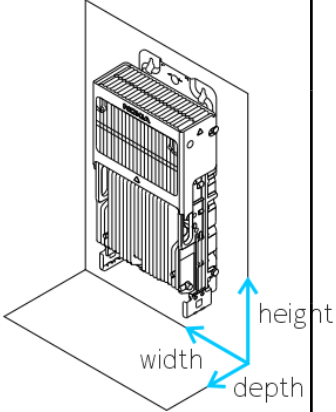
Property	Value	Dimensions orientation
Height	Core RRH: 512 mm (20.2 in.) With upper and lower mounting brackets: 652 mm (25.7 in.)	
Depth	Core RRH: 116.5 mm (4.6 in.) With mounting brackets: 128.5 mm (5.0 in.) With the heat shield: 147 mm (5.8 in.)	
Width	Core RRH: 308 mm (12.1 in.) With side mounting bosses: 321 mm (12.6 in.)	
Weight	24 kg (52.9 lb)	

Environmental specifications

Table 278 AHEGA environmental specifications

Property	Value
Maximum operational outdoor temperature (in the shade) with fan or 10.8 km/h (6.7 mph) wind	55°C (131°F)
Maximum operational outdoor temperature (in the sun) with fan or 10.8 km/h (6.7 mph) wind	50°C (122°F)
Maximum indoor temperature	45°C (113°F)
Minimum operational temperature	-40°C (-40°F)
IP rating	IP65

LTE3140 impact on other features

The *LTE3140: Nokia AirScale Dual RRH 2T4R B1/3 240 W* feature is impacted by the following features:

- *LTE112: Cell Bandwidth - 20 MHz* needs to be enabled to use LTE 20 MHz carriers.
- *LTE113: Cell Bandwidth - 15 MHz* needs to be enabled to use LTE 15 MHz carriers.
- *LTE114: Cell Bandwidth - 10 MHz* needs to be enabled to use LTE 10 MHz carriers.
- *LTE115: Cell Bandwidth - 5 MHz* needs to be enabled to use LTE 5 MHz carriers.
- *LTE116: Cell Bandwidth - 3 MHz* needs to be enabled to use LTE 3 MHz carriers.
- *LTE117: Cell Bandwidth - 1.4 MHz* needs to be enabled to use LTE 1.4MHz carriers.

- With *LTE614: Distributed Site*, AHEGA can be used in distributed sites with up to 23 km fiber length to the system module.
- *LTE1103: Load based Power Saving for multi-layer networks* needs to be enabled to use Load based Power Saving for multi-layer networks.
- *LTE1203: Load based Power Saving with Tx path switching off* needs to be enabled to use Load based Power Saving with Tx path switching off.
- *LTE2508: BTS Embedded Power Meter for Energy Efficiency Monitoring* needs to be enabled to use BTS Embedded Power Meter for Energy Efficiency Monitoring.
- With *LTE2541: Nokia CPRI RRH/RFM chaining*, AHEGA supports Nokia CPRI chain of up to four radio units.
- *LTE3036: Micro DTX extension* needs to be enabled to use Micro DTX extension.
- With *LTE3500: Supported RAS Installation options in FL17A Release* RAS installation options are defined.

5.3.2 Nokia AirScale Dual RRH 2T2R B29/70 200 W (AHLJA)

AHLJA is introduced by *LTE4228: Nokia AirScale RRH Dual 2T2R B29/70 200 W (AHLJA)*.

Functional description

Table 279 AHLJA functional specification

Property	Value
Output power	B70 (DL) / PCS H (UL): 2x60 W B29 (DL): 2x40 W
QAM	256 QAM (DL) 64 QAM (UL)
Number of TXRX	2T2R
Outdoor installation	Yes
Supported technologies (standalone and MSR)	FDD-LTE, 5G-ready i Note: AHLJA operates in LTE only in B70 in supplementary downlink (SDL) mode.
IoT support	NB-IoT standalone (SA) i Note: AHLJA supports two DL carriers in B70, one DL carrier in B29 and three UL carriers in PCS-H (non-3GPP band). Only a special non-3GPP UE can utilize it.
TX frequency range	B70 NB-IoT: 1995–2020 MHz B70 LTE: 2000–2020 MHz

Table 279 AHLJA functional specification (Cont.)

Property	Value
	B29: 717–728 MHz
RX frequency range	1915–1920 MHz
DL filter bandwidth	Ant 1, Ant 2 (B70 NB-IoT): 25 MHz Ant 1, Ant 2 (B70 LTE): 20 MHz Ant 3, Ant 4 (B29): 11 MHz
UL filter bandwidth	Ant 1, Ant 2 (PCS H): 5 MHz
DL iBW (instantaneous bandwidth)	B70 NB-IoT: 25 MHz B70 LTE: 20 MHz B29: 11 MHz
UL iBW (instantaneous bandwidth)	5 MHz
DL oBW	Ant 1, Ant 2 (NB-IoT): 25 MHz Ant 1, Ant 2 (LTE): 20 MHz Ant 3, Ant 4: 11 MHz
UL oBW	Ant 1, Ant 2: 5 MHz
Number of carriers per pipe	Up to 3
Supported bandwidths	LTE in B70: 5, 10, 15, 20 MHz NB-IoT in B29: 5, 10 MHz
PIM cancellation	Yes

Interfaces

Figure 74 AHLJA interfaces

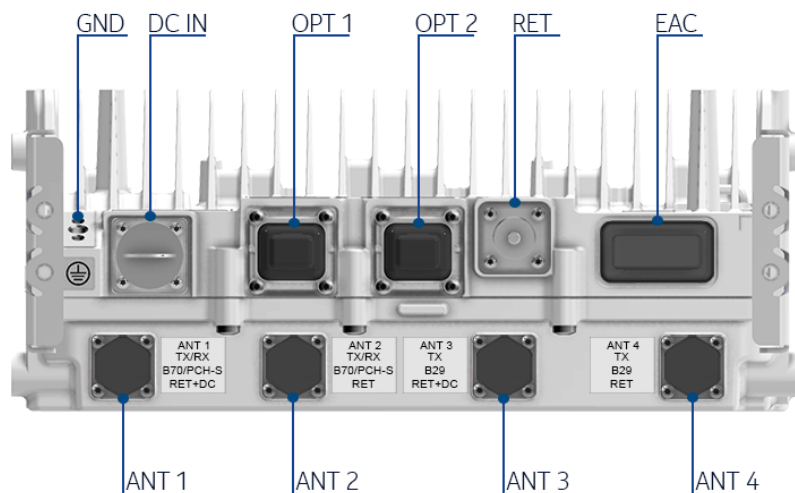

Table 280 AHLJA interfaces

Interface	Label on the HW	Number of interfaces	Connector type	Additional info
Power Connector	DC IN	1	High power circular	APPB, APPC
Antenna connector	ANT	4	4.3-10	AISG on all ports, BiasT support on ANT1 & ANT3
Remote Electrical Tilt	RET	1	8-pin circular	RS-485
External Alarm Connection	EAC/LMP	1	MDR26	4 alarm inputs and 1 control output
Optical interface	OPT	2	SFP+ (R2CT)	9.8 Gbps, CPRI; Nokia IP seal
Grounding		1	M8 or dual M5 screws	-
Fan	FAN	1	Nokia fan	Located on the heat sink side



WARNING! Risk of electric shock

Before turning RF power on, RF ports have to be terminated by nominal 50 Ω load (for example, feeder with antenna). However, if these conditions are not met, the plastic caps that are delivered within the unused RF ports should remain in place. The plastic caps isolate RF port from the environment, and thus provide electric shock security in case RF power is accidentally on.

Antenna Line Devices (ALDs) support

Table 281 AHLJA ALD support

ALD support	Value
AISG	3.0
Voltage	14.5 V (ANT1 and ANT3 only)
Power per port	40 W, 60 W

Functional block diagram

Figure 75 AHLJA functional block diagram

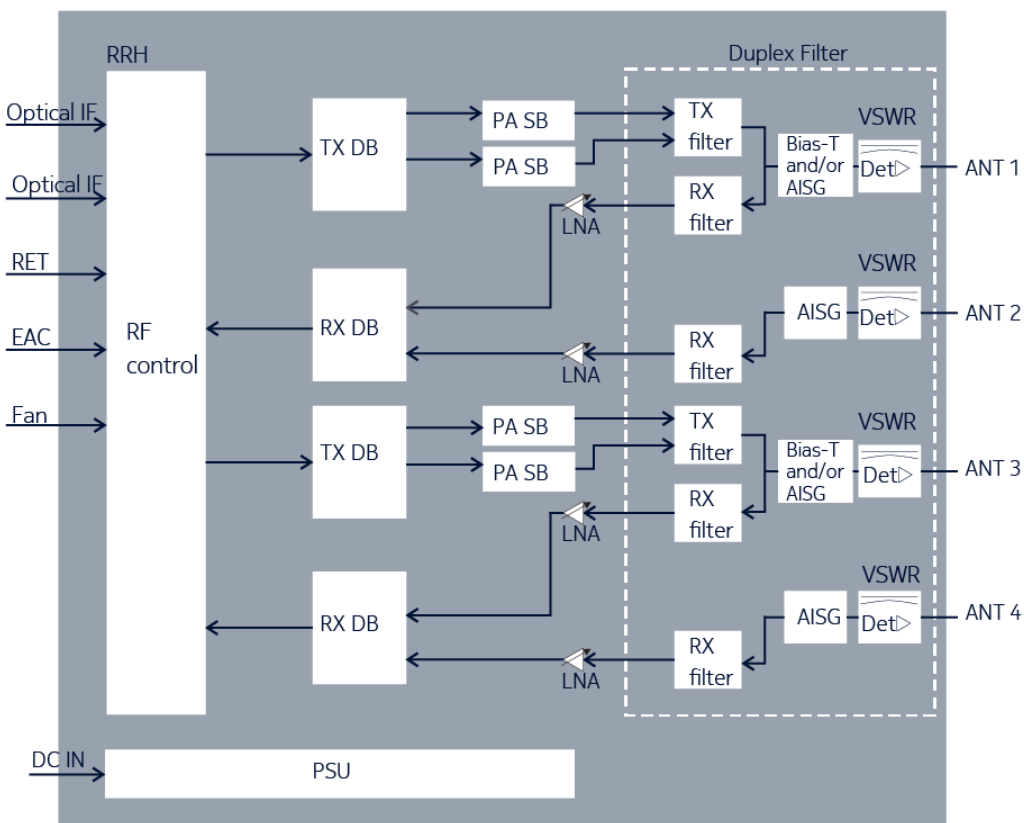

Electrical specifications

Table 282 AHLJA electrical specifications

Property	Value
Nominal supply voltage	-48.0 V DC
Nominal input voltage range	-40.5 V DC to -57.0 V DC
Extended input voltage range	-36.0 V DC to -40.5 V DC -57.0 V DC to -60.0 V DC



Note: The minimum start-up voltage is -40.5 V DC. If the input voltage is below/beyond the extended limits, the unit might shut down.

Power consumption



Note: AHLJA power consumption will be provided in future releases.

Power Reduction

Table 283 Recommended AHLJA power reduction per band, in 256 QAM

Single carrier [dB]	Dual carrier [dB]	Triple carrier [dB]	Quad carrier [dB]
0	0.7	0.7	0.9



Note: The maximum power reduction (`dlCellPwrRed`) value is 20 dB. High power reduction values may cause radio outages.

Related optional items

- ASFC AirScale 2 fan unit 600 (474484A)
- AMBF AirScale book mount kit 126-150 (474278A)
- FPKA Flexi Pole Mounting Kit (30-120 mm) (471649A)
- FPKC Flexi Pole Mounting Kit (60-300 mm) (472821A)
- AMPA Pole Mounting Kit (30-120 mm) (473879A)
- APAF AirScale AC-DC PSU 208-240VAC/1150W (474676A)
- AMFD AirScale 2 FPKx Fixing Adapter 600 (474293A)
- ASAA AirScale 2 MDR26-open EAC cable 5 m (474288A)
- APPB AirScale 2 55A DC plug 3.3-10 mm² (474282A)
- APPC AirScale 2 55A DC plug 10-16 mm² (474283A)
- ACPA AirScale 2 Fiber Protection (474297A)
- AMRB AirScale one clip bracket 126-200 (474581A)
- AMRC AirScale one clip rail 600 mm (474583A)

Installation options

- Wall installation
- Pole installation
- Vertical book mount
- Horizontal book mount (fan is required)
- One-clip rail installation



NOTICE: Install this RRH in a vertical orientation with connectors on the bottom side, to ensure convection cooling. For horizontal installation fans are required.

Dimensions and weight

Table 284 AHLJA dimensions and weight

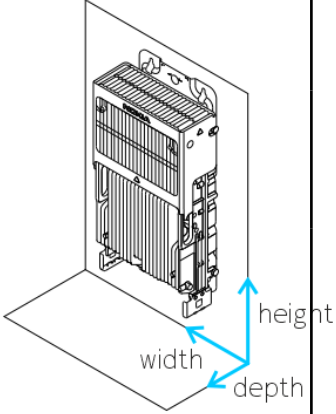
Property	Value	Dimensions orientation
Height	Core RRH: 512 mm (20.2 in.) With upper and lower mounting brackets: 630 mm (24.8 in.)	
Width	Core RRH: 308 mm (12.1 in.) With side mounting bosses: 321 mm (12.6 in.)	
Depth	Core RRH: 130 mm (5.1 in.) With mounting brackets: 142 mm (5.6 in.) With the heat shield: 147 mm (5.8 in.)	
Weight	24.0 kg (52.9 lb)	

Environmental specifications

Table 285 AHLJA environmental specifications

Property	Value
Maximum operational outdoor temperature (in the shade) with fan or 10.8 km/h (6.7 mph) wind	55°C (131°F)
Maximum operational outdoor temperature (in the sun) with fan or 10.8 km/h (6.7 mph) wind	50°C (122°F)
Maximum indoor temperature	45°C (113°F)
Minimum operational temperature	-40°C (-40°F)
IP rating	IP65

LTE4228 feature interdependencies

The *LTE4228: Nokia AirScale RRH Dual 2T2R B29/70 200 W (AHLJA)* feature is impacted by the following features:

- *LTE 114: Cell Bandwidth - 10 MHz* enables 10 MHz carriers.
- *LTE 115: Cell Bandwidth - 5 MHz* enables 5 MHz carriers.
- With *LTE 614: Distributed Site* AHLJA can be used in distributed sites with up to 23 km fiber length to the system module.
- *LTE1103: Load based Power Saving for multi-layer networks* enables to save energy during low-load periods in the network where there is more than one provisioned frequency.
- *LTE1203: Load based Power Saving with Tx path switching off* enables monitoring of the system to increase or reduce capacity.
- *LTE2428: Nokia CPRI in FDD-LTE* provides support for CPRI interface.
- *LTE2508: BTS Embedded Power Meter for Energy Efficiency Monitoring* provides energy-monitoring software support for radio frequency (RF) modules .

- *LTE2541: Nokia CPRI RRH/RFM chaining* provides support for chaining.
- *LTE3036: Micro DTX extension* provides energy saving of the eNB.
- *LTE3571: NB-IoT Co-existence with UL CoMP and eICIC* provides additional use cases for NB-IoT and less interaction restrictions with other features for inband and guardband modes.
- *LTE4162: Three SA NB-IoT carriers with special duplexing gap* allows special NB-IoT standalone configurations.
- *LTE5373: LTE support for AHLJA B70 SDL* allows to use AHLJA in supplementary downlink mode in LTE band B70.

5.3.3 Nokia AirScale Dual RRH 4T4R B1/3 (n1/n3) 320 W (AHEGB)

AHEGB (474090A) is introduced by LTE3681, SR001668, 5GC001688: Nokia AirScale Dual RRH 4T4R B1/3 (n1/n3) 320 W (AHEGB).

Functional description

Table 286 AHEGB functional specification

Property	Value
Output power	2x4x40 W
QAM	256 QAM (DL) 64 QAM (UL)
Number of TXRX	4T4R
Outdoor installation	Yes
Supported technologies (standalone and MSR)	B1/n1: WCDMA, FDD-LTE, WCDMA-LTE, 5G B3/n3: GSM, FDD-LTE, GSM-LTE, 5G
TX frequency range	B1/n1: 2110 – 2170 MHz B3/n3: 1805 – 1880 MHz
RX frequency range	B1/n1: 1920 – 1980 MHz B3/n3: 1710 – 1785 MHz
DL filter bandwidth	B1/n1: 60 MHz B3/n3: 75 MHz
UL filter bandwidth	B1/n1: 60 MHz B3/n3: 75 MHz
iBW (instantaneous bandwidth)	B1/n1: 60 MHz B3/n3: 75 MHz
oBW (occupied bandwidth)	B1/n1: 60 MHz B3/n3: 75 MHz

Table 286 AHEGB functional specification (Cont.)

Property	Value
Number of carriers per pipe	Up to 8 carriers in total for all supported RATs
Supported bandwidths	LTE B1: 5, 10, 15, 20 MHz LTE B3: 1.4, 3, 5, 10, 15, 20 MHz 5G n1/n3: 5, 10, 15, 20 MHz
PIM cancellation	Yes

Interfaces

Figure 76 AHEGB interfaces

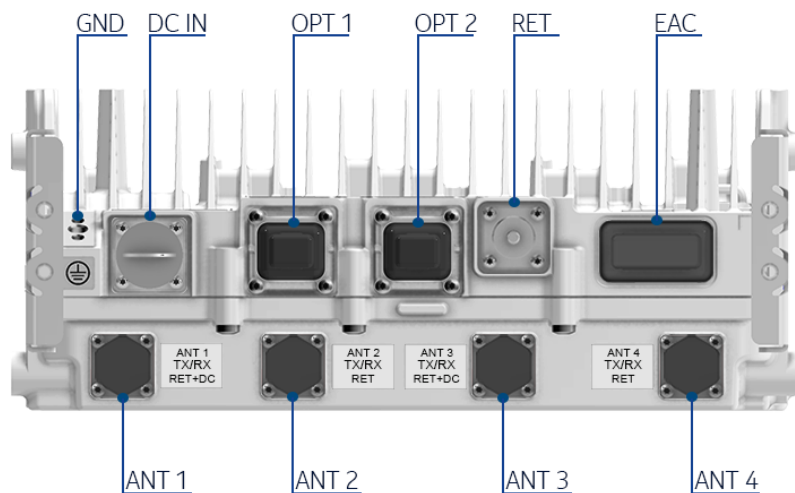

Table 287 AHEGB interfaces

Interface	Label on the HW	Number of interfaces	Connector type	Additional info
Power Connector	DC IN	1	High power circular	APPB, APPC
Antenna connector	ANT	4	4.3-10	AISG on all ports, BiasT support on ANT1 & ANT3 Has features that prevent damage if mating with a 4.1-9.5 connector is attempted
Remote Electrical Tilt	RET	1	8-pin circular	RS-485

Table 287 AHEGB interfaces (Cont.)

Interface	Label on the HW	Number of interfaces	Connector type	Additional info
External Alarm Connection	EAC	4	MDR26	4 alarm inputs and 1 control output
Optical interface	OPT	2	SFP+	9.8 Gbps, CPRI; Nokia IP seal
Grounding	GND	1	M8 or dual M5 screws	-
Fan	FAN	1	Nokia fan	Located on the heat sink side

**WARNING! Risk of electric shock**

Before turning RF power on, RF ports have to be terminated by nominal 50 Ω load (for example, feeder with antenna). However, if these conditions are not met, the plastic caps that are delivered within the unused RF ports should remain in place. The plastic caps isolate RF port from the environment, and thus provide electric shock security in case RF power is accidentally on.

Antenna Line Devices (ALDs) support

Table 288 AHEGB ALD support

ALD support	Value
AISG	2.0, 3.0
CWA (for non-AISG installations)	No
Voltage	14.5 V (ANT1 and ANT3 only)
Power per port	30 W, 45 W total

Functional block diagram

Figure 77 AHEGB functional block diagram

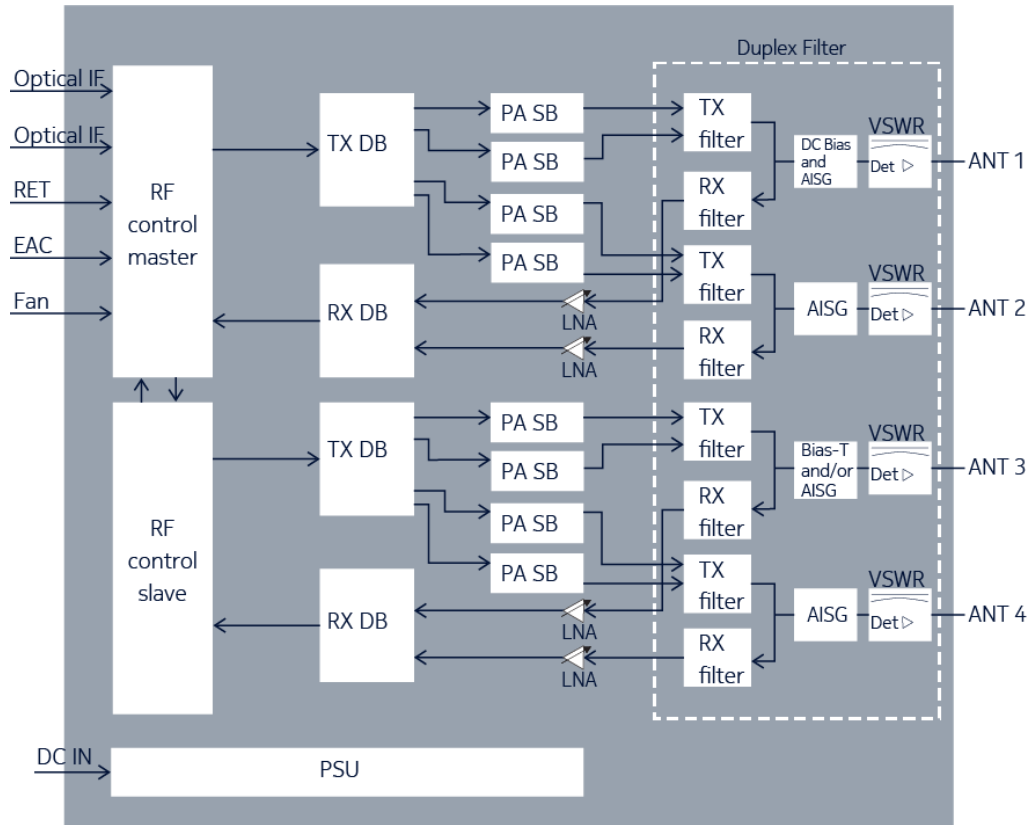

Electrical specifications

Table 289 AHEGB electrical specifications

Property	Value
Nominal supply voltage	-48.0 V DC
Nominal input voltage range	-40.5 V DC to -57.0 V DC
Extended input voltage range	-36.0 V DC to -40.5 V DC -57.0 V DC to -60.0 V DC



Note: The minimum start-up voltage is -40.5 V DC. If the input voltage is below/beyond the extended limits, the unit might shut down.

Power consumption

Typical power consumption [W] for 48VDC input, at 25°C, representative of typical product performance under the same conditions (HW variant, SW version, configuration, environment, and so on) with +/- 10% margin. Average = (6h low hour load, 10h medium hour load and 8h busy hour load) / 24h

Configurations explained on examples:

- GSM/WCDMA: 2/2/2 = three sectors, two carriers/TRXs per sector
- LTE:

- o 2/2/2 2Tx = three sectors, two carriers per sector, 2Tx per carrier
- o 1+1/1+1/1+1 4Tx = three dual-band sectors, one carrier per sector per band, 4Tx per carrier

Some radio units are capable of providing only one sector coverage. Then the power values in the table consider deployment of three radio units.

Table 290 AHEGB power consumption in LTE mode

Configuration	Output power per carrier [W]	Power consumption ETSI 202706 average P_{RRH} , static	Power consumption ETSI 202706 busy hour load $P_{BH\ RRH}$, static	Power consumption 100% RF power load $P_{100\% \ RRH}$
Single band 1/1/1 4Tx	4x40	1397	1657	2264
Single band 1/1/1 4Tx	4x20	1050	1163	1451
Single band 1/1/1 2Tx	2x40	977	1103	1403
Single band 1/1/1 2Tx	2x20	811	867	1010
Dual band 1+1 / 1+1 /1+1 4Tx	4x40	2177	2676	3822
Dual band 1+1 / 1+1 / 1+1 4Tx	4x20	1532	1768	2321
Dual band 1+1 / 1+1 / 1+1 2Tx	2x40	1365	1613	2201
Dual band 1+1 / 1+1 / 1+1 2Tx	2x20	1049	1168	1448

Power reduction

Table 291 Recommended AHEGB power reduction per band, in 256 QAM

Single carrier [dB]	Dual carrier [dB]	Triple carrier [dB]	Quad carrier [dB]
0	0.7	0.7	0.9



Note: The maximum power reduction (`dlCellPwrRed`) value is 20 dB. High power reduction values may cause radio outages.

Related optional items

- ASFC AirScale 2 fan unit 600 (474484A)
- AMBF AirScale book mount kit 126-150 (474278A)
- FPKA Flexi Pole Mounting Kit (30-120 mm) (471649A)
- FPKC Flexi Pole Mounting Kit (60-300 mm) (472821A)
- AMPA Pole Mounting Kit (30-120 mm) (473879A)
- AMFD AirScale 2 FPKx Fixing Adapter 600 (474293A)
- ASAA AirScale 2 MDR26-open EAC cable 5 m (474288A)

- APPB AirScale 2 55A DC plug 3.3-10 mm² (474282A)
- APPC AirScale 2 55A DC plug 10-16 mm² (474283A)
- ACPA AirScale 2 Fiber Protection (474297A)
- AMRB AirScale one clip bracket 126-200 (474581A)
- AMRC AirScale one clip rail 600 mm (474583A)

Installation options

- Wall installation
- Pole installation
- Vertical book mount
- Horizontal book mount (fan is required)
- One-clip rail installation



NOTICE: Install this RRH in a vertical orientation with connectors on the bottom side, to ensure convection cooling. For horizontal installation fans are required.

Dimensions and weight

Table 292 AHEGB dimensions and weight

Property	Value	Dimensions orientation
Height	Core RRH: 560 mm (22.0 in.) With upper and lower mounting brackets: 675 mm (26.6 in.)	
Width	Core RRH: 308 mm (12.1 in.) With mounting brackets: 327 mm (12.9 in.)	
Depth	Core RRH: 149 mm (5.9 in.) With mounting brackets: 160 mm (6.3 in.)	
Weight	30 kg (66.1 lb)	

Environmental specifications

Table 293 AHEGB environmental specifications

Property	Value
Maximum operational outdoor temperature (in the shade) with fan or 10.8 km/h (6.7 mph) wind	55°C (131°F)
Maximum operational outdoor temperature (in the sun) with fan or 10.8 km/h (6.7 mph) wind	50°C (131°F)
Maximum indoor temperature	45°C (113°F)
Minimum operational temperature	-40°C (-40°F)
IP rating	IP65

AHEGB interdependencies features

The *AirScale Dual RRH 4T4R B1/3 320W AHEGB* feature is impacted by the following features:

- *LTE 112: Cell Bandwidth - 20 MHz* enables 20 MHz carriers.
- *LTE 113: Cell Bandwidth - 15 MHz* enables 15 MHz carriers.
- *LTE 114: Cell Bandwidth - 10 MHz* enables 10 MHz carriers.
- *LTE 115: Cell Bandwidth - 5 MHz* enables 5 MHz carriers.
- *LTE 116: Cell Bandwidth - 3 MHz* enables 3 MHz carriers.
- *LTE 117: Cell Bandwidth - 1.4 MHz* enables 1.4 MHz carriers.
- With *LTE 614: Distributed Site*, AHEGB can be used in distributed sites with up to 23 km fiber length to the system module.
- *LTE1103: Load based Power Saving for multi-layer networks* enables Load based Power Saving for multi-layer networks.
- *LTE1203: Load based Power Saving with Tx path switching* enables Load based Power Saving with Tx path switching off.
- *LTE2428: Nokia CPRI in FDD-LTE* provide support for CPRI interface.
- *LTE2508: BTS Embedded Power Meter for Energy Efficiency Monitoring* enables BTS Embedded Power Meter for Energy Efficiency Monitoring.
- *LTE2863: PIM Cancellation for AirScale 2.0 Radios* enables PIM cancellation feature (licensed feature).
- *LTE3036: Micro DTX extension* enables Micro DTX extension.

5.3.4 Nokia AirScale Dual RRH 4T4R B1/3 (n1/n3) 400 W (AHEGC)

AHEGC is introduced by LTE4970, SR002211, 5GC002335: Nokia AirScale Dual RRH 4T4R B1/3 (n1/n3) 400 W (AHEGC).

Functional description

Table 294 AHEGC functional specification

Property	Value
Output power	B1/n1: 4x60 W / B3/n3: 4x40 W B1/n1: 4x40 W / B3/n3: 4x60 W
QAM	256 QAM (DL) 64 QAM (UL)
Number of TXRX	4T4R
Outdoor installation	Yes
Supported technologies (standalone and MSR)	B1: WCDMA, FDD-LTE, WCDMA-LTE B3: GSM, FDD-LTE, GSM-LTE n1/n3: 5G
IoT support	NB-IoT in band, guard band (GB), standalone (SA)

Table 294 AHEGC functional specification (Cont.)

Property	Value
TX frequency range	B1/n1: 2110 - 2170 MHz B3/n3: 1805 - 1880 MHz
RX frequency range	B1/n1: 1920 - 1980 MHz B3/n3: 1710 - 1785 MHz
DL filter bandwidth	B1/n1: 60 MHz B3/n3: 75 MHz
UL filter bandwidth	B1/n1: 60 MHz B3/n3: 75 MHz
iBW (instantaneous bandwidth)	B1/n1: 60 MHz B3/n3: 75 MHz
oBW (occupied bandwidth)	B1/n1: 60 MHz B3/n3: 75 MHz
Number of carriers per pipe	Up to 8 carriers in total for all supported RATs
Supported bandwidths	B1: 5, 10, 15, 20 MHz B3: 1.4, 3, 5, 10, 15, 20 MHz n1/n3: 5, 10, 15, 20 MHz
PIM cancellation	Yes

Interfaces

Figure 78 AHEGC interfaces

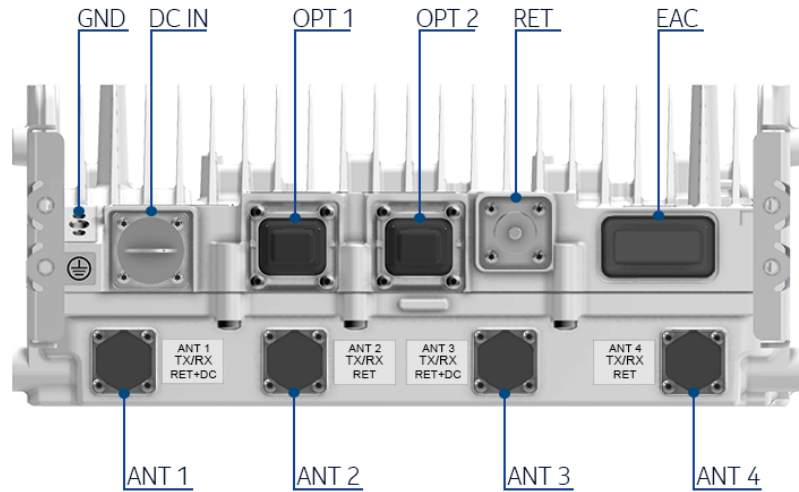



Table 295 AHEGC interfaces

Interface	Label on the HW	Number of interfaces	Connector type	Additional info
Power Connector	DC IN	1	High power circular	APPB, APPC
Antenna connector	ANT	4	4.3-10	AISG on all ports, BiasT support on ANT1 & ANT3; has features that prevent damage if mating with a 4.1-9.5 connector is attempted
Remote Electrical Tilt	RET	1	8-pin circular	RS485
External Alarm Connection	EAC	4	MDR26	4 inputs and 1 control output
Optical interface	OPT	2	SFP+	9.8 Gbps, CPRI; Nokia IP seal
Grounding		1	M8 or dual M5 screws	-
Fan	FAN	1	Nokia fan	Located on the heat sink side



WARNING! Risk of electric shock

Before turning RF power on, RF ports have to be terminated by nominal 50 Ω load (for example, feeder with antenna). However, if these conditions are not met, the plastic caps that are delivered within the unused RF ports should remain in place. The plastic caps isolate RF port from the environment, and thus provide electric shock security in case RF power is accidentally on.

Antenna Line Devices (ALDs) support

Table 296 AHEGC ALD support

Property	Value
AISG	2.0, 3.0
CWA (for non-AISG installations)	No
Voltage	14.5 V (ANT1 and ANT3 only)
Power per port	30 W, 45 W total

Functional block diagram

Figure 79 AHEGC functional block diagram

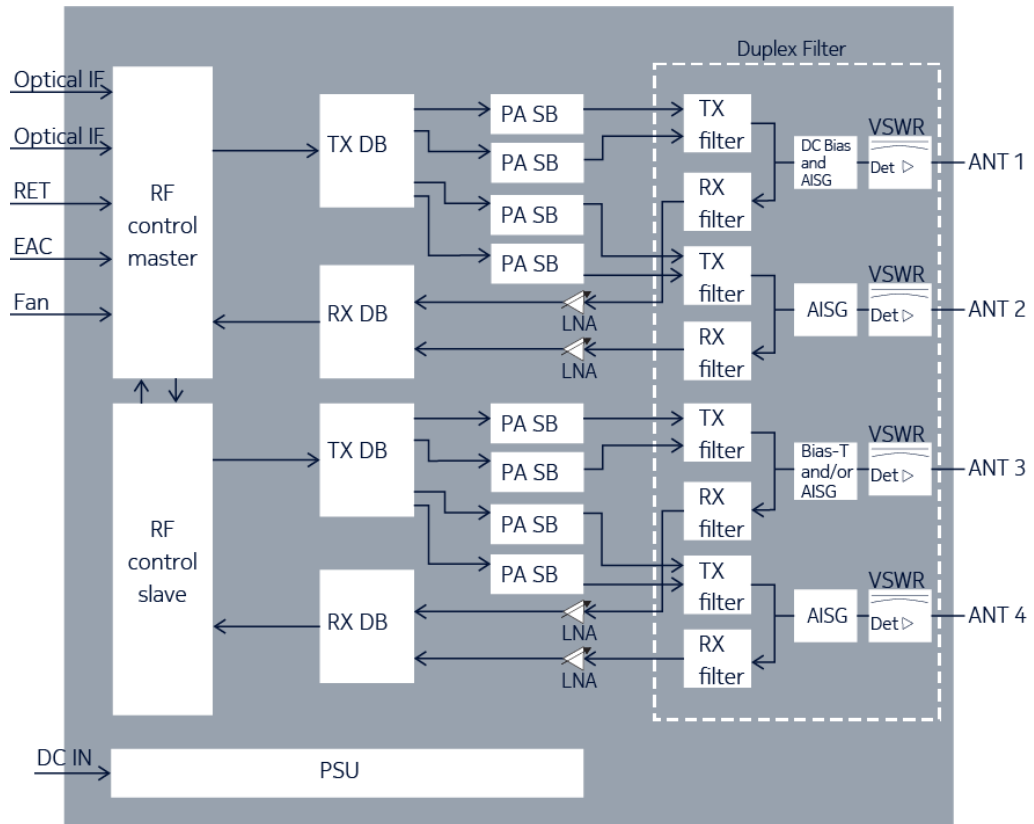

Electrical specifications

Table 297 AHEGC electrical specifications

Property	Value
Nominal supply voltage	-48.0 V DC

Table 297 AHEGC electrical specifications (Cont.)

Property	Value
Nominal input voltage range	–40.5 V DC to –57.0 V DC
Extended input voltage range	–36.0 V DC to –40.5 V DC –57.0 V DC to –60.0 V DC



Note: The minimum start-up voltage is –40.5 V DC. If the input voltage is below/beyond the extended limits, the unit might shut down.

Power consumption

Typical power consumption [W] for 48VDC input, at 25°C, representative of typical product performance under the same conditions (HW variant, SW version, configuration, environment, and so on) with +/- 10% margin. Average = (6h low hour load, 10h medium hour load and 8h busy hour load) / 24h

Configurations explained on examples:

- GSM/WCDMA: 2/2/2 = three sectors, two carriers/TRXs per sector
- LTE:
 - o 2/2/2 2Tx = three sectors, two carriers per sector, 2Tx per carrier
 - o 1+1/1+1/1+1 4Tx = three dual-band sectors, one carrier per sector per band, 4Tx per carrier

Some radio units are capable of providing only one sector coverage. Then the power values in the table consider deployment of three radio units.

Table 298 AHEGC power consumption in LTE mode

Configuration	Output power per carrier [W]	Power consumption ETSI 202706 average P_{RRH} , static	Power consumption ETSI 202706 busy hour load $P_{BH\ RRH}$, static	Power consumption 100% RF power load $P_{100\% \ RRH}$
Single band 1/1/1 4Tx	4x60	1642	2028	2910
Single band 1/1/1 4Tx	4x40	1385	1635	2167
Single band 1/1/1 4Tx	4x20	1135	1272	1531
Single band 1/1/1 2Tx	2x60	1112	1299	1727
Single band 1/1/1 2Tx	2x40	985	1108	1371
Single band 1/1/1 2Tx	2x20	866	935	1067
Dual band 1+1 / 1+1 / 1+1 4Tx	4x50	2462	3114	4633

Table 298 AHEGC power consumption in LTE mode (Cont.)

Configuration	Output power per carrier [W]	Power consumption ETSI 202706 average P_{RRH} , static	Power consumption ETSI 202706 busy hour load $P_{BH,RRH}$, static	Power consumption 100% RF power load $P_{100\%RRH}$
Dual band 1+1 / 1+1 / 1+1 4Tx	4x40	2172	2690	3815
Dual band 1+1 / 1+1 / 1+1 4Tx	4x20	1664	1946	2489
Dual band 1+1 / 1+1 / 1+1 2Tx	2x50	1505	1821	2563
Dual band 1+1 / 1+1 / 1+1 2Tx	2x40	1370	1624	2176
Dual band 1+1 / 1+1 / 1+1 2Tx	2x20	1123	1262	1529

Power reduction

Table 299 Recommended AHEGC power reduction per band, in 256 QAM

Single carrier [dB]	Dual carrier [dB]	Triple carrier [dB]	Quad carrier [dB]
0	0.7	0.7	0.9



Note: The maximum power reduction ($d1CellPwrRed$) value is 20 dB. High power reduction values may cause radio outages.

Related optional items

- AMBF AirScale book mount kit 126-150 (474278A)
- FPKA Flexi Pole Mounting Kit (30-120 mm) (471649A)
- FPKC Flexi Pole Mounting Kit (60-300 mm) (472821A)
- AMPA Pole Mounting Kit (30-120 mm) (473879A)
- AMFD AirScale 2 FPKx Fixing Adapter 600 (474293A)
- ASAA AirScale 2 MDR26-open EAC cable 5 m (474288A)
- APPB AirScale 2 55A DC plug 3.3-10 mm² (474282A)
- APPC AirScale 2 55A DC plug 10-16 mm² (474283A)
- ACPA AirScale 2 Fiber Protection (474297A)
- AMRB AirScale one clip bracket 126-200 (474581A)
- AMRC AirScale one clip rail 600 mm (474583A)

Installation options

- Wall installation
- Pole installation
- Vertical book mount
- Horizontal book mount
- One-clip rail mounting

Dimensions and weight

Table 300 AHEGC dimensions and weight

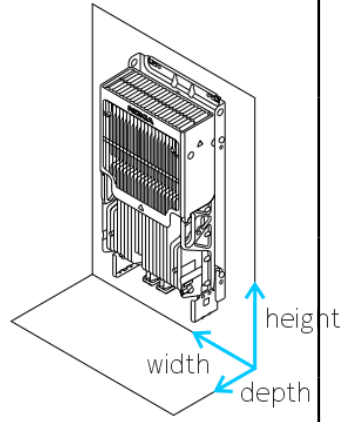
Property	Value	Dimensions orientation
Height	Core RRH: 560 mm (22.05 in.) With fan unit: 701 mm (27.59 in.)	
Width	Core RRH: 308 mm (12.13 in.) With mounting bracket: 327 mm (12.87 in.)	
Depth	Core RRH: 149 mm (5.86 in.) With mounting bracket: 162 mm (6.37 in.)	
Weight	Core RRH: 34 kg (75.0 lb)	
Volume	Core RRH: 34 l	

Environmental specifications

Table 301 AHEGC environmental specifications

Property	Value
Maximum operational outdoor temperature (in the shade)	55°C (131°F)
Maximum operational outdoor temperature (in the sun)	55°C (131°F)
Maximum indoor temperature	55°C (131°F)
Minimum operational temperature	-40°C (-40°F)
IP rating	IP65

Feature interdependencies

The *LTE4970: Nokia AirScale Dual RRH 4T4R B1/3 400W AHEGC* feature is impacted by the following features:

- *LTE112: Cell Bandwidth - 20 MHz* needs to be enabled to use LTE 20 MHz carriers.
- *LTE113: Cell Bandwidth - 15 MHz* needs to be enabled to use LTE 15 MHz carriers.
- *LTE114: Cell Bandwidth - 10 MHz* needs to be enabled to use LTE 10 MHz carriers.
- *LTE115: Cell Bandwidth - 5 MHz* needs to be enabled to use LTE 5 MHz carriers.
- *LTE116: Cell Bandwidth - 3 MHz* needs to be enabled to use LTE 3MHz carriers.
- *LTE117: Cell Bandwidth - 1.4 MHz* needs to be enabled to use LTE 1.4MHz carriers.

- With *LTE614: Distributed Site*, AHEGC can be used in distributed sites with up to 23 km fiber length to the system module.
- *LTE1103: Load based Power Saving for multi-layer networks* works when enabled in the settings.
- *LTE1203: Load based Power Saving with Tx path switching off* works when enabled in the settings.
- *LTE2428: Nokia CPRI in FDD-LTE* provides support for CPRI interface.
- *LTE2508: BTS Embedded Power Meter for Energy Efficiency Monitoring* works when enabled in the settings.
- With *LTE2541: Nokia CPRI RRH/RFM chaining*, AHEGC supports Nokia CPRI chain of up to four radio units.
- *LTE2863: PIM Cancellation for AirScale 2.0 Radios* needs to be enabled to activate PIM cancellation feature (licenced feature).
- *LTE3036: Micro DTX extension* works when enabled in the settings.

5.3.5 Nokia AirScale Dual RRH 4T4R B2/66a (n2/n66a) 320 W (AHFIC)

AHFIC is introduced by *LTE3845, SR002039, 5GC000934: Nokia AirScale Dual RRH 4T4R B2/66a (n2/n66a) 320 W (AHFIC)*.

Functional description

Table 302 AHFIC functional specification

Property	Value
Output power	B2/n2: 4x40 W B66a/n66a: 4x60 W Max power for RRH: 320 W
QAM	256 QAM (DL) 64 QAM (UL)
Number of TXRX	B2/n2: 4T4R B66a/n66a: 4T4R
Outdoor installation	Yes
Supported technologies (standalone and MSR)	B2/n2: GSM, WCDMA, FDD-LTE, GSM-LTE, GSM-WCDMA, WCDMA-LTE, GSM-WCDMA-LTE, 5G B66a/n66a: FDD-LTE, 5G
TX frequency range	B2/n2: 1930 - 1990 MHz B66a/n66a: 2110 - 2180 MHz

Table 302 AHFIC functional specification (Cont.)

Property	Value
RX frequency range	B2/n2: 1850 - 1910 MHz B66a/n66a: 1710 - 1780 MHz
DL filter bandwidth	B2/n2: 60 MHz B66a/n66a: 70 MHz
UL filter bandwidth	B2/n2: 60 MHz B66a/n66a: 70 MHz
iBW (instantaneous bandwidth)	B2/n2: 60 MHz B66a/n66a: 70 MHz
oBW (occupied bandwidth)	B2/n2: 60 MHz B66a/n66a: 70 MHz
Number of carriers per pipe	Up to 8 carriers in total for all supported RATs
Supported bandwidths	LTE: 1.4, 3, 5, 10, 15, 20 MHz 5G: 5, 10, 15, 20 MHz
PIM cancellation	Yes

Interfaces

Figure 80 AHFIC interfaces

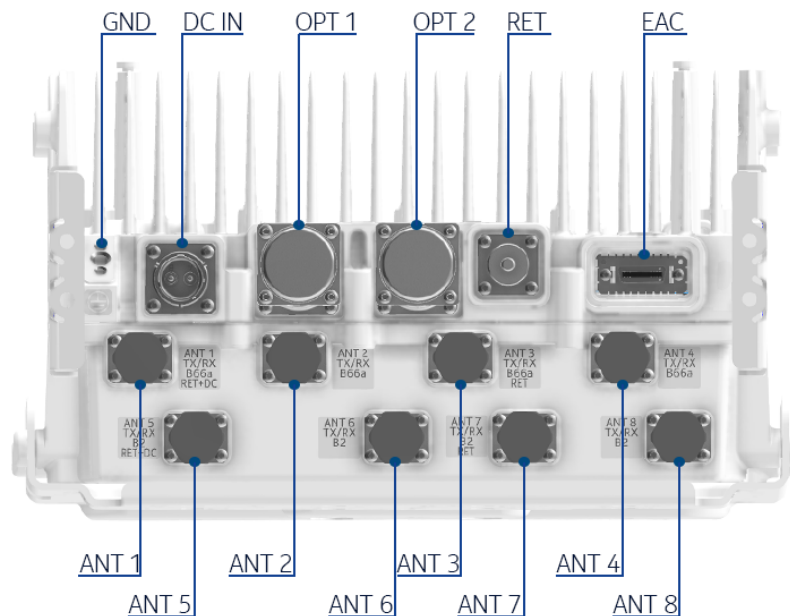



Table 303 AHFIC interfaces

Interface	Label on the HW	Number of interfaces	Connector type	Additional info
Power Connector	DC IN	1	High power circular	APPB, APPC
Antenna connector	ANT	8	4.3-10	AISG on all ports, BiasT support on ANT1 & ANT5 Has features that prevent damage if mating with a 4.1-9.5 connector is attempted
Remote Electrical Tilt	RET	1	8-pin circular	RS-485
External Alarm Connection	EAC	1	MDR-26	4 alarm inputs and 1 control output
Optical interface	OPT	2	SFP+ (R2CT)	9.8 Gbps, CPRI; R2CT IP seal
Ground		1	M8 or dual M5 screws	-
Fan	FAN	1	Nokia fan	Located on the heat sink side



WARNING! Risk of electric shock

Before turning RF power on, RF ports have to be terminated by nominal 50 Ω load (for example, feeder with antenna). However, if these conditions are not met, the plastic caps that are delivered within the unused RF ports should remain in place. The plastic caps isolate RF port from the environment, and thus provide electric shock security in case RF power is accidentally on.

Antenna Line Devices (ALDs) support

Table 304 AHFIC ALD support

ALD support	Value
AISG	ANT1, ANT3, ANT5, ANT7: AISG 2.0/3.0
CWA (for non-AISG installations)	No
Voltage	14.5 V (ANT1 and ANT5 only)
Power per port	45W max per ANT, 30W max for four MHAs, 75 W total

Functional block diagram

Figure 81 AHFIC functional block diagram

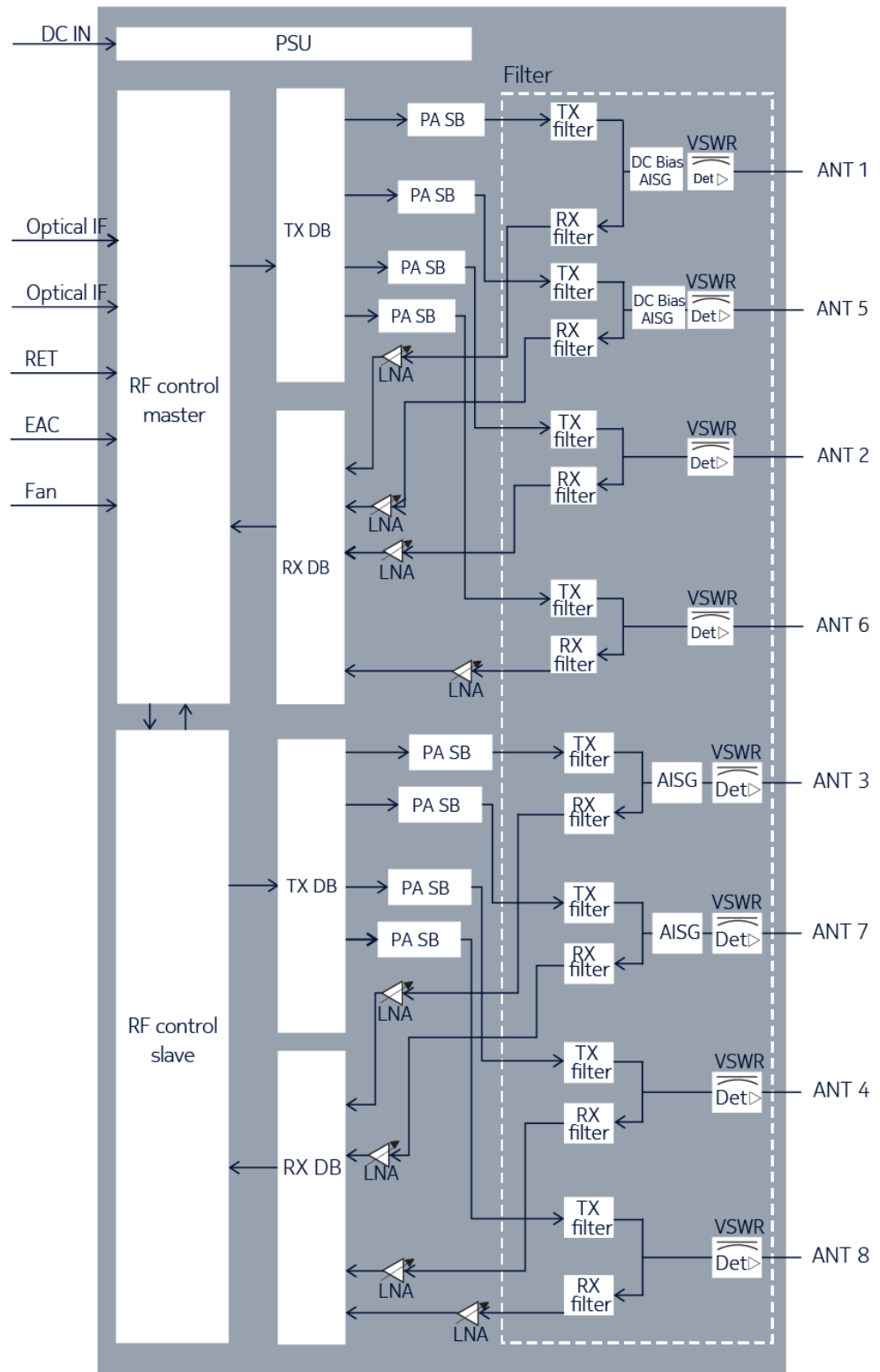

Electrical specifications

Table 305 AHFIC electrical specifications

Property	Value
Nominal supply voltage	-48.0 V DC
Nominal input voltage range	-40.5 V DC to -57.0 V DC
Extended input voltage range	-36.0 V DC to -40.5 V DC -57.0 V DC to -60.0 V DC



Note: The minimum start-up voltage is -40.5 V DC. If the input voltage is below/beyond the extended limits, the unit might shut down.

Power consumption

Typical power consumption [W] for 48VDC input, at 25°C, representative of typical product performance under the same conditions (HW variant, SW version, configuration, environment, and so on) with +/- 10% margin. Average = (6h low hour load, 10h medium hour load and 8h busy hour load) / 24h

Configurations explained on examples:

- GSM/WCDMA: 2/2/2 = three sectors, two carriers/TRXs per sector
- LTE:
 - o 2/2/2 2Tx = three sectors, two carriers per sector, 2Tx per carrier
 - o 1+1/1+1/1+1 4Tx = three dual-band sectors, one carrier per sector per band, 4Tx per carrier

Some radio units are capable of providing only one sector coverage. Then the power values in the table consider deployment of three radio units.

Table 306 AHFIC power consumption

Configuration	Output power per carrier (W)	Power consumption (W) ETSI 202706 average P _{RRH, static}	Power consumption (W) ETSI 202706 busy hour load P _{BH RRH, static}	Power consumption (W) 100% RF power load P _{100% RRH}
Single band 1/1/1 4Tx	4x40	1364	1605	2111
Single band 1/1/1 4Tx	4x20	1162	1300	1569
Single band 1/1/1 2Tx	2x40	960	1075	1316
Single band 1/1/1 2Tx	2x20	865	932	1058
Dual band 1+1 / 1+1 / 1+1 4Tx	4x40	2144	2627	3715
Dual band 1+1 / 1+1 / 1+1 4Tx	4x20	1756	2033	2569

Table 306 AHFIC power consumption (Cont.)

Configuration	Output power per carrier (W)	Power consumption (W) ETSI 202706 average P_{RRH} , static	Power consumption (W) ETSI 202706 busy hour load $P_{BH\ RRH}$, static	Power consumption (W) 100% RF power load $P_{100\% \ RRH}$
Dual band 1+1 / 1+1 / 1+1 2Tx	2x40	1364	1605	2111
Dual band 1+1 / 1+1 / 1+1 2Tx	2x20	1162	1300	1569

Power reduction

Table 307 Recommended AHFIC power reduction per band, in 256 QAM

Single carrier [dB]	Dual carrier [dB]	Triple carrier [dB]	Quad carrier [dB]
0	0.7	0.7	0.9



Note: The maximum power reduction (`dlCellPwrRed`) value is 20 dB. High power reduction values may cause radio outages.

Related optional items

- ASFC AirScale 2 fan unit 600 (474484A)
- AMBH AirScale book mount kit 176-200 (474280A)
- FPKA Flexi Pole Mounting Kit (30-120 mm) (471649A)
- FPKC Flexi Pole Mounting Kit (60-300 mm) (472821A)
- AMPA Pole Mounting Kit (30-120 mm) (473879A)
- AMFD AirScale 2 FPKx Fixing Adapter 600 (474293A)
- ASAA AirScale 2 MDR26-open EAC cable 5 m (474288A)
- APPB AirScale 2 55A DC plug 3.3-10 mm² (474282A)
- APPC AirScale 2 55A DC plug 10-16 mm² (474283A)
- ACPB AirScale 2 Fiber connector R2CT V2 (474384A)
- AMRB AirScale one clip bracket 126-200 (474581A)
- AMRC AirScale one clip rail 600 mm (474583A)

Installation options

- Wall installation
- Pole installation
- Vertical book mount
- Horizontal book mount (fan is required)
- One-clip rail installation



NOTICE: Install this RRH in a vertical orientation with connectors on the bottom side, to ensure convection cooling. For horizontal installation fans are required.

Dimensions and weight

Table 308 AHFIC dimensions and weight

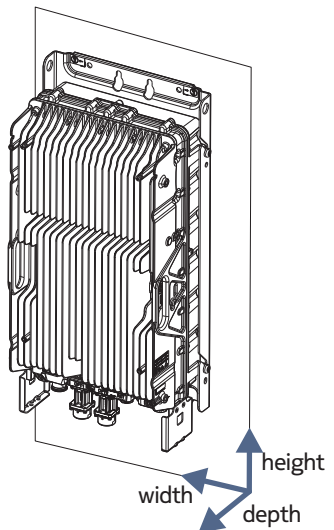
Property	Value	Dimensions orientation
Height	Core RRH: 560 mm (22.0 in.) With upper and lower mounting brackets: 675 mm (26.6 in.)	
Width	Core RRH: 308 mm (12.1 in.) With mounting brackets: 327 mm (12.9 in.)	
Depth	Core RRH: 177 mm (7.0 in.) With mounting brackets: 193 mm (7.6 in.)	
Weight	35 kg (77.2 lb)	

Environmental specifications

Table 309 AHFIC environmental specifications

Property	Value
Maximum operational outdoor temperature (in the shade) with fan or 10.8 km/h (6.7 mph) wind	55°C (131°F)
Maximum operational outdoor temperature (in the sun) with fan or 10.8 km/h (6.7 mph) wind	50°C (122°F)
Maximum indoor temperature	45°C (113°F)
Minimum operational temperature	-40°C (-40°F)
IP rating	IP65

LTE3845 feature interdependencies

The *LTE3845: Nokia AirScale Dual RRH 4T4R B2/66a 320 W* feature is impacted by the following features:

- *LTE112: Cell Bandwidth - 20 MHz* needs to be enabled to use LTE 20 MHz carriers.
- *LTE113: Cell Bandwidth - 15 MHz* needs to be enabled to use LTE 15 MHz carriers.
- *LTE114: Cell Bandwidth - 10 MHz* needs to be enabled to use LTE 10 MHz carriers.
- *LTE115: Cell Bandwidth - 5 MHz* needs to be enabled to use LTE 5 MHz carriers.
- *LTE116: Cell Bandwidth - 3 MHz* needs to be enabled to use LTE 3 MHz carriers.
- *LTE117: Cell Bandwidth - 1.4 MHz*

- needs to be enabled to use LTE 1.4 MHz carriers.
- With *LTE614: Distributed Site*, AHFIC can be used in distributed sites with up to 23 km fiber length to the system module.
- *LTE1103: Load based Power Saving for multi-layer networks* needs to be enabled to use Load based Power Saving for multi-layer networks.
- *LTE1203: Load based Power Saving with Tx path switching off* needs to be enabled to use Load based Power Saving with Tx path switching off.
- *LTE2508: BTS Embedded Power Meter for Energy Efficiency Monitoring* needs to be enabled to use BTS Embedded Power Meter for Energy Efficiency Monitoring.
- With *LTE2541: Nokia CPRI RRH/RFM chaining*, AHFIC supports Nokia CPRI chain of up to four radio units.
- *LTE2863: PIM Cancellation for AirScale 2.0 Radios* need to be enabled to activate PIM cancellation feature (licenced feature).
- *LTE3036: Micro DTX extension* needs to be enabled to use Micro DTX extension.

5.3.6 Nokia AirScale Dual RRH 4T4R B5/13 (n5) 160 W (AHBCA)

AHBCA is introduced by LTE3848, 5GC001151: Nokia AirScale Dual RRH 4T4R B5/13 (n5) 160 W (AHBCA).

Functional description

Table 310 AHBCA functional specification

Property	Value
Output power	4x40 W
QAM	256 QAM (DL) 64 QAM (UL)
Number of TXRX	B5/n5: 4T4R B13: 4T4R
Outdoor installation	Yes
Supported technologies (standalone and MSR)	B5, B13: FDD-LTE n5: 5G
TX frequency range	B5/n5: 869 MHz – 894 MHz B13: 746 MHz – 756 MHz
RX frequency range	B5/n5: 824 MHz – 849 MHz B13: 777 MHz – 787 MHz
DL filter bandwidth	B5/n5: 25 MHz B13: 10 MHz

Table 310 AHBCA functional specification (Cont.)

Property	Value
UL filter bandwidth	B5/n5: 25 MHz B13: 10 MHz
iBW (instantaneous bandwidth)	B5/n5: 25 MHz B13: 10 MHz
oBW (occupied bandwidth)	B5/n5: 25 MHz B13: 10 MHz
Number of carriers per pipe	Up to 4 carriers in total for all supported RATs
Supported bandwidths	1.4, 3, 5, 10 MHz 5G: 5, 10, 15, 20 MHz
PIM cancellation	Yes

Interfaces

Figure 82 AHBCA interfaces

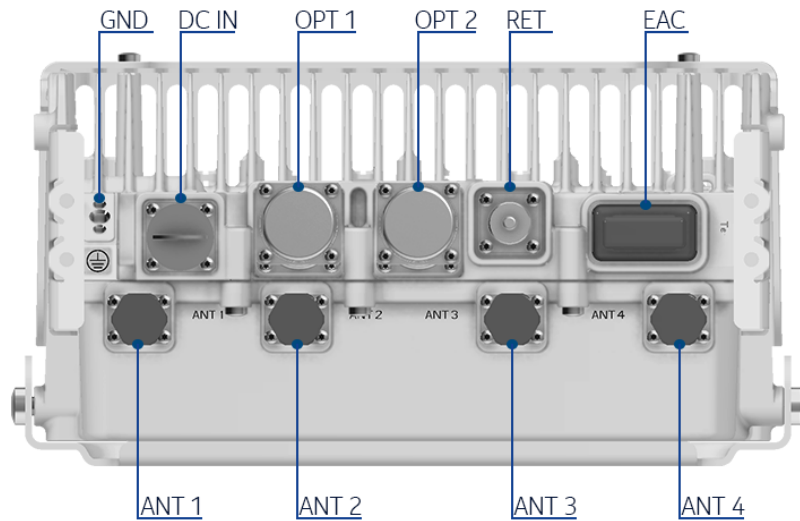



Table 311 AHBCA interfaces

Interface	Label on the HW	Number of interfaces	Connector type	Additional info
Power Connector	DC IN	1	High power circular	APPB, APPC
Antenna connector	ANT	4	4.3-10	-

Table 311 AHBCA interfaces (Cont.)

Interface	Label on the HW	Number of interfaces	Connector type	Additional info
Remote Electrical Tilt	RET	1	8-pin circular	RS-485
External Alarm Connection	EAC	1	MDR26	4 alarm inputs and 1 control output
Optical interface	OPT	2	SFP+ (R2CT)	9.8 Gbps, CPRI; R2CT IP seal
Grounding		1	M8 or dual M5 screws	-
Fan	FAN	4	Nokia fan	Located on the heat sink side

**WARNING! Risk of electric shock**

Before turning RF power on, RF ports have to be terminated by nominal 50 Ω load (for example, feeder with antenna). However, if these conditions are not met, the plastic caps that are delivered within the unused RF ports should remain in place. The plastic caps isolate RF port from the environment, and thus provide electric shock security in case RF power is accidentally on.

Antenna Line Devices (ALDs) support

Table 312 AHBCA ALD support

ALD support	Value
AISG	2.0, 3.0
CWA (for non-AISG installations)	No
Voltage	14.5 V (ANT1 and ANT3 only)
Power per port	30 W, 45 W total

Functional block diagram

Figure 83 AHBCA functional block diagram

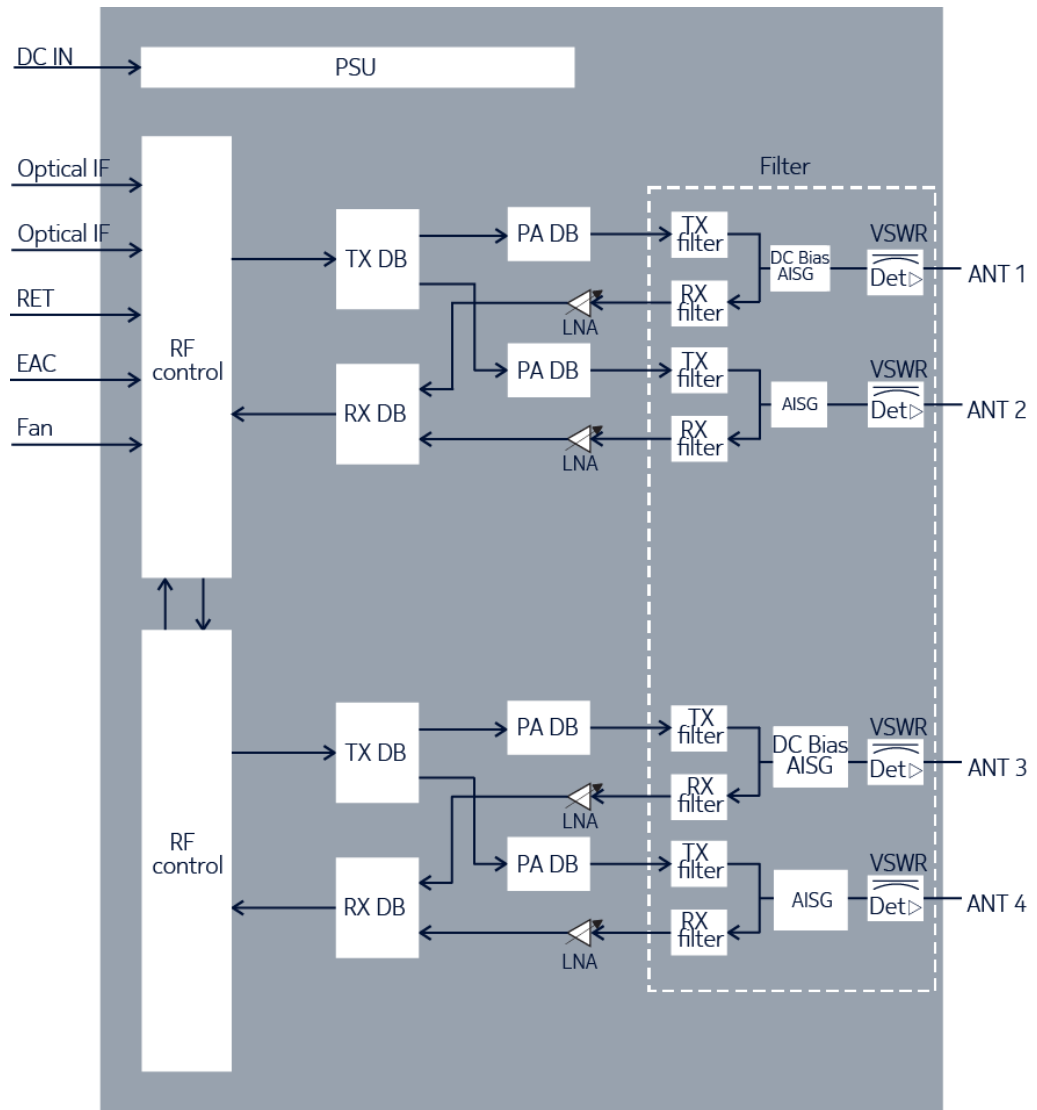

Electrical specifications

Table 313 AHBCA electrical specifications

Property	Value
Nominal supply voltage	-48.0 V DC
Nominal input voltage range	-40.5 V DC to -57.0 V DC
Extended input voltage range	-36.0 V DC to -40.5 V DC -57.0 V DC to -60.0 V DC



Note: The minimum start-up voltage is -40.5 V DC. If the input voltage is below/beyond the extended limits, the unit might shut down.

Power consumption

Typical power consumption [W] for 48VDC input, at 25°C, representative of typical product performance under the same conditions (HW variant, SW version, configuration, environment, and so on) with +/- 10% margin. Average = (6h low hour load, 10h medium hour load and 8h busy hour load) / 24h

Configurations explained on examples:

- GSM/WCDMA: 2/2/2 = three sectors, two carriers/TRXs per sector
- LTE:
 - o 2/2/2 2Tx = three sectors, two carriers per sector, 2Tx per carrier
 - o 1+1/1+1/1+1 4Tx = three dual-band sectors, one carrier per sector per band, 4Tx per carrier

Some radio units are capable of providing only one sector coverage. Then the power values in the table consider deployment of three radio units.

Table 314 AHBCA power consumption in LTE mode

Configuration	Output power per carrier (W)	Power consumption (W) ETSI 202706 average P _{RRH} , static	Power consumption (W) ETSI 202706 busy hour load P _{BH RRH} , static	Power consumption (W) 100% RF power load P _{100% RRH}
Single band 1/1/1 4Tx	4x40	1411	1660	2322
Single band 1/1/1 4Tx	4x30	1308	1496	1958
Single band 1/1/1 4Tx	4x20	1204	1334	1622
Dual band 1+1 / 1+1 / 1+1 4Tx	4x20	1415	1655	2247
Dual band 1+1 / 1+1 / 1+1 4Tx	4x15	1319	1506	1930
Dual band 1+1 / 1+1 / 1+1 4Tx	4x10	1216	1350	1624

Power reduction

Table 315 Recommended AHBCA power reduction in 256 QAM (carrier spacing over 100 MHz)

Single carrier [dB]	Dual carrier [dB]	Triple carrier [dB]	Quad carrier [dB]
0	0.8	0.8	0.8



Note: The maximum power reduction (dlCellPwrRed) value is 20 dB. High power reduction values may cause radio outages.

Related optional items

- ASFC AirScale 2 fan unit 600 (474484A)
- AMBG AirScale bookmount kit 151-175 (474279A)

- FPKA Flexi Pole Mounting Kit (30-120 mm) (471649A)
- FPKC Flexi Pole Mounting Kit (60-300 mm) (472821A)
- APAF AirScale AC-DC PSU 208-240VAC/1150W (474676A)
- AMPA Pole Mounting Kit (30-120 mm) (473879A)
- AMFD AirScale 2 FPKx Fixing Adapter 600 (474293A)
- ASAA AirScale 2 MDR26-open EAC cable 5 m (474288A)
- APPB AirScale 2 55A DC plug 3.3-10 mm² (474282A)
- APPC AirScale 2 55A DC plug 10-16 mm² (474283A)
- ACPB AirScale 2 Fiber connector R2CT V2 (474384A)
- AMRB AirScale one clip bracket 126-200 (474581A)
- AMRC AirScale one clip rail 600 mm (474583A)

Installation options

- Wall installation
- Pole installation
- Vertical book mount
- Horizontal book mount
- One-clip rail installation



NOTICE: Install this RRH in a vertical orientation with connectors on the bottom side, to ensure convection cooling. For horizontal installation fans are required.

Dimensions and weight

Table 316 AHBCA dimensions and weight

Property	Value	Dimensions orientation
Height	Core RRH: 560 mm (22.0 in.) With mounting brackets: 675 mm (26.6 in.)	
Width	308 mm (12.1 in.) With mounting brackets: 327 mm (12.9 in.)	
Depth	Core RRH: 157 mm (6.2 in.) With mounting brackets: 173 mm (6.8 in.)	
Weight	34 kg (74.9 lb)	

Environmental specifications

Table 317 AHBCA environmental specifications

Property	Value
Maximum operational outdoor temperature (in the shade) with fan or 10.8 km/h (6.7 mph) wind	55°C (131°F)

Table 317 AHBCA environmental specifications (Cont.)

Property	Value
Maximum operational outdoor temperature (in the sun) with fan or 10.8 km/h (6.7 mph) wind	50°C (131°F)
Maximum indoor temperature	45°C (113°F)
Minimum operational temperature	-40°C (-40°F)
IP rating	IP65

LTE3848 feature interdependencies

The *LTE3848: AirScale Dual RRH 4T4R B5/13 160 W (AHBCA)* feature is impacted by the following features:

- With *LTE614* AHBCA uses in distributed sites with up to 23 km fiber length to the system module.
- *LTE1103* enables to use Load based Power Saving for multi-layer networks.
- *LTE114* enables to use LTE 10 MHz carriers.
- *LTE115* enables to use LTE 5 MHz carriers.
- *LTE116* enables to use LTE 3 MHz carriers.
- *LTE117* enables to use LTE 1.4 MHz carriers.
- *LTE1203* enables to use Load based Power Saving with Tx path switching off.
- *LTE2428* provides support for CPRI interface.
- *LTE2508* enables to use BTS Embedded Power Meter for Energy Efficiency Monitoring.
- With *LTE2541* AHBCA supports Nokia CPRI chain of up to 4 radio units.
- *LTE2863* enables to activate PIM cancellation feature (licenced feature).
- *LTE3036* enables to use Micro DTX extension.

5.3.7 Nokia AirScale Dual RRH 4T4R B5/13 320 W (AHBCC)

AHBCC is introduced by LTE3849: Nokia AirScale Dual RRH 4T4R B5/13 320 W (AHBCC).

Functional description

Table 318 AHBCC functional specification

Property	Value
Output power	4x80 W with up to 4x40 W for single band operation
QAM	256 QAM (DL) 64 QAM (UL)
Number of TXRX	B5: 4T4R B13: 4T4R

Table 318 AHBCC functional specification (Cont.)

Property	Value
Outdoor installation	Yes
Supported technologies (standalone and MSR)	FDD-LTE, 5G-ready
IoT support	B13: NB-IoT in band, guard band (GB), standalone (SA)
TX frequency range	B5: 869 - 894 MHz B13: 746 - 756 MHz
RX frequency range	B5: 824 - 849 MHz B13: 777 - 787 MHz
DL filter bandwidth	B5: 25 MHz B13: 10 MHz
UL filter bandwidth	B5: 25 MHz B13: 10 MHz
iBW (instantaneous bandwidth)	B5: 25 MHz B13: 10 MHz
oBW (occupied bandwidth)	B5: 25 MHz B13: 10 MHz
Number of carriers per pipe	Up to 8
Supported bandwidths	B5: 1.4, 3, 5, 10 MHz B13: 5, 10 MHz
PIM cancellation	Yes

Interfaces

Figure 84 AHBCC interfaces

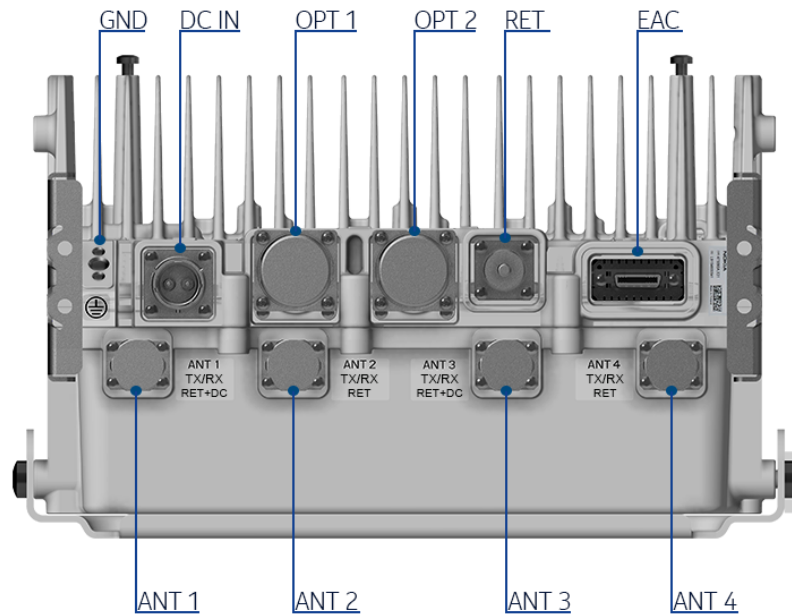



Table 319 AHBCC interfaces

Interface	Label on the HW	Number of interfaces	Connector type	Additional info
Power Connector	DC IN	1	High power circular	APPB, APPC
Antenna connector	ANT	4	4.3-10	AISG on all ports, BiasT support on ANT1 and ANT3 Has features that prevent damage if mating with a 4.1-9.5 connector is attempted
Remote Electrical Tilt	RET	1	8-pin circular	RS-485
External Alarm Connection	EAC	1	MDR-26	4 alarm inputs and 1 control output
Optical interface	OPT	2	SFP+ (R2CT)	9.8 Gbps, CPRI; R2CT IP seal
Grounding		1	M5 or dual M8	-
Fan	FAN	1	Nokia fan	Located on the heat sink side



WARNING! Risk of electric shock

Before turning RF power on, RF ports have to be terminated by nominal 50 Ω load (for example, feeder with antenna). However, if these conditions are not met, the plastic caps that are delivered within the unused RF ports should remain in place. The plastic caps isolate RF port from the environment, and thus provide electric shock security in case RF power is accidentally on.

Antenna Line Devices (ALDs) support

Table 320 AHBCC ALD support

ALD support	Value
AISG	2.0, 3.0
CWA (for non-AISG installations)	No
Voltage	14.5 V (ANT1 and ANT3 only)
Power per port	30 W, 45 W total

Functional block diagram

Figure 85 AHBCC functional block diagram

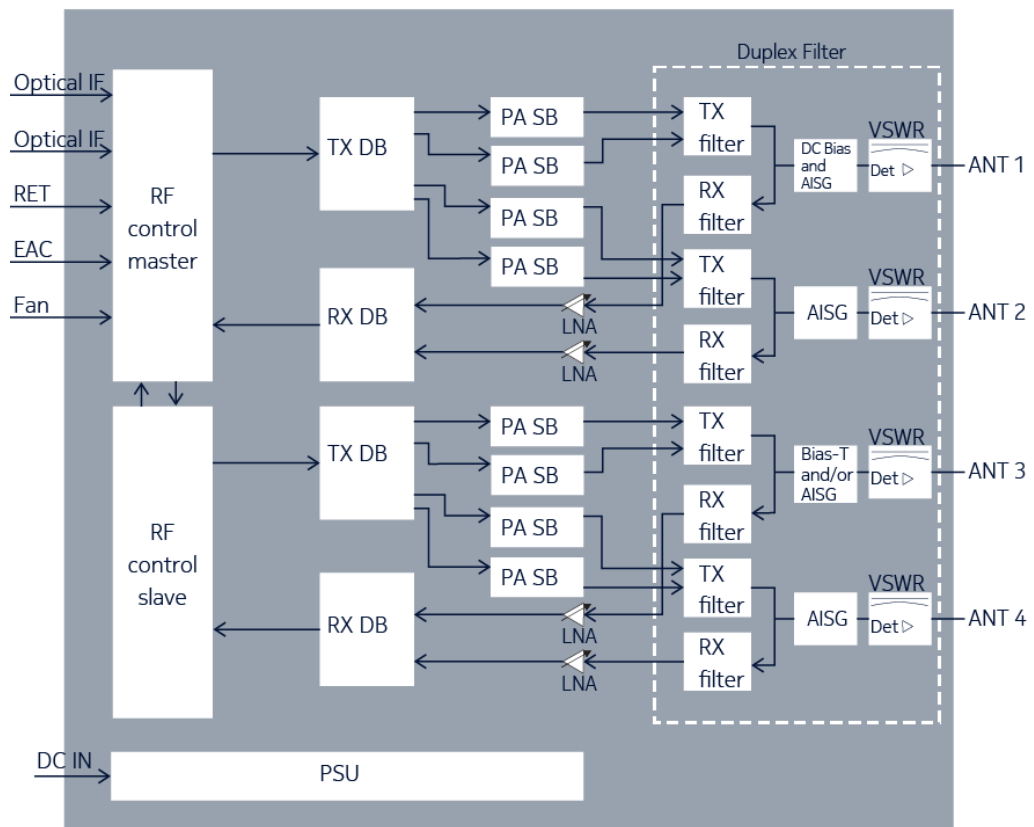

Electrical specifications

Table 321 AHBCC electrical specifications

Property	Value
Nominal supply voltage	-48.0 V DC

Table 321 AHBCC electrical specifications (Cont.)

Property	Value
Nominal input voltage range	-40.5 V DC to -57.0 V DC
Extended input voltage range	-36.0 V DC to -40.5 V DC -57.0 V DC to -60.0 V DC



Note: The minimum start-up voltage is -40.5 V DC. If the input voltage is below/beyond the extended limits, the unit might shut down.

Power consumption

Typical power consumption [W] for 48VDC input, at 25°C, representative of typical product performance under the same conditions (HW variant, SW version, configuration, environment, and so on) with +/- 10% margin. Average = (6h low hour load, 10h medium hour load and 8h busy hour load) / 24h

Configurations explained on examples:

- GSM/WCDMA: 2/2/2 = three sectors, two carriers/TRXs per sector
- LTE:
 - o 2/2/2 2Tx = three sectors, two carriers per sector, 2Tx per carrier
 - o 1+1/1+1/1+1 4Tx = three dual-band sectors, one carrier per sector per band, 4Tx per carrier

Some radio units are capable of providing only one sector coverage. Then the power values in the table consider deployment of three radio units.

Table 322 AHBCC power consumption in LTE mode

Configuration	Output power per carrier (W)	Power consumption (W) ETSI 202706 average P_{RRH} , static	Power consumption (W) ETSI 202706 busy hour load $P_{BH\ RRH}$, static	Power consumption (W) 100% RF power load $P_{100\% \ RRH}$
Single band 1/1/1 4Tx	4x40	1302	1509	1980
Single band 1/1/1 4Tx	4x30	1217	1377	1731
Single band 1/1/1 4Tx	4x20	1126	1239	1468
Dual band 1+1 / 1+1 / 1+1 4Tx	4x40	2024	2465	3493
Dual band 1+1 / 1+1 / 1+1 4Tx	4x30	1856	2195	2960
Dual band 1+1 / 1+1 / 1+1 4Tx	4x20	1666	1905	2392

Power reduction

Table 323 Recommended AHBCB power reduction per band, in 256 QAM (carrier spacing over 100 MHz)

Single carrier [dB]	Dual carrier [dB]	Triple carrier [dB]	Quad carrier [dB]
0	0.8	0.8	0.8



Note: The maximum power reduction (`dlCellPwrRed`) value is 20 dB. High power reduction values may cause radio outages.

Related optional items

- ASFC AirScale 2 fan unit 600 (474484A)
- AMBH AirScale book mount kit 176-200 (474280A)
- FPKA Flexi Pole Mounting Kit (30-120 mm) (471649A)
- FPKC Flexi Pole Mounting Kit (60-300 mm) (472821A)
- AMPA Pole Mounting Kit (30-120 mm) (473879A)
- AMFD AirScale 2 FPKx Fixing Adapter 600 (474293A)
- ASAA AirScale 2 MDR26-open EAC cable 5 m (474288A)
- APPB AirScale 2 55A DC plug 3.3-10 mm² (474282A)
- APPC AirScale 2 55A DC plug 10-16 mm² (474283A)
- ACPB AirScale 2 Fiber connector R2CT V2 (474384A)
- AMRC AirScale one clip rail 600 mm (474583A)
- AMRD AirScale one clip bracket over 200 (474582A)

Installation options

- Wall installation
- Pole installation
- Vertical book mount
- Horizontal book mount (fan is required)
- One-clip rail installation



NOTICE: Install this RRH in a vertical orientation with connectors on the bottom side, to ensure convection cooling. For horizontal installation fans are required.

Dimensions and weight

Table 324 AHBCC dimensions and weight

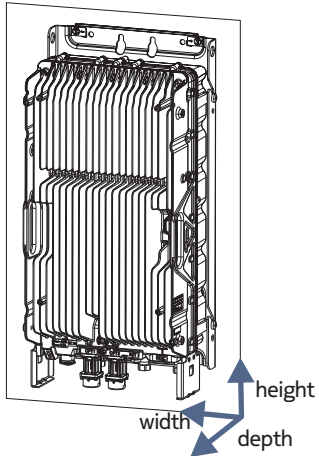
Property	Value	Dimensions orientation
Height	Core RRH: 560 mm (22.0 in.) With upper and lower mounting brackets: 675 mm (26.6 in.)	
Width	Core RRH: 308 mm (12.1 in.) With mounting brackets: 327 mm (12.9 in.)	
Depth	Core RRH: 189 mm (7.4 in.) With mounting brackets: 205 mm (8.1 in.)	
Weight	38 kg (83.8 lbs)	

Environmental specifications

Table 325 AHBCC environmental specifications

Property	Value
Maximum operational outdoor temperature (in the shade) with fan or 10.8 km/h (6.7 mph) wind	55°C (131°F)
Maximum operational outdoor temperature (in the sun) with fan or 10.8 km/h (6.7 mph) wind	50°C (122°F)
Maximum indoor temperature	45°C (113°F)
Minimum operational temperature	-40°C (-40°F)
IP rating	IP65

LTE3849 feature interdependencies

The *LTE3849: Nokia AirScale Dual RRH 4T4R B5/13 320 W* feature is impacted by the following features:

- *LTE114: Cell Bandwidth - 10 MHz* needs to be enabled to use LTE 10 MHz carriers.
- *LTE115: Cell Bandwidth - 5 MHz* needs to be enabled to use LTE 5 MHz carriers.
- *LTE116: Cell Bandwidth - 3 MHz* needs to be enabled to use LTE 3 MHz carriers.
- *LTE117: Cell Bandwidth - 1.4 MHz* needs to be enabled to use LTE 1.4 MHz carriers.
- With *LTE614: Distributed Site*, AHBCC can be used in distributed sites with up to 23 km fiber length to the system module.
- *LTE1103: Load based Power Saving for multi-layer networks* needs to be enabled to use Load based Power Saving for multi-layer networks

- *LTE1203: Load based Power Saving with Tx path switching off* needs to be enabled to use Load based Power Saving with Tx path switching off.
- *LTE2508: BTS Embedded Power Meter for Energy Efficiency Monitoring* needs to be enabled to use BTS Embedded Power Meter for Energy Efficiency Monitoring.
- With *LTE2541: Nokia CPRI RRH/RFM chaining*, AHBCC supports Nokia CPRI chain of up to four radio units.
- *LTE2863: PIM Cancellation for AirScale 2.0 Radios* needs to be enabled to activate PIM cancellation feature (licenced feature).
- *LTE3036: Micro DTX extension* needs to be enabled to use Micro DTX extension.

5.3.8 Nokia AirScale Dual RRH 4T4R B5/28 (n5/n28) 320 W (AHPCA)

AHPCA is introduced by LTE5209, SR002356, 5GC002593: AirScale Dual RRH 4T4R B5/28 (n5/n28) 320 W (AHPCA).

Functional description

Table 326 AHPCA functional specification

Property	Value
Output power	4x80 W with up to 4x40 W for single band operation
QAM	256 QAM (DL) 64 QAM (UL)
Number of TXRX	B5/n5: 4T4R B28/n28: 4T4R
Outdoor installation	Yes
Supported technologies (standalone and MSR)	B5: GSM, WCDMA, FDD-LTE, GSM-WCDMA, GSM-LTE, WCDMA-LTE, GSM-WCDMA-LTE B28: FDD-LTE n5/n28: 5G
IoT support	NB-IoT in band, guard band (GB), standalone (SA)
TX frequency range	B5/n5: 869–894 MHz B28/n28: 758–803 MHz
RX frequency range	B5/n5: 824–849 MHz B28/n28: 703–748 MHz
DL filter bandwidth	B5/n5: 25 MHz

Table 326 AHPCA functional specification (Cont.)

Property	Value
	B28/n28: 45 MHz
UL filter bandwidth	B5/n5: 25 MHz B28/n28: 45 MHz
iBW (instantaneous bandwidth)	B5/n5: 25 MHz B28/n28: 45 MHz
oBW (occupied bandwidth)	B5/n5: 25 MHz B28/n28: 45 MHz
Number of carriers per pipe	Up to 8 carriers in total for all supported RATs
Supported bandwidths	B5: 1.4, 3, 5, 10 MHz B28: 3, 5, 10, 15, 20 MHz n5/n28: 5, 10, 15, 20 MHz
PIM cancellation	Yes

Interfaces

Figure 86 AHPCA interfaces

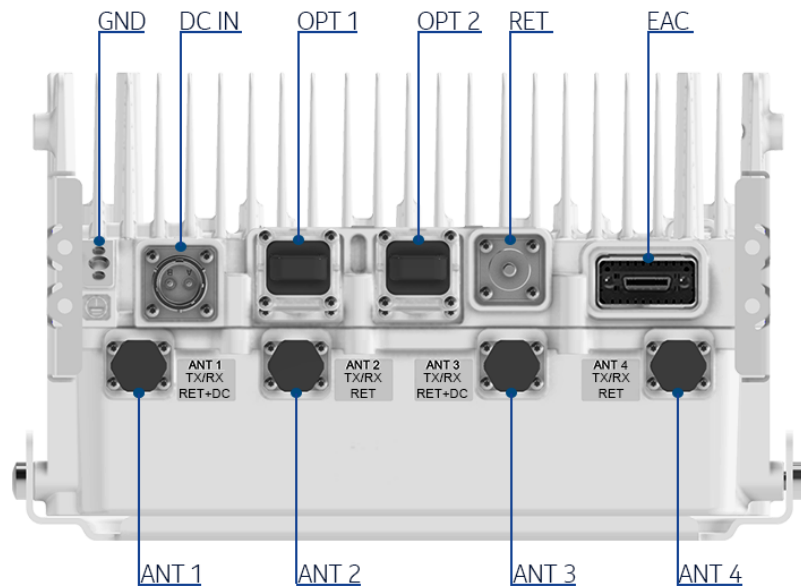



Table 327 AHPCA interfaces

Interface	Label on the HW	Number of interfaces	Connector type	Additional info
Power Connector	DC IN	1	High power circular	APPB, APPC
Antenna connector	ANT	4	4.3-10	AISG on all ports and BiasT support on ANT1 & ANT3; has features that prevent damage if mating with a 4.1-9.5 connector is attempted
Remote Electrical Tilt	RET	1	8-pin circular	RS-485
External Alarm Connection	EAC	1	MDR-26	4 alarm inputs and 1 control output
Optical interface	OPT	2	SFP+	9.8 Gbps, CPRI; Nokia IP seal
Grounding		1	M8 or dual M5 screws	-
Fan	FAN	1	Nokia fan	Located on the heat sink side



WARNING! Risk of electric shock

Before turning RF power on, RF ports have to be terminated by nominal 50 Ω load (for example, feeder with antenna). However, if these conditions are not met, the plastic caps that are delivered within the unused RF ports should remain in place. The plastic caps isolate RF port from the environment, and thus provide electric shock security in case RF power is accidentally on.

Antenna Line Devices (ALDs) support

Table 328 AHPCA ALD support

Property	Value
AISG	2.0, 3.0
CWA (for non-AISG installations)	No
Voltage	14.5 V (ANT1 and ANT3 only)
Power per port	30 W, 45 W total

Functional block diagram

Figure 87 AHPCA functional block diagram

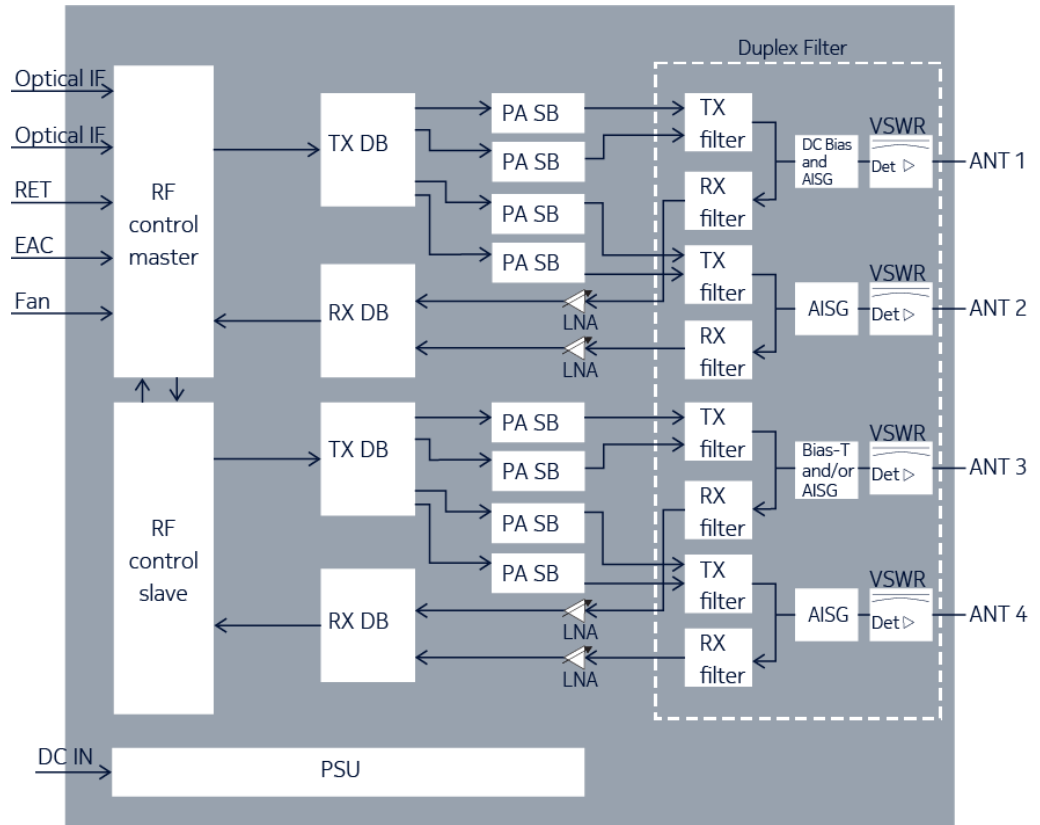

Electrical specifications

Table 329 AHPCA electrical specifications

Property	Value
Nominal supply voltage	-48.0 V DC
Nominal input voltage range	-40.5 V DC to -57.0 V DC
Extended input voltage range	-36.0 V DC to -40.5 V DC -57.0 V DC to -60.0 V DC

i **Note:** The minimum start-up voltage is -40.5 V DC. If the input voltage is below/beyond the extended limits, the unit might shut down.

Power consumption

i **Note:** AHPCA power consumption will be provided in future releases.

Power reduction

Table 330 Recommended AHPCA power reduction in 256 QAM

Single carrier [dB]	Dual carrier [dB]	Triple carrier [dB]	Quad carrier [dB]
0	0.8	0.8	0.8



Note: The maximum power reduction ($d1CellPwrRed$) value is 20 dB. High power reduction values may cause radio outages.

Related optional items

- ASFC AirScale 2 fan unit 600 (474484A)
- AMBH AirScale book mount kit 176-200 (474280A)
- FPKA Flexi Pole Mounting Kit (30-120 mm) (471649A)
- FPKC Flexi Pole Mounting Kit (60-300 mm) (472821A)
- AMPA Pole Mounting Kit (30-120 mm) (473879A)
- AMFD AirScale 2 FPKx Fixing Adapter 600 (474293A)
- ASAA AirScale 2 MDR26-open EAC cable 5 m (474288A)
- APPB AirScale 2 55A DC plug 3.3-10 mm² (474282A)
- APPC AirScale 2 55A DC plug 10-16 mm² (474283A)
- AMRC AirScale one clip rail 600 mm (474583A)
- AMRD AirScale one clip bracket over 200 (474582A)
- ACPA AirScale 2 Fiber Protection (474297A)

Installation options

- Wall installation
- Pole installation
- Vertical book mount
- Horizontal book mount
- One-clip rail installation



NOTICE: Install this RRH in a vertical orientation with connectors on the bottom side, to ensure convection cooling. For horizontal installation fans are required.

Dimensions and weight

Table 331 AHPCA dimensions and weight

Property	Value	Dimensions orientation
Height	Core RRH: 560 mm (22.04 in.) With upper and lower mounting brackets: 675 mm (26.57 in.)	
Width	Core RRH: 308 mm (12.13 in.) With mounting brackets: 327 mm (12.87 in.)	
Depth	Core RRH: 189 mm (7.44 in.) With mounting brackets: 205 mm (8.07 in.)	
Weight	Core RRH: 38 kg (83.7 lb)	
Volume	Core RRH: 33 l	

Environmental specifications

Table 332 AHPCA environmental specifications

Property	Value
Maximum operational outdoor temperature (in the shade) with fan or 10.8 km/h (6.7 mph) wind	55°C (131°F)
Maximum operational outdoor temperature (in the sun) with fan or 10.8 km/h (6.7 mph) wind	50°C (122°F)
Maximum indoor temperature	45°C (113°F)
Minimum operational temperature	-40°C (-40°F)
IP rating	IP65

LTE5209 feature interdependencies

The *LTE5209: AirScale dual RRH 4T4R B5/28 320 W (AHPCA)* feature is impacted by the following features:

- *LTE112: Cell Bandwidth - 20 MHz* needs to be enabled to use LTE 20 MHz carriers.
- *LTE113: Cell Bandwidth - 15 MHz* needs to be enabled to use LTE 15 MHz carriers.
- *LTE114: Cell Bandwidth - 10 MHz* needs to be enabled to use LTE 10 MHz carriers.
- *LTE115: Cell Bandwidth - 5 MHz* needs to be enabled to use LTE 5 MHz carriers.
- *LTE116: Cell Bandwidth - 3 MHz* needs to be enabled to use LTE 3 MHz carriers.
- *LTE117: Cell Bandwidth - 1.4 MHz* needs to be enabled to use LTE 1.4 MHz carriers.
- With *LTE614: Distributed Site*, AHPCA can be used in distributed sites with up to 23 km fiber length to the system module.
- *LTE1103: Load based Power Saving for multi-layer networks* works when enabled in the settings.
- *LTE1203: Load based Power Saving with Tx path switching off* works when enabled in the settings.
- *LTE2508: BTS Embedded Power Meter for Energy Efficiency Monitoring* works when enabled in the settings.
- With *LTE2541: Nokia CPRI RRH/RFM chaining*, AHPCA supports Nokia CPRI chain of up to four radio units.
- *LTE2863: PIM Cancellation for AirScale 2.0 Radios* needs to be enabled to activate PIM cancellation feature (licenced feature).
- *LTE3036: Micro DTX extension* works when enabled in the settings.
- *LTE3037: Power Saving - Slow Drain Voltage Modulation* needs to be enabled to use load based PA efficiency improvement - SDVM.

5.3.9 Nokia AirScale Dual RRH 4T4R B5/29 240 W (AHBCB)

AHBCB is introduced by LTE3846/SR001095: Nokia AirScale Dual RRH 4T4R B5/29 240 W (AHBCB).

Functional description

Table 333 AHBCB functional specification

Property	Value
Output power	Up to 240 W in total with virtual WB (4x40 W + 2x40 W) B5: 4x40 W B29: 2x40 W
QAM	256 QAM (DL) 64 QAM (UL)
Number of TXRX	B5: 4T4R B29: 2T
Outdoor installation	Yes
Supported technologies (standalone and MSR)	FDD-LTE, 5G-ready
TX frequency range	B5: 869 - 894 MHz B29: 717 - 728 MHz
RX frequency range	B5: 824 - 849 MHz B29: not supported
DL filter bandwidth	B5: 25 MHz B29: 11 MHz
UL filter bandwidth	B5: 25 MHz B29: not supported
DL iBW (instantaneous bandwidth)	B5: 25 MHz B29: 11 MHz
UL iBW (instantaneous bandwidth)	B5: 25 MHz B29: not supported
DL oBW	B5: 25 MHz B29: 11 MHz
UL oBW	B5: 25 MHz B29: not supported

Table 333 AHBCB functional specification (Cont.)

Property	Value
Number of carriers per pipe	B5: up to 4 B29: up to 2
Supported bandwidths	B5: 1.4, 3, 5, 10 MHz B29: 5, 10 MHz
PIM cancellation	Yes

Interfaces

Figure 88 AHBCB interfaces

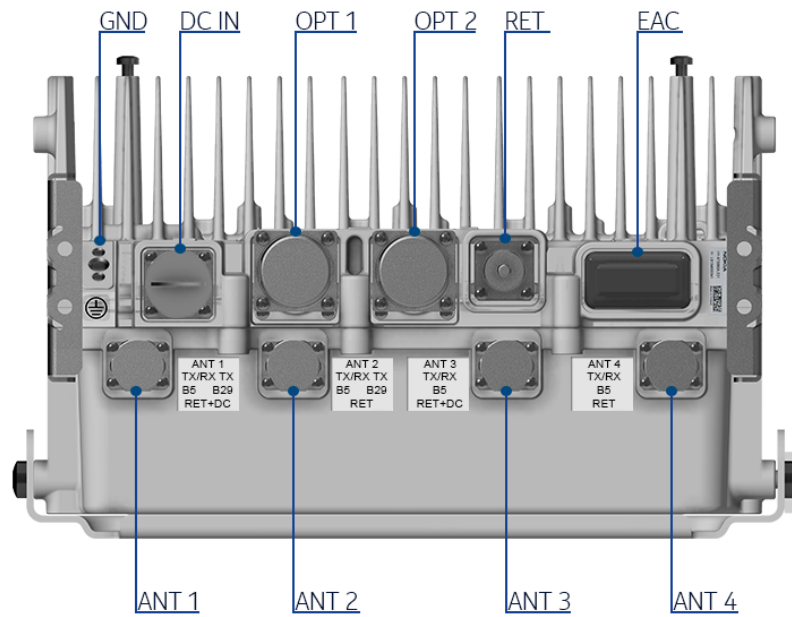



Table 334 AHBCB interfaces

Interface	Label on the HW	Number of interfaces	Connector type	Additional info
Power Connector	DC IN	1	High power circular	APPB, APPC
Antenna connector	ANT	4	4.3-10+	AISG on all ports, BiasT support on ANT1 and ANT3; has features that prevent damage if mating with a 4.1-9.5 connector is attempted
Remote Electrical Tilt	RET	1	8-pin circular	RS-485

Table 334 AHBCB interfaces (Cont.)

Interface	Label on the HW	Number of interfaces	Connector type	Additional info
External Alarm Connection	EAC	4	MDR-26	4 inputs and 1 control output
Optical interface	OPT	2	SFP+ (R2CT)	9.8 Gbps, CPRI; R2CT IP seal
Grounding		1	M8 or dual M5 screws	-
Fan	FAN	1	Nokia fan	Located on the heat sink side



WARNING! Risk of electric shock

Before turning RF power on, RF ports have to be terminated by nominal 50 Ω load (for example, feeder with antenna). However, if these conditions are not met, the plastic caps that are delivered within the unused RF ports should remain in place. The plastic caps isolate RF port from the environment, and thus provide electric shock security in case RF power is accidentally on.

Antenna Line Devices (ALDs) support

Table 335 AHBCB ALD support

Property	Value
AISG	2,0 3.0
CWA (for non-AISG installations)	No
Voltage	14.5 V (ANT1 and ANT3 only)
Power per port	30 W, 45 W total

Functional block diagram

Figure 89 AHBCB functional block diagram

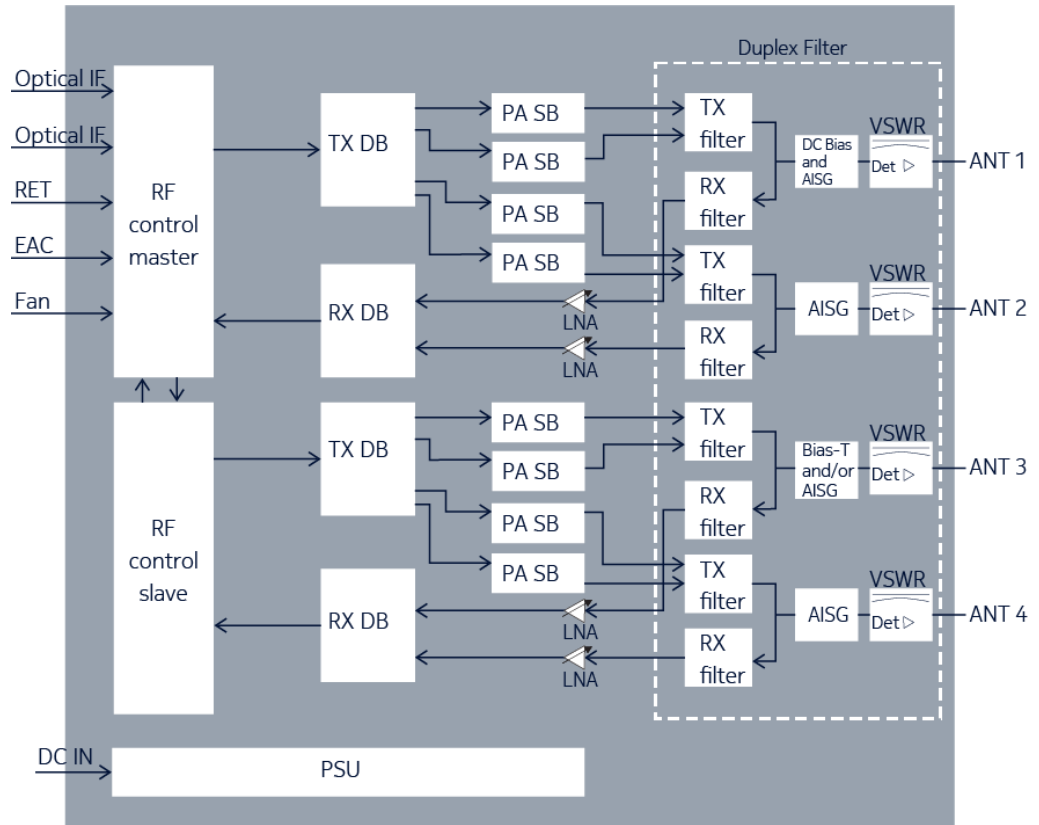

Electrical specifications

Table 336 AHBCB electrical specifications

Property	Value
Nominal supply voltage	-48.0 V DC
Nominal input voltage range	-40.5 V DC to -57.0 V DC
Extended input voltage range	-36.0 V DC to -40.5 V DC -57.0 V DC to -60.0 V DC

Note: The minimum start-up voltage is -40.5 V DC. If the input voltage is below/beyond the extended limits, the unit might shut down.

Power consumption

Note: AHBCB power consumption will be provided in future releases.

Power reduction

Note: The maximum power reduction (dlCellPwrRed) value is 20 dB. High power reduction values may cause radio outages.

Related optional items

- ASFC AirScale 2 fan unit 600 (474484A)
- AMBH AirScale book mount kit 176-200 (474280A)
- FPKA Flexi Pole Mounting Kit (30-120 mm) (471649A)
- FPKC Flexi Pole Mounting Kit (60-300 mm) (472821A)
- AMPA Pole Mounting Kit (30-120 mm) (473879A)
- AMFD AirScale 2 FPKx Fixing Adapter 600 (474293A)
- ASAA AirScale 2 MDR26-open EAC cable 5 m (474288A)
- APPB AirScale 2 55A DC plug 3.3-10 mm² (474282A)
- APPC AirScale 2 55A DC plug 10-16 mm² (474283A)
- ACPB AirScale 2 Fiber connector R2CT V2 (474384A)
- AMRC AirScale one clip rail 600 mm (474583A)
- AMRD AirScale one clip bracket over 200 (474582A)

Installation options

- Wall installation
- Pole installation
- Vertical book mount
- Horizontal book mount (fan is required)
- One-clip rail installation



NOTICE: Install this RRH in a vertical orientation with connectors on the bottom side, to ensure convection cooling. For horizontal installation fans are required.

Dimensions and weight

Table 337 AHBCB dimensions and weight

Property	Value	Dimensions orientation
Height	Core RRH: 560 mm (22.05 in.) With upper and lower mounting brackets: 675 mm (26.57 in.)	
Width	Core RRH: 308 mm (12.13 in.) With mounting brackets: 327 mm (12.87 in.)	
Depth	Core RRH: 189 mm (7.44 in.) With mounting brackets: 205 mm (8.07 in.)	
Weight	Core RRH: 38 kg (83.7 lb)	
Volume	Core RRH: 33 l	

Environmental specifications

Table 338 AHBCB environmental specifications

Property	Value
Maximum operational outdoor temperature (in the shade) with fan or 10.8 km/h (6.7 mph) wind	55°C (131°F)
Maximum operational outdoor temperature (in the sun) with fan or 10.8 km/h (6.7 mph) wind	50°C (122°F)
Maximum indoor temperature	45°C (113°F)
Minimum operational temperature	-40°C (-40°F)
IP rating	IP65

LTE3846 feature interdependencies

The *LTE3846: Nokia AirScale Dual RRH 4T4R B5/29 240 W* feature is impacted by the following features:

- *LTE114: Cell Bandwidth - 10 MHz* needs to be enabled to use LTE 10 MHz carriers.
- *LTE115: Cell Bandwidth - 5 MHz* needs to be enabled to use LTE 5 MHz carriers.
- *LTE116: Cell Bandwidth - 3 MHz* needs to be enabled to use LTE 3MHz carriers.
- *LTE117: Cell Bandwidth - 1.4 MHz* needs to be enabled to use LTE 1.4MHz carriers.
- With *LTE614: Distributed Site*, AHBCB can be used in distributed sites with up to 23 km fiber length to the system module.
- *LTE1103: Load based Power Saving for multi-layer networks* works when enabled in the settings.
- *LTE1203: Load based Power Saving with Tx path switching off* works when enabled in the settings.
- *LTE2428: Nokia CPRI in FDD-LTE* provides support for CPRI interface.
- *LTE2508: BTS Embedded Power Meter for Energy Efficiency Monitoring* works when enabled in the settings.
- With *LTE2541: Nokia CPRI RRH/RFM chaining*, AHBCB supports Nokia CPRI chain of up to four radio units.
- With *LTE:2556: Flexi Multiradio BTS Rx-Sniffing enhancements* AHBCB supports Rx-Sniffing.
- *LTE2863: PIM Cancellation for AirScale 2.0 Radios* needs to be enabled to activate PIM cancellation feature (licenced feature).
- *LTE3036: Micro DTX extension* works when enabled in the settings.

5.3.10 Nokia AirScale Dual RRH 4T4R B8/28 (n8/n28) 480 W (AHPDA)

AHPDA is introduced by SR002869, 5GC002467: MSR support for AirScale Dual RRH 4T4R B8/28 (n8/n28) 480 W AHPDA.

Functional description

Table 339 AHPDA functional specification

Property	Value
Output power	B8/n8: 4x80 W B28/n28: 4x40 W Max power for RRH: 480 W
QAM	256 QAM (DL) 64 QAM (UL)
Number of TXRX	4T4R
Outdoor installation	Yes
Supported technologies (standalone and MSR)	B8: FDD-LTE, WCDMA, GSM, WCDMA-LTE, GSM-LTE, LTE-GSM-WCDMA B28: FDD-LTE n8/n28: 5G
IoT support	NB-IoT in band, guard band (GB), standalone (SA)
TX frequency range	B8/n8: 935–960 MHz B28/n28: 758–803 MHz
RX frequency range	B8/n8: 890–915 MHz B28/n28: 703–748 MHz
DL filter bandwidth	B8/n8: 25 MHz B28/n28: 45 MHz
UL filter bandwidth	B8/n8: 25 MHz B28/n28: 45 MHz
iBW (instantaneous bandwidth)	B8/n8: 25 MHz B28/n28: 45 MHz
oBW (occupied bandwidth)	B8/n8: 25 MHz B28/n28: 45 MHz
Number of carriers per pipe	B8/n8: up to 8 carriers for all supported RATs B28/n28: up to 4 carriers for all supported RATs

Table 339 AHPDA functional specification (Cont.)

Property	Value
Supported bandwidths	B8: 5, 10 MHz B28: 5, 10, 15, 20 MHz n8/n28: 5, 10, 15, 20 MHz
PIM cancellation	Yes

Interfaces

Figure 90 AHPDA interfaces

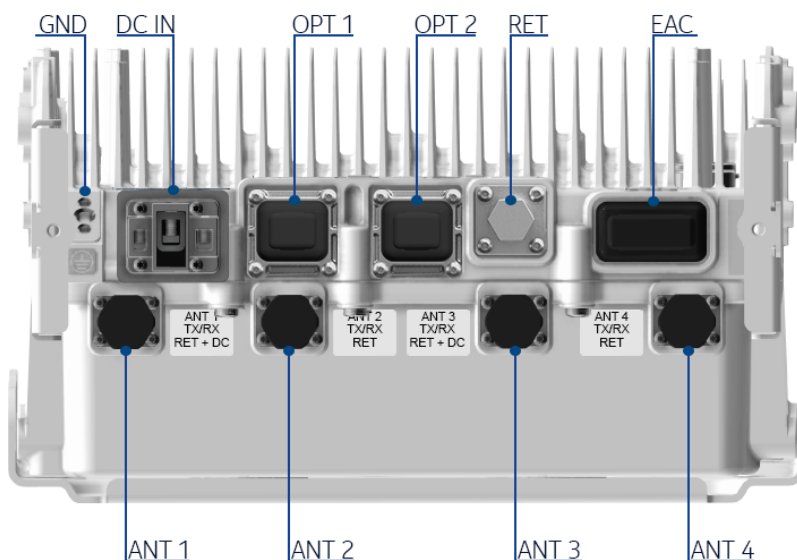



Table 340 AHPDA interfaces

Interface	Label on the HW	Number of interfaces	Connector type	Additional info
Power connector	DC IN	1	Terminal block	Max wire gauge 4 AWG with max strand diameter 7 mm (max 105 strands)
Antenna connector	ANT	4	4.3-10+	AISG on all ports and BiasT support on ANT1 and ANT3; has features that prevent damage if mating with a 4.1-9.5 connector is attempted

Table 340 AHPDA interfaces (Cont.)

Interface	Label on the HW	Number of interfaces	Connector type	Additional info
Remote electrical tilt	RET	1	8-pin circular	AISG RS485
External alarm connection	EAC	1	MDR-26	4 inputs and 1 control output
Optical interface	OPT	2	SFP+	9.8 Gbps, CPRI; Nokia IP seal
Grounding		1	M8 or dual M5 screws	-
Fan	FAN	1	Nokia fan	Located on the heat sink side



WARNING! Risk of electric shock

Before turning RF power on, RF ports have to be terminated by nominal 50 Ω load (for example, feeder with antenna). However, if these conditions are not met, the plastic caps that are delivered within the unused RF ports should remain in place. The plastic caps isolate RF port from the environment, and thus provide electric shock security in case RF power is accidentally on.

Antenna Line Devices (ALDs) support

Table 341 AHPDA ALD support

Property	Value
AISG	2.0
CWA (for non-AISG installations)	No
Voltage	14.5 V (ANT1 and ANT3 only)
Power per port	30 W, 45 W total

Functional block diagram

Figure 91 AHPDA functional block diagram

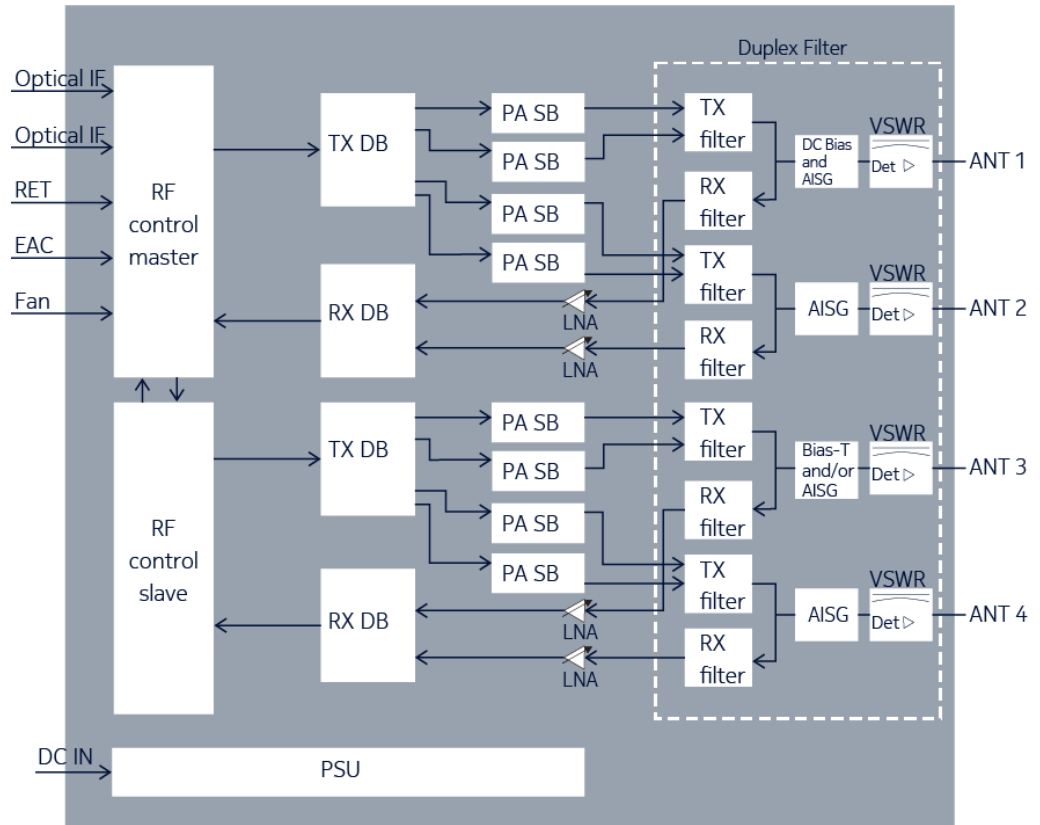

Electrical specifications

Table 342 AHPDA electrical specifications

Property	Value
Nominal supply voltage	-48.0 V DC
Nominal input voltage range	-40.5 V DC to -57.0 V DC
Extended input voltage range	-36.0 V DC to -40.5 V DC -57.0 V DC to -60.0 V DC

Note: The minimum start-up voltage is -40.5 V DC. If the input voltage is below/beyond the extended limits, the unit might shut down.

Power consumption

Note: AHPDA power consumption will be provided in future releases.

Power reduction

Note: Note: The maximum power reduction (dlCellPwrRed) value is 20 dB. High power reduction values may cause radio outages.

Related optional items

- FPKA Flexi Pole Mounting Kit (471649A)
- FPKC Flexi Pole Mounting Kit (472821A)
- AMFD AirScale 2 FPKx Fixing Adapter 600 (474293A)
- ASAA AirScale 2 MDR26-open EAC cable (474288A)
- ACPB AirScale 2 Fiber connector R2CT (474384A)

Installation options

- Pole
- Wall

Dimensions and weight

Table 343 AHPDA dimensions and weight

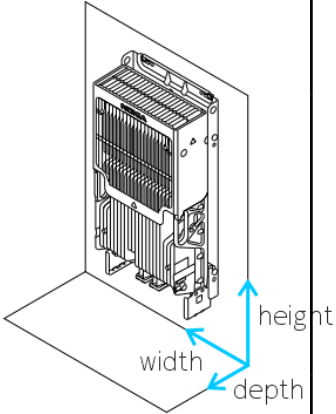
Property	Value	Dimensions orientation
Height	694 mm (27.32 in.) With mounting cover and bracket: 730 mm (28.74 in.)	
Width	308 mm (12.13 in.) With mounting bracket: 327 mm (12.87 in.)	
Depth	171 mm (6.73 in.) With mounting cover and bracket: 182 mm (7.17 in.)	
Weight	44 kg (97.0 lb)	

Environmental specifications

Table 344 AHPDA environmental specifications

Property	Value
Maximum operational outdoor temperature (in the shade)	55°C (131°F)
Maximum operational outdoor temperature (in the sun)	50°C (122°F)
Maximum indoor temperature	45°C (113°F)
Minimum operational temperature	-40°C (-40°F)
IP rating	IP65

SR002869 feature interdependencies

The SR002869: MSR support for AirScale Dual RRH 4T4R B8/28 480 W AHPDA feature is impacted by the following features:

- LTE112: Cell Bandwidth - 20 MHz needs to be enabled to use LTE 20 MHz carriers.

- *LTE113: Cell Bandwidth - 15 MHz* needs to be enabled to use LTE 15 MHz carriers.
- *LTE114: Cell Bandwidth - 10 MHz* needs to be enabled to use LTE 10 MHz carriers.
- *LTE115: Cell Bandwidth - 5 MHz* needs to be enabled to use LTE 5 MHz carriers.
- With *LTE614: Distributed Site*, AHPDA can be used in distributed sites with up to 23 km (14.29 mi) fiber length to the system module.
- With *LTE1434: Flexi Multiradio BTS antenna Rx RF-sniffing* AHPDA supports rx-sniffing.
- With *LTE2541: Nokia CPRI RRH/RFM chaining* AHPDA supports Nokia CPRI chain of up to four radio units.
- With *LTE2556: Flexi Multiradio BTS Rx-Sniffing enhancements* AHPDA supports rx-sniffing.
- Power saving features:
 - *LTE1103: Load based Power Saving for multi-layer networks*
 - *LTE1203: Load based Power Saving with Tx path switching off*
 - *LTE2508: BTS Embedded Power Meter for Energy Efficiency Monitoring*
 - *LTE3036: Micro DTX extension*

5.3.11 Nokia AirScale Dual RRH 4T4R B12/14 320 W (AHLBA)

AHLBA is introduced by LTE3847: Nokia AirScale Dual RRH 4T4R B12/14 320 W (AHLBA).

Functional description

Table 345 AHLBA functional specification

Property	Value
Output power	4x80 W (can be shared between the bands)
QAM	256 QAM (DL) 64 QAM (UL)
Number of TXRX	B12: 4T4R B14: 4T4R
Outdoor installation	Yes
Supported technologies (standalone and MSR)	FDD-LTE, 5G-ready
TX frequency range	B12: 729 - 745 MHz B14: 758 - 768 MHz
RX frequency range	B12: 699 - 715 MHz B14: 788 - 798 MHz
DL filter bandwidth	B12: 16 MHz B14: 10 MHz

Table 345 AHLBA functional specification (Cont.)

Property	Value
UL filter bandwidth	B12: 16 MHz B14: 10 MHz
DL instantaneous bandwidth	B12: 16 MHz B14: 10 MHz
UL instantaneous bandwidth	B12: 16 MHz B14: 10 MHz
DL occupied bandwidth	B12: 16 MHz B14: 10 MHz
UL occupied bandwidth	B12: 16 MHz B14: 10 MHz
Number of carriers per pipe	Up to 3
Supported bandwidths	LTE: 5, 10 MHz
PIM cancellation	Yes

Interfaces

Figure 92 AHLBA interfaces

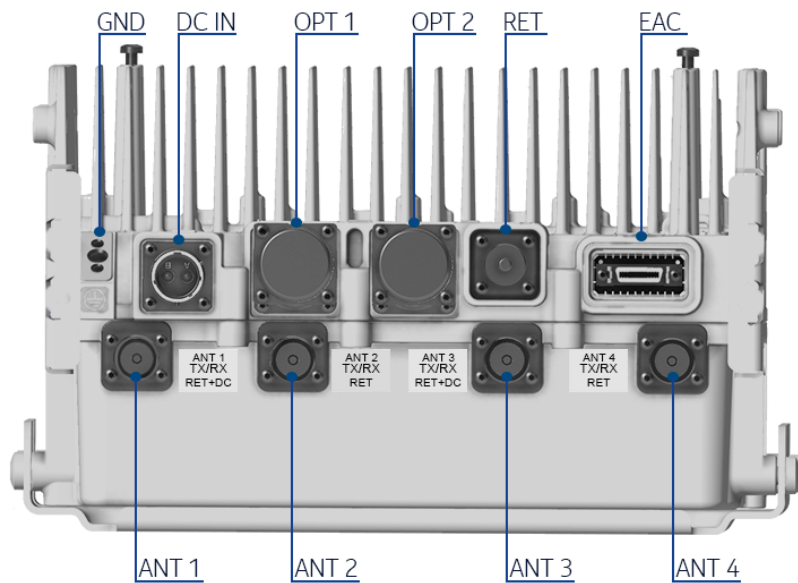

Table 346 AHLBA interfaces

Interface	Label on the HW	Number of interfaces	Connector type	Additional info
Power Connector	DC IN	1	High power circular	APPB, APPC
Antenna connector	ANT	4	4.3-10	AISG on all ports, BiasT support on ANT1 and ANT3 Has features that prevent damage if mating with a 4.1-9.5 connector is attempted
Remote Electrical Tilt	RET	1	8-pin circular	RS-485
External Alarm Connection	EAC	1	MDR-26	4 alarm inputs and 1 control output
Optical interface	OPT	2	SFP+ (R2CT)	9.8 Gbps, CPRI; R2CT IP seal
Grounding		1	M8 or dual M5 screws	-
Fan	FAN	1	Nokia fan	Located on the heat sink side

**WARNING! Risk of electric shock**

Before turning RF power on, RF ports have to be terminated by nominal 50 Ω load (for example, feeder with antenna). However, if these conditions are not met, the plastic caps that are delivered within the unused RF ports should remain in place. The plastic caps isolate RF port from the environment, and thus provide electric shock security in case RF power is accidentally on.

Antenna Line Devices (ALDs) support

Table 347 AHLBA ALD support

ALD support	Value
AISG	2.0, 3.0
CWA (for non-AISG installations)	No
Voltage	14.5 V (ANT1 and ANT3 only)
Power per port	30 W, 45 W total

Functional block diagram

Figure 93 AHLBA functional block diagram

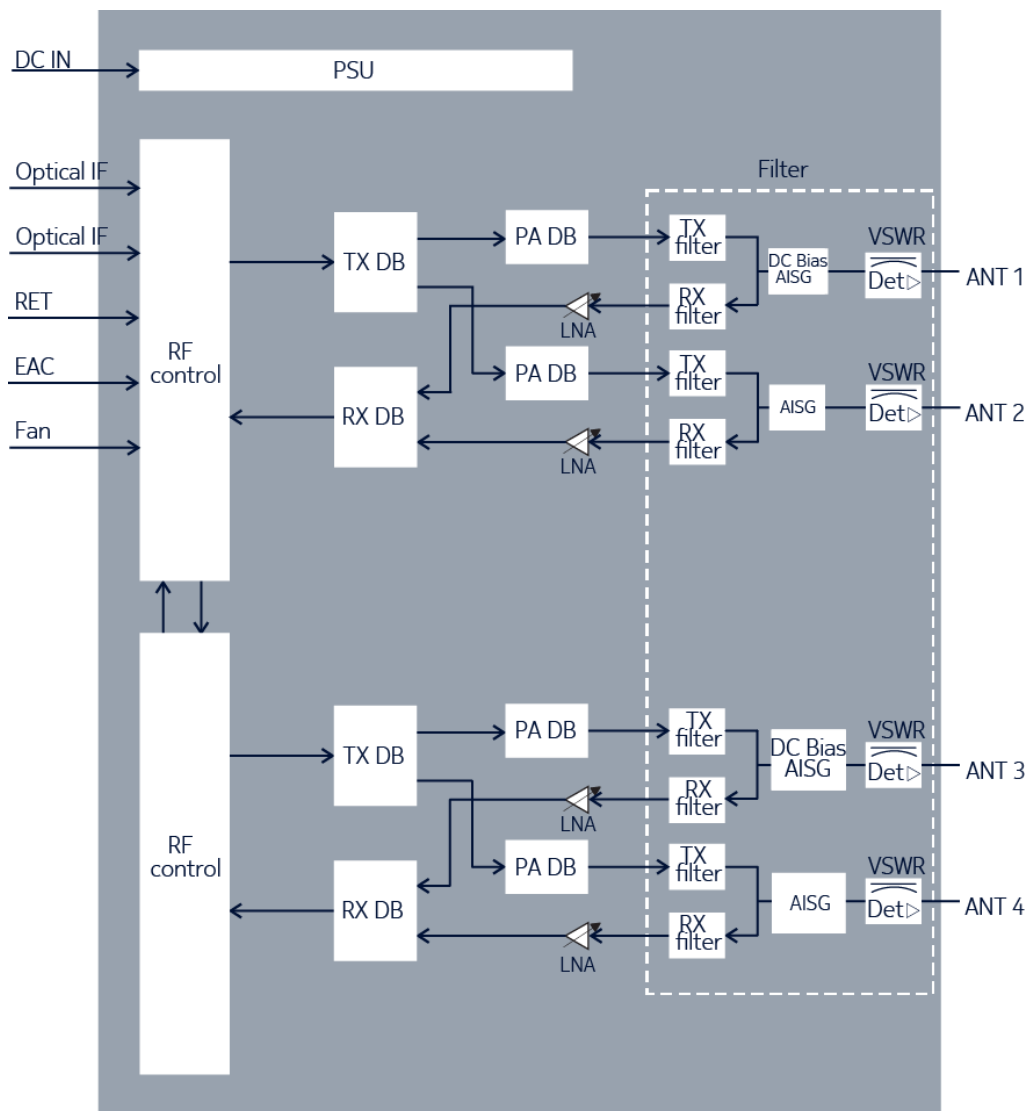

Electrical specifications

Table 348 AHLBA electrical specifications

Property	Value
Nominal supply voltage	-48.0 V DC
Nominal input voltage range	-40.5 V DC to -57.0 V DC
Extended input voltage range	-36.0 V DC to -40.5 V DC -57.0 V DC to -60.0 V DC



Note: The minimum start-up voltage is -40.5 V DC. If the input voltage is below/beyond the extended limits, the unit might shut down.

Power consumption

Typical power consumption [W] for 48VDC input, at 25°C, representative of typical product performance under the same conditions (HW variant, SW version, configuration, environment, and so on) with +/- 10% margin. Average = (6h low hour load, 10h medium hour load and 8h busy hour load) / 24h

Configurations explained on examples:

- GSM/WCDMA: 2/2/2 = three sectors, two carriers/TRXs per sector
- LTE:
 - o 2/2/2 2Tx = three sectors, two carriers per sector, 2Tx per carrier
 - o 1+1/1+1/1+1 4Tx = three dual-band sectors, one carrier per sector per band, 4Tx per carrier

Some radio units are capable of providing only one sector coverage. Then the power values in the table consider deployment of three radio units.

Table 349 AHLBA power consumption in LTE mode

Configuration	Output power per carrier [W]	Power consumption ETSI 202706 average P_{RRH} , static	Power consumption ETSI 202706 busy hour load $P_{BH\ RRH}$, static	Power consumption 100% RF power load $P_{100\% \ RRH}$
Single band 1/1/1 4Tx	4x80	1743	2138	3110
Single band 1/1/1 4Tx	4x60	1593	1892	2663
Single band 1/1/1 4Tx	4x40	1426	1627	2128
Single band 1/1/1 2Tx	2x80	1169	1376	1881
Single band 1/1/1 2Tx	2x60	1087	1244	1637
Single band 1/1/1 2Tx	2x40	998	1098	1347
Dual band 1+1 / 1+1 / 1+1 4Tx	4x40	1830	2264	3219
Dual band 1+1 / 1+1 / 1+1 4Tx	4x30	1659	1995	2761
Dual band 1+1 / 1+1 / 1+1 4Tx	4x20	1477	1706	2216
Dual band 1+1 / 1+1 / 1+1 2Tx	2x40	1208	1432	1918
Dual band 1+1 / 1+1 / 1+1 2Tx	2x30	1119	1287	1665
Dual band 1+1 / 1+1 / 1+1 2Tx	2x20	1023	1137	1386

Power reduction

Table 350 Recommended AHLBA power reduction in 256 QAM (carrier spacing over 100 MHz)

Single carrier [dB]	Dual carrier [dB]	Triple carrier [dB]	Quad carrier [dB]
0	0	0	0



Note: The maximum power reduction (`dlCellPwrRed`) value is 20 dB. High power reduction values may cause radio outages.

Related optional items

- ASFC AirScale 2 fan unit 600 (474484A)
- AMBH AirScale book mount kit 176-200 (474280A)
- FPKA Flexi Pole Mounting Kit (30-120 mm) (471649A)
- FPKC Flexi Pole Mounting Kit (60-300 mm) (472821A)
- AMPA Pole Mounting Kit (30-120 mm) (473879A)
- AMFD AirScale 2 FPKx Fixing Adapter 600 (474293A)
- ASAA AirScale 2 MDR26-open EAC cable 5 m (474288A)
- APPB AirScale 2 55A DC plug 3.3-10 mm² (474282A)
- APPC AirScale 2 55A DC plug 10-16 mm² (474283A)
- ACPB AirScale 2 Fiber connector R2CT V2 (474384A)
- AMRB AirScale one clip bracket 126-200 (474581A)
- AMRC AirScale one clip rail 600 mm (474583A)

Installation options

- Wall installation
- Pole installation
- Vertical book mount
- Horizontal book mount (fan is required)
- One-clip rail installation



NOTICE: Install this RRH in a vertical orientation with connectors on the bottom side, to ensure convection cooling. For horizontal installation fans are required.

Dimensions and weight

Table 351 AHLBA dimensions and weight

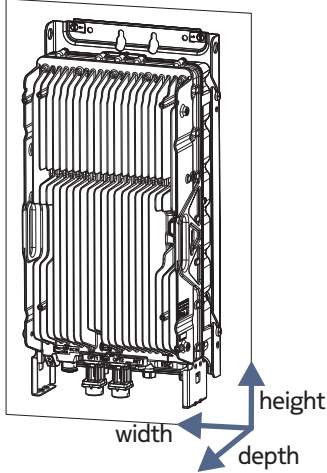
Property	Value	Dimensions orientation
Height	Core RRH: 560 mm (22.0 in.) With upper and lower mounting brackets: 675 mm (26.6 in.)	
Width	Core RRH: 308 mm (12.1 in.) With mounting brackets: 327 mm (12.9 in.)	
Depth	Core RRH: 177 mm (7.0 in.) With mounting brackets: 193 mm (7.6 in.)	
Weight	35 kg (77.2 lb)	

Environmental specifications

Table 352 AHLBA environmental specifications

Property	Value
Maximum operational outdoor temperature (in the shade) with fan or 10.8 km/h (6.7 mph) wind	55°C (131°F)
Maximum operational outdoor temperature (in the sun) with fan or 10.8 km/h (6.7 mph) wind	50°C (122°F)
Maximum indoor temperature	45°C (113°F)
Minimum operational temperature	-40°C (-40°F)
IP rating	IP65

LTE3847 impact on other features

The *LTE3847: Nokia AirScale Dual RRH 4T4R B12/14 320 W* feature is impacted by the following features:

- *LTE114: Cell Bandwidth - 10 MHz* needs to be enabled to use LTE 10 MHz carriers.
- *LTE115: Cell Bandwidth - 5 MHz* needs to be enabled to use LTE 5 MHz carriers.
- With *LTE614: Distributed Site*, AHLBA can be used in distributed sites with up to 23 km fiber length to the system module.
- *LTE1103: Load based Power Saving for multi-layer networks* needs to be enabled to use Load based Power Saving for multi-layer networks.
- *LTE1203: Load based Power Saving with Tx path switching off* needs to be enabled to use Load based Power Saving with Tx path switching off.
- *LTE2508: BTS Embedded Power Meter for Energy Efficiency Monitoring*

needs to be enabled to use BTS Embedded Power Meter for Energy Efficiency Monitoring.

- With *LTE2541: Nokia CPRI RRH/RFM chaining*, AHLBA supports Nokia CPRI chain of up to four radio units.
- *LTE2863: PIM Cancellation for AirScale 2.0 Radios* needs to be enabled to activate PIM cancellation feature (licenced feature).
- *LTE3036: Micro DTX extension* needs to be enabled to use Micro DTX extension.

5.3.12 Nokia AirScale Dual RRH 4T4R B12/71 240 W (AHLOA)

AHLOA is introduced by LTE3899: Nokia AirScale Dual RRH 4T4R B12/71 240 W (AHLOA).

Functional description

Table 353 AHLOA functional specification

Property	Value
Output power	4x60 W (can be shared between the bands)
QAM	256 QAM (DL) 64 QAM (UL)
Number of TXRX	B71: 4T4R B12, B17: 4T4R NB-IoT B85: 4T4R
Outdoor installation	Yes
Supported technologies (standalone and MSR)	FDD-LTE, 5G-ready
IoT support	B85: NB-IoT in band, guard band (GB), standalone (SA)
TX frequency range	B71: 617 - 652 MHz B12 + B85: 728 - 746 MHz
RX frequency range	B71: 663 - 698 MHz B12 + B85: 698 - 716 MHz
DL filter bandwidth	B71: 35 MHz B12 + B85: 18 MHz
UL filter bandwidth	B71: 35 MHz B12 + B85: 18 MHz
iBW (instantaneous bandwidth)	B71: 35 MHz B12 + B85: 18 MHz
oBW (occupied bandwidth)	B71: 35 MHz

Table 353 AHLOA functional specification (Cont.)

Property	Value
	B12 + B85: 18 MHz
Supported bandwidths	LTE: 1.4, 3, 5, 10, 15, 20 MHz NB-IoT: 1 MHz
PIM cancellation	Yes

Interfaces

Figure 94 AHLOA interfaces (Style A)

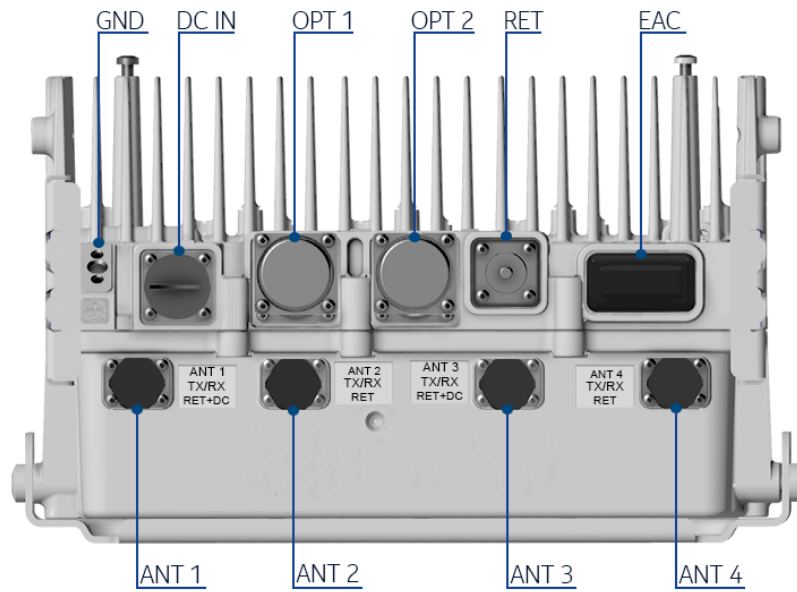

Figure 95 AHLOA interfaces (Style B)

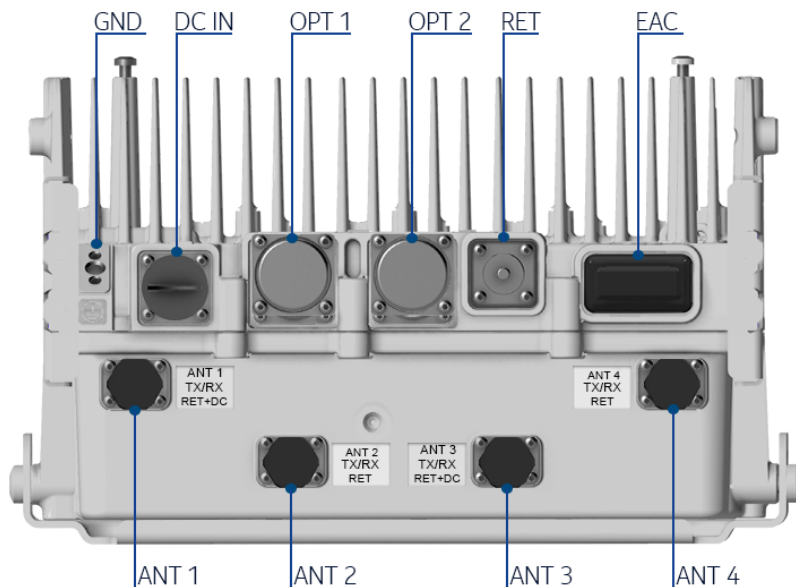



Table 354 AHLOA interfaces

Interface	Label on the HW	Number of interfaces	Connector type	Additional info
Power Connector	DC IN	1	High power circular	APPB, APPC
Antenna connector	ANT	4	4.3-10	AISG on all ports, BiasT support on ANT1 & ANT3 Has features that prevent damage if mating with a 4.1-9.5 connector is attempted
Remote Electrical Tilt	RET	1	8-pin circular	RS-485
External Alarm Connection	EAC	1	MDR-26	4 alarm inputs and 1 control output
Optical interface	OPT	2	SFP+ (R2CT)	9.8 Gbps, CPRI; R2CT IP seal
Grounding		1	M8 or dual M5 screws	-
Fan	FAN	1	Nokia fan	Located on the heat sink side

**WARNING! Risk of electric shock**

Before turning RF power on, RF ports have to be terminated by nominal 50 Ω load (for example, feeder with antenna). However, if these conditions are not met, the plastic caps that are delivered within the unused RF ports should remain in place. The plastic caps isolate RF port from the environment, and thus provide electric shock security in case RF power is accidentally on.

Antenna Line Devices (ALDs) support

Table 355 AHLOA ALD support

ALD support	Value
AISG	2.0, 3.0
CWA (for non-AISG installations)	No
Voltage	14.5 V (ANT1 and ANT3 only)
Power per port	30 W, 45 W total

Functional block diagram

Figure 96 AHLOA functional block diagram

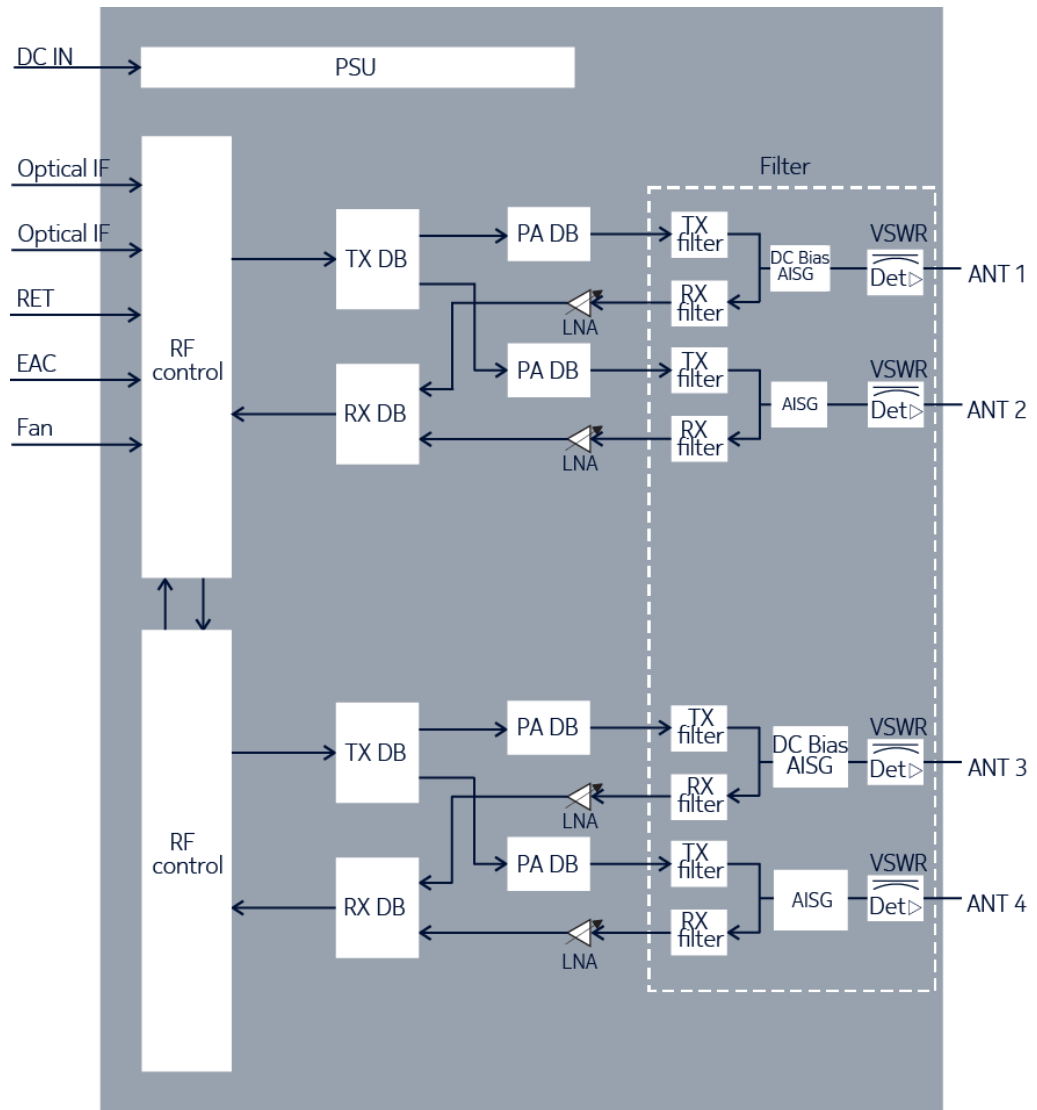

Electrical specifications

Table 356 AHLOA electrical specifications

Property	Value
Nominal supply voltage	-48.0 V DC
Nominal input voltage range	-40.5 V DC to -57.0 V DC
Extended input voltage range	-36.0 V DC to -40.5 V DC -57.0 V DC to -60.0 V DC



Note: The minimum start-up voltage is -40.5 V DC. If the input voltage is below/beyond the extended limits, the unit might shut down.

Power consumption



Note: AHLOA power consumption will be provided in future releases.

Power reduction

Table 357 Recommended AHLOA power reduction in 256 QAM (carrier spacing over 100 MHz)

Single carrier [dB]	Dual carrier [dB]	Triple carrier [dB]	Quad carrier [dB]
0	0.8	0.8	0.8



Note: The maximum power reduction (`dlCellPwrRed`) value is 20 dB. High power reduction values may cause radio outages.

Related optional items

- ASFC AirScale 2 fan unit 600 (474484A)
- AMBH AirScale book mount kit 176-200 (474280A)
- FPKA Flexi Pole Mounting Kit (30-120 mm) (471649A)
- FPKC Flexi Pole Mounting Kit (60-300 mm) (472821A)
- APAF AirScale AC-DC PSU 208-240VAC/1150W (474676A)
- AMPA Pole Mounting Kit (30-120 mm) (473879A)
- AMFD AirScale 2 FPKx Fixing Adapter 600 (474293A)
- ASAA AirScale 2 MDR26-open EAC cable 5 m (474288A)
- APPB AirScale 2 55A DC plug 3.3-10 mm² (474282A)
- APPC AirScale 2 55A DC plug 10-16 mm² (474283A)
- ACPB AirScale 2 Fiber connector R2CT V2 (474384A)
- AMRC AirScale one clip rail 600 mm (474583A)
- AMRD AirScale one clip bracket over 200 (474582A)

Installation options

- Wall installation
- Pole installation
- Vertical book mount
- Horizontal book mount (fan is required)
- One-clip rail installation



NOTICE: Install this RRH in a vertical orientation with connectors on the bottom side, to ensure convection cooling. For horizontal installation fans are required.

Dimensions and weight

Table 358 AHLOA dimensions and weight

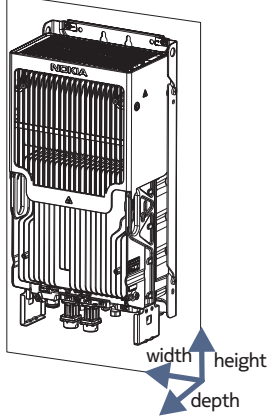
Property	Value	Dimensions orientation
Height	Core RRH: 560 mm (22.0 in.) With upper and lower mounting brackets: 675 mm (26.6 in.)	
Width	Core RRH: 308 mm (12.1 in.) With mounting brackets: 327 mm (12.9 in.)	
Depth	Core RRH: 189 mm (7.4 in.) With mounting brackets: 205 mm (8.1 in.)	
Weight	38 kg (83.8 lb)	

Environmental specifications

Table 359 AHLOA environmental specifications

Property	Value
Maximum operational outdoor temperature (in the shade) with fan or 10.8 km/h (6.7 mph) wind	55°C (131°F)
Maximum operational outdoor temperature (in the sun) with fan or 10.8 km/h (6.7 mph) wind	50°C (122°F)
Maximum indoor temperature	45°C (113°F)
Minimum operational temperature	-40°C (-40°F)
IP rating	IP65

LTE3899 impact on other features

The *LTE3899: Nokia AirScale Dual RRH 4T4R B12/71 240 W* feature is impacted by the following features:

- *LTE112: Cell Bandwidth - 20 MHz* needs to be enabled to use LTE 20 MHz carriers.
- *LTE113: Cell Bandwidth - 15 MHz* needs to be enabled to use LTE 15 MHz carriers.
- *LTE114: Cell Bandwidth - 10 MHz* needs to be enabled to use LTE 10 MHz carriers.
- *LTE115: Cell Bandwidth - 5 MHz* needs to be enabled to use LTE 5 MHz carriers.
- *LTE116: Cell Bandwidth - 3 MHz* needs to be enabled to use LTE 3 MHz carriers.
- *LTE117: Cell Bandwidth - 1.4 MHz* needs to be enabled to use LTE 1.4 MHz carriers.
- With *LTE614: Distributed Site*

AHLOA can be used in distributed sites with up to 23 km fiber length to the system module.

- *LTE1103: Load based Power Saving for multi-layer networks* needs to be enabled to use Load based Power Saving for multi-layer networks.
- *LTE1203: Load based Power Saving with Tx path switching off* needs to be enabled to use Load based Power Saving with Tx path switching off.
- *LTE2508: BTS Embedded Power Meter for Energy Efficiency Monitoring* needs to be enabled to use BTS Embedded Power Meter for Energy Efficiency Monitoring.
- With *LTE2541: Nokia CPRI RRH/RFM chaining*, AHLOA supports Nokia CPRI chain of up to four radio units.
- *LTE3036: Micro DTX extension* needs to be enabled to use Micro DTX extension.

5.3.13 Nokia AirScale Dual RRH 4T4R B13/71 (n71) 240 W (AHBOA)

AHBOA is introduced by LTE4988, SR002582, 5GC002424: Nokia AirScale Dual RRH 4T4R B13/71 (n71) 240 W (AHBOA).

Functional description

Table 360 AHBOA functional specification

Property	Value
Output power	4x60 W
QAM	256 QAM (DL) 64 QAM (UL)
Number of TXRX	4T4R
Outdoor installation	Yes
Supported technologies (standalone and MSR)	FDD-LTE, 5G
TX frequency range	B13: 746–756 MHz B71/n71: 617–652 MHz
RX frequency range	B13: 777–787 MHz B71/n71: 663–698 MHz
DL filter bandwidth	B13: 10 MHz B71/n71: 35 MHz
UL filter bandwidth	B13: 10 MHz B71/n71: 35 MHz
iBW (instantaneous bandwidth)	B13: 10 MHz B71/n71: 35 MHz

Table 360 AHBOA functional specification (Cont.)

Property	Value
oBW (occupied bandwidth)	B13: 10 MHz B71/n71: 35 MHz
Number of carriers per pipe	B13: up to 2 B71/n71: up to 4 carriers in total for all supported RATs
Supported bandwidths	B13 (LTE only): 5, 10 MHz B71/n71 (LTE and 5G): 5, 10, 15, 20 MHz
PIM cancellation	Yes

Interfaces

Figure 97 AHBOA interfaces

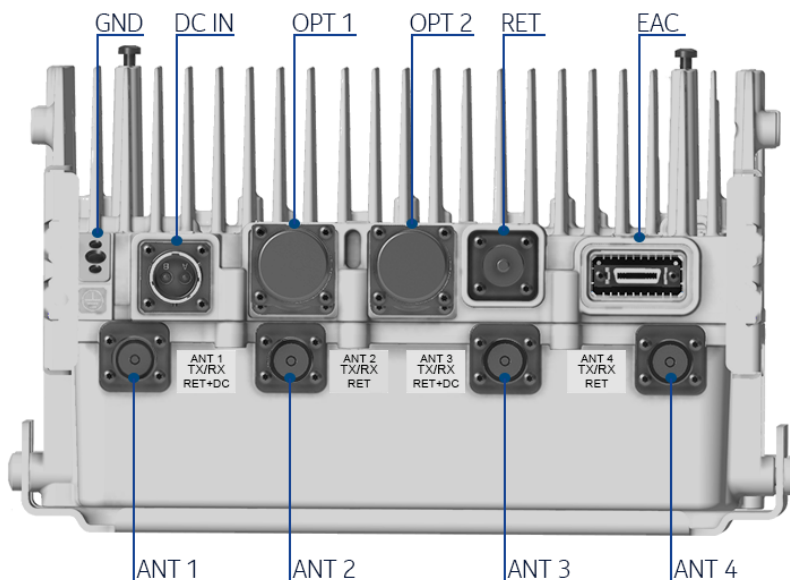



Table 361 AHBOA interfaces

Interface	Label on the HW	Number of interfaces	Connector type	Additional info
Power Connector	DC IN	1	High power circular	APPB, APPC
Antenna connector	ANT	4	4.3-10+	AISG on all ports, BiasT support on ANT1 and ANT3; has features that prevent damage if mating with a 4.1-

Table 361 AHBOA interfaces (Cont.)

Interface	Label on the HW	Number of interfaces	Connector type	Additional info
				9.5 connector is attempted
Remote Electrical Tilt	RET	1	8-pin circular	RS-485
External Alarm Connection	EAC	1	MDR-26	4 inputs and 1 control output
Optical interface	OPT	2	SFP+ (R2CT)	9.8 Gbps, CPRI; R2CT IP seal
Grounding		1	M8 or dual M5 screws	-
Fan	FAN	1	Nokia fan	Located on the heat sink side

**WARNING! Risk of electric shock**

Before turning RF power on, RF ports have to be terminated by nominal 50 Ω load (for example, feeder with antenna). However, if these conditions are not met, the plastic caps that are delivered within the unused RF ports should remain in place. The plastic caps isolate RF port from the environment, and thus provide electric shock security in case RF power is accidentally on.

Antenna Line Devices (ALDs) support

Table 362 AHBOA ALD support

Property	Value
AISG	2.0, 3.0
CWA (for non-AISG installations)	No
Voltage	14.5 V (ANT1 and ANT3 only)
Power per port	30 W, 45 W total

Functional block diagram

Figure 98 AHBOA functional block diagram

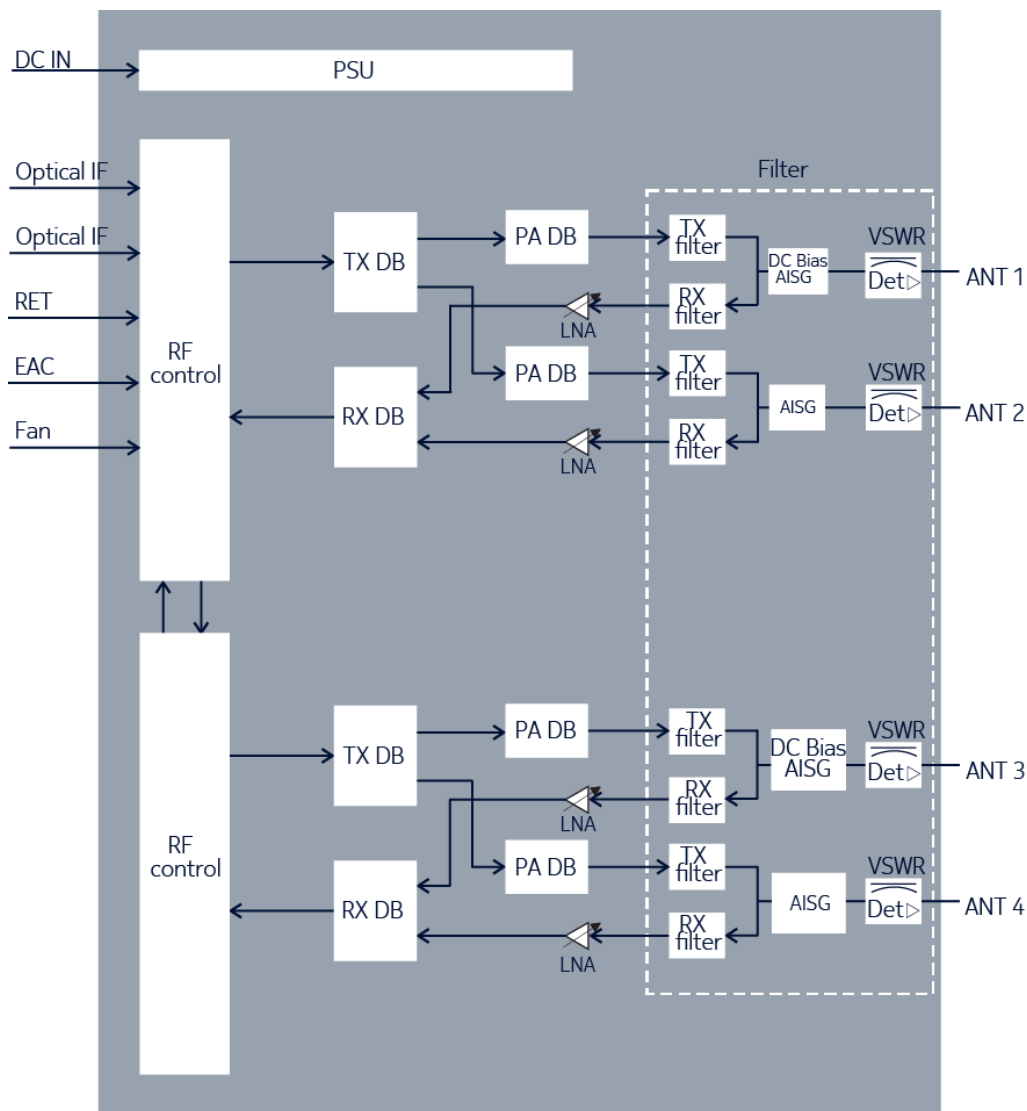

Electrical specifications

Table 363 AHBOA electrical specifications

Property	Value
Nominal supply voltage	-48.0 V DC
Nominal input voltage range	-40.5 V DC to -57.0 V DC
Extended input voltage range	-36.0 V DC to -40.5 V DC -57.0 V DC to -60.0 V DC



Note: The minimum start-up voltage is -40.5 V DC. If the input voltage is below/beyond the extended limits, the unit might shut down.

Power consumption



Note: AHBOA power consumption will be provided in future releases.

Power reduction

Table 364 Recommended AHBOA power reduction in 256 QAM

Single carrier [dB]	Dual carrier [dB]	Triple carrier [dB]	Quad carrier [dB]
0	0.8	0.8	0.8



Note: The maximum power reduction (`dlCellPwrRed`) value is 20 dB. High power reduction values may cause radio outages.

Related optional items

- ASFC AirScale 2 fan unit 600 (474484A)
- AMBH AirScale book mount kit 176-200 (474280A)
- FPKA Flexi Pole Mounting Kit (30-120 mm) (471649A)
- FPKC Flexi Pole Mounting Kit (60-300 mm) (472821A)
- APAF AirScale AC-DC PSU 208-240VAC/1150W (474676A)
- AMPA Pole Mounting Kit (30-120 mm) (473879A)
- AMFD AirScale 2 FPKx Fixing Adapter 600 (474293A)
- ASAA AirScale 2 MDR26-open EAC cable 5 m (474288A)
- APPB AirScale 2 55A DC plug 3.3-10 mm² (474282A)
- APPC AirScale 2 55A DC plug 10-16 mm² (474283A)
- ACPB AirScale 2 Fiber connector R2CT V2 (474384A)
- AMRC AirScale one clip rail 600 mm (474583A)
- AMRD AirScale one clip bracket over 200 (474582A)

Installation options

- Wall installation
- Pole installation
- Vertical book mount
- Horizontal book mount
- One-clip rail mounting



NOTICE: Install this RRH in a vertical orientation with connectors on the bottom side, to ensure convection cooling. For horizontal installation fans are required.

Dimensions and weight

Table 365 AHBOA dimensions and weight

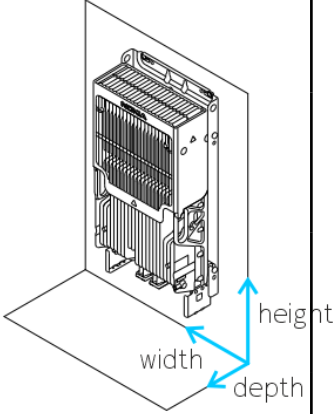
Property	Value	Dimensions orientation
Height	Core RRH: 560 mm (22.04 in.) With upper and lower mounting brackets: 675 mm (26.57 in.)	
Width	Core RRH: 308 mm (12.13 in.) With mounting brackets: 327 mm (12.87 in.)	
Depth	Core RRH: 189 mm (7.44 in.) With mounting brackets: 205 mm (8.07 in.)	
Weight	Core RRH: 38 kg (83.8 lb)	
Volume	Core RRH: 33 l	

Environmental specifications

Table 366 AHBOA environmental specifications

Property	Value
Maximum operational outdoor temperature (in the shade) with fan or 10.8 km/h (6.7 mph) wind	55°C (131°F)
Maximum operational outdoor temperature (in the sun) with fan or 10.8 km/h (6.7 mph) wind	50°C (122°F)
Maximum indoor temperature	45°C (113°F)
Minimum operational temperature	-40°C (-40°F)
IP rating	IP65

LTE4988 feature interdependencies

The *LTE4988: Nokia AirScale Dual RRH 4T4R B13/71 240 W (AHBOA)* feature is impacted by the following features:

- *LTE112: Cell Bandwidth - 20 MHz* needs to be enabled to use LTE 20 MHz carriers.
- *LTE113: Cell Bandwidth - 15 MHz* needs to be enabled to use LTE 15 MHz carriers.
- *LTE114: Cell Bandwidth - 10 MHz* needs to be enabled to use LTE 10 MHz carriers.
- *LTE115: Cell Bandwidth - 5 MHz* needs to be enabled to use LTE 5 MHz carriers.
- With *LTE614: Distributed Site*, AHBOA can be used in distributed sites with up to 23 km fiber length to the system module.
- *LTE1103: Load based Power Saving for multi-layer networks* works when enabled in the settings.

- *LTE1203: Load based Power Saving with Tx path switching off* works when enabled in the settings.
- *LTE2508: BTS Embedded Power Meter for Energy Efficiency Monitoring* works when enabled in the settings.
- With *LTE2541: Nokia CPRI RRH/RFM chaining*, AHBOA supports Nokia CPRI chain of up to four radio units.
- *LTE2863: PIM Cancellation for AirScale 2.0 Radios* needs to be enabled to activate PIM cancellation feature (licenced feature).
- *LTE3036: Micro DTX extension* works when enabled in the settings.

5.3.14 Nokia AirScale Dual RRH 4T4R B25/66 320 W (AHFIB)

AHFIB is introduced by LTE3789/SR001767: Nokia AirScale Dual RRH 4T4R B25/66 320 W (AHFIB).

Functional description

Table 367 AHFIB functional specification

Property	Value
Output power	2x4x40 W
QAM	256 QAM (DL) 64 QAM (UL)
Number of TXRX	B25: 4T4R B66: 4T4R
Outdoor installation	Yes
Supported technologies (standalone and MSR)	B25: GSM, WCDMA, FDD-LTE, GSM-WCDMA-LTE, GSM-WCDMA, GSM-LTE, WCDMA-LTE B66a: WCDMA, FDD-LTE, WCDMA-LTE 5G-ready
TX frequency range	B25: 1930 MHz – 1995 MHz B66: 2110 MHz – 2200 MHz
RX frequency range	B25: 1850 MHz – 1915 MHz B66: 1710 MHz – 1780 MHz
DL filter bandwidth	B25: 65 MHz B66: 90 MHz
UL filter bandwidth	B25: 65 MHz B66: 70 MHz
DL iBW (instantaneous bandwidth)	B25: 65 MHz

Table 367 AHFIB functional specification (Cont.)

Property	Value
	B66: 90 MHz
UL iBW (instantaneous bandwidth)	B25: 65 MHz B66: 70 MHz
DL oBW	B25: 65 MHz B66: 80 MHz
UL oBW	B25: 65 MHz B66: 70 MHz
Number of carriers per pipe	Up to 8
Supported bandwidths	LTE: 1.4, 3, 5, 10, 15, 20 MHz i Note: The 1.4 MHz and 3 MHz bandwidths are not supported in the upper 5 MHz of Band 25.
PIM cancellation	Yes

Interfaces

Figure 99 AHFIB interfaces

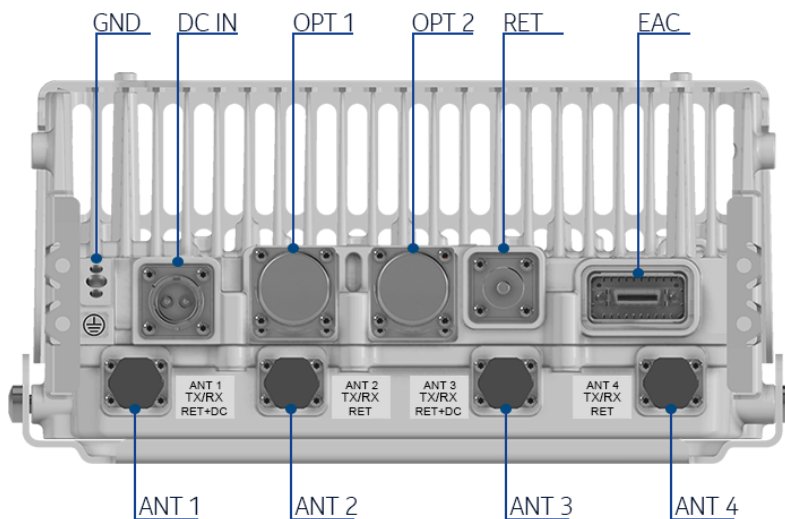



Table 368 AHFIB interfaces

Interface	Label on the HW	Number of interfaces	Connector type	Additional info
Power Connector	DC IN	1	High power circular	APPB, APPC
Antenna connector	ANT	4	4.3-10	AISG on all ports, BiasT support on ANT1 & ANT3 Has features that prevent damage if mating with a 4.1-9.5 connector is attempted
Remote Electrical Tilt	RET	1	8-pin circular	RS-485
External Alarm Connection	EAC	1	MDR-26	4 alarm inputs and 1 control output
Optical interface	OPT	2	SFP+ (R2CT)	9.8 Gbps, CPRI; R2CT IP seal
Grounding		1	M8 or dual M5 screws	-
Fan	FAN	1	Nokia fan	Located on the heat sink side



WARNING! Risk of electric shock

Before turning RF power on, RF ports have to be terminated by nominal 50 Ω load (for example, feeder with antenna). However, if these conditions are not met, the plastic caps that are delivered within the unused RF ports should remain in place. The plastic caps isolate RF port from the environment, and thus provide electric shock security in case RF power is accidentally on.

Antenna Line Devices (ALDs) support

Table 369 AHFIB ALD support

ALD support	Value
AISG	2.0, 3.0
CWA (for non-AISG installations)	No
Voltage	14.5 V (ANT1 and ANT3 only)
Power per port	30 W, 45 W total

Functional block diagram

Figure 100 AHFIB functional block diagram

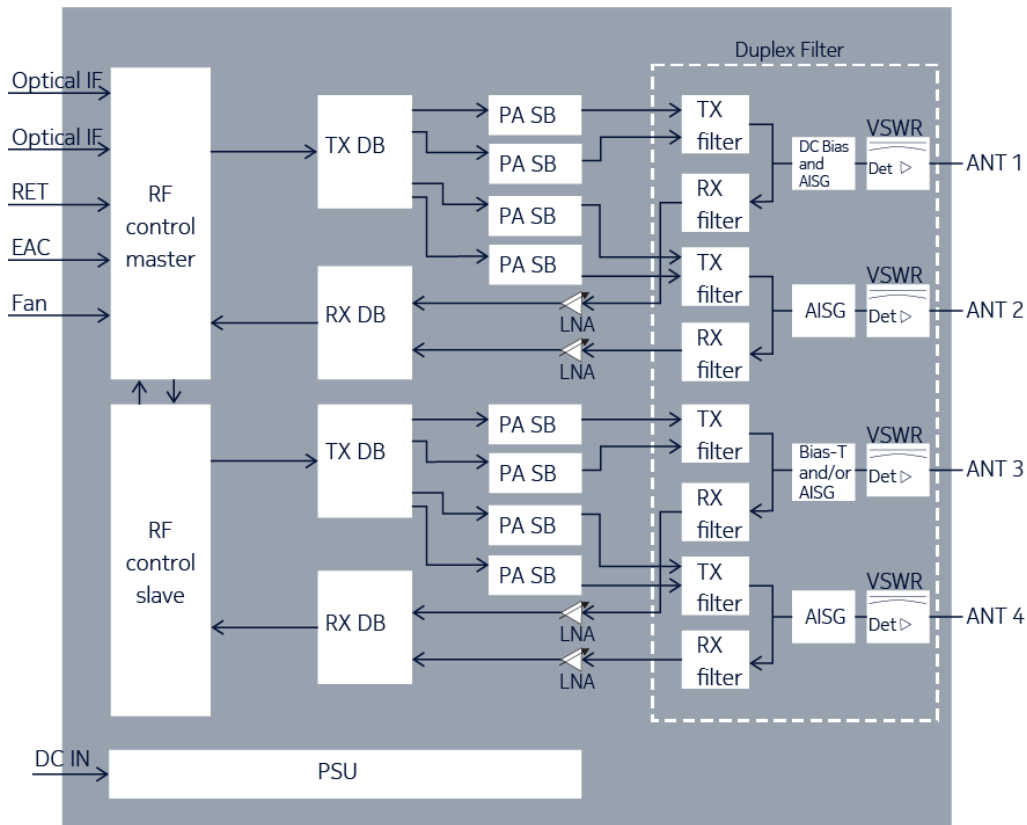

Electrical specifications

Table 370 AHFIB electrical specifications

Property	Value
Nominal supply voltage	-48.0 V DC
Nominal input voltage range	-40.5 V DC to -57.0 V DC
Extended input voltage range	-36.0 V DC to -40.5 V DC -57.0 V DC to -60.0 V DC



Note: The minimum start-up voltage is -40.5 V DC. If the input voltage is below/beyond the extended limits, the unit might shut down.

Power consumption

Typical power consumption [W] for 48VDC input, at 25°C, representative of typical product performance under the same conditions (HW variant, SW version, configuration, environment, and so on) with +/- 10% margin. Average = (6h low hour load, 10h medium hour load and 8h busy hour load) / 24h

Configurations explained on examples:

- GSM/WCDMA: 2/2/2 = three sectors, two carriers/TRXs per sector
- LTE:

- o 2/2/2 2Tx = three sectors, two carriers per sector, 2Tx per carrier
- o 1+1/1+1/1+1 4Tx = three dual-band sectors, one carrier per sector per band, 4Tx per carrier

Some radio units are capable of providing only one sector coverage. Then the power values in the table consider deployment of three radio units.

Table 371 AHFIB power consumption in LTE mode

Configuration	Output power per carrier [W]	Power consumption ETSI 202706 average P_{RRH} , static	Power consumption ETSI 202706 busy hour load $P_{BH\ RRH}$, static	Power consumption 100% RF power load $P_{100\% \ RRH}$
Single band 1/1/1 4Tx	4x40	1274	1509	2028
Single band 1/1/1 4Tx	4x20	1080	1209	1476
Single band 1/1/1 2Tx	2x40	920	1038	1305
Single band 1/1/1 2Tx	2x20	821	885	1014
Dual band 1+1/1+1/1+1 4Tx	4x40	1937	2375	3045
Dual band 1+1/1+1/1+1 4Tx	4x20	1568	1826	2336
Dual band 1+1/1+1/1+1 2Tx	2x40	1261	1503	2024
Dual band 1+1/1+1/1+1 2Tx	2x20	1064	1193	1471

Power reduction

Table 372 Recommended AHFIB power reduction per band, in 256 QAM

Single carrier [dB]	Dual carrier [dB]	Triple carrier [dB]	Quad carrier [dB]
0	0.7	0.7	0.9



Note: The maximum power reduction (`dlCellPwrRed`) value is 20 dB. High power reduction values may cause radio outages.

Related optional items

- ASFC AirScale 2 fan unit 600 (474484A)
- AMBF AirScale book mount kit 126-150 (474278A)
- FPKA Flexi Pole Mounting Kit (30-120 mm) (471649A)
- FPKC Flexi Pole Mounting Kit (60-300 mm) (472821A)
- AMPA Pole Mounting Kit (30-120 mm) (473879A)
- AMFD AirScale 2 FPKx Fixing Adapter 600 (474293A)
- ASAA AirScale 2 MDR26-open EAC cable 5 m (474288A)

- APPB AirScale 2 55A DC plug 3.3-10 mm² (474282A)
- APPC AirScale 2 55A DC plug 10-16 mm² (474283A)
- ACPB AirScale 2 Fiber connector R2CT V2 (474384A)
- AMRB AirScale one clip bracket 126-200 (474581A)
- AMRC AirScale one clip rail 600 mm (474583A)

Installation options

- Wall installation
- Pole installation
- Vertical book mount
- Horizontal book mount (fan is required)
- One-clip rail installation



NOTICE: Install this RRH in a vertical orientation with connectors on the bottom side, to ensure convection cooling. For horizontal installation fans are required.

Dimensions and weight

Table 373 AHFIB dimensions and weight

Property	Value	Dimensions orientation
Height	Core RRH: 560 mm (22.0 in.) With mounting brackets: 675 mm (26.6 in.)	
Width	Core RRH: 308 mm (12.1 in.) With mounting brackets: 327 mm (12.9 in.)	
Depth	Core RRH: 149 mm (5.9 in.) With mounting brackets: 165 mm (6.5 in.)	
Weight	30 kg (66.1 lb)	

Environmental specifications

Table 374 AHFIB environmental specifications

Property	Value
Maximum operational outdoor temperature (in the shade) with fan or 10.8 km/h (6.7 mph) wind	55°C (131°F)
Maximum operational outdoor temperature (in the sun) with fan or 10.8 km/h (6.7 mph) wind	50°C (122°F)
Maximum indoor temperature	45°C (113°F)
Minimum operational temperature	-40°C (-40°F)
IP rating	IP65

LTE3789 feature interdependencies

The *LTE3789: Nokia AirScale Dual RRH 4T4R B25/66 320 W* feature is impacted by the following features:

- *LTE112: Cell Bandwidth - 20 MHz*
needs to be enabled to use LTE 20 MHz carriers.
- *LTE113: Cell Bandwidth - 15 MHz*
needs to be enabled to use LTE 15 MHz carriers.
- *LTE114: Cell Bandwidth - 10 MHz*
needs to be enabled to use LTE 10 MHz carriers.
- *LTE115: Cell Bandwidth - 5 MHz*
needs to be enabled to use LTE 5 MHz carriers.
- *LTE116: Cell Bandwidth - 3 MHz*
needs to be enabled to use LTE 3MHz carriers.
- *LTE117: Cell Bandwidth - 1.4 MHz*
needs to be enabled to use LTE 1.4MHz carriers.
- With *LTE614: Distributed Site*,
AHFIB can be used in distributed sites with up to 23 km fiber length to the system module.
- *LTE1103: Load based Power Saving for multi-layer networks*
needs to be enabled to use Load based Power Saving for multi-layer networks.
- *LTE1203: Load based Power Saving with Tx path switching off*
needs to be enabled to use Load based Power Saving with Tx path switching off.
- *LTE2508: BTS Embedded Power Meter for Energy Efficiency Monitoring*
needs to be enabled to use BTS Embedded Power Meter for Energy Efficiency Monitoring.
- With *LTE2541: Nokia CPRI RRH/RFM chaining*,
AHFIB supports Nokia CPRI chain of up to four radio units.
- *LTE2863: PIM Cancellation for AirScale 2.0 Radios*
needs to be enabled to activate PIM cancellation feature (licenced feature).
- *LTE3036: Micro DTX extension*
needs to be enabled to use Micro DTX extension.

5.3.15 Nokia AirScale Dual RRH 4T4R B25/66 (n25/n66) 480 W (AHFIG)

AHFIG is introduced by LTE5213, SR002418, 5GC002099: Nokia AirScale Dual RRH 4T4R B25/66 (n25/n66) 480 W (AHFIG).

Functional description

Table 375 AHFIG functional specification

Property	Value
Output power	B25/n25: 4x80 W B66/n66: 4x40 W
QAM	256 QAM (DL) 64 QAM (UL)

Table 375 AHFIG functional specification (Cont.)

Property	Value
Number of TXRX	4T4R
Outdoor installation	Yes
Supported technologies (standalone and MSR)	B25: GSM, WCDMA, FDD-LTE, GSM-WCDMA, GSM-LTE, WCDMA-LTE, GSM-WCDMA-LTE B66: WCDMA (B4/B10), FDD-LTE, WCDMA-LTE n25/n66: 5G
IoT support	NB-IoT in band, guard band (GB), standalone (SA)
TX frequency range	B25/n25: 1930 MHz – 1995 MHz B66/n66: 2110 MHz – 2200 MHz
RX frequency range	B25/n25: 1850 MHz – 1915 MHz B66/n66: 1710 MHz – 1780 MHz
DL filter bandwidth	B25/n25: 65 MHz B66/n66: 80 MHz
UL filter bandwidth	B25/n25: 65 MHz B66/n66: 80 MHz
iBW (instantaneous bandwidth)	B25/n25: 65 MHz B66/n66: 80 MHz
oBW (occupied bandwidth)	B25/n25: 65 MHz B66/n66: 80 MHz
Number of carriers per pipe	Up to 8 carriers in total for all supported RATs
Supported bandwidths	LTE: 1.4, 3, 5, 10, 15, 20 MHz 5G: 5, 10, 15, 20 MHz
PIM cancellation	Yes

Interfaces

Figure 101 AHFIG interfaces

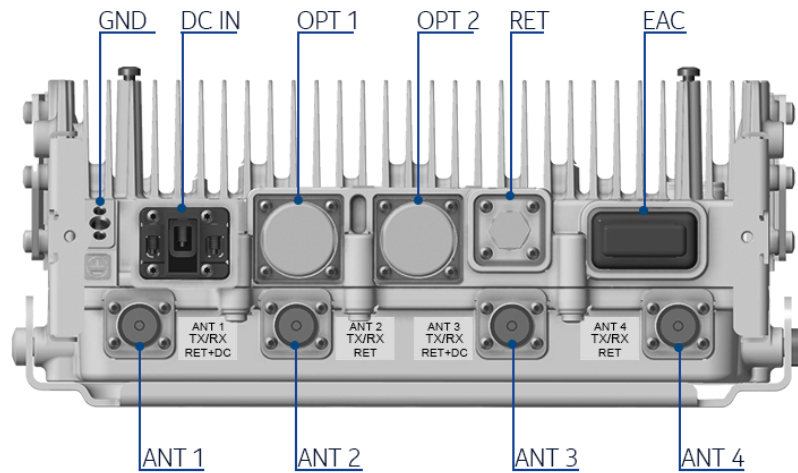



Table 376 AHFIG interfaces

Interface	Label on the HW	Number of interfaces	Connector type	Additional info
Power Connector	DC IN	1	Terminal block	Max wire gauge 4 AWG with max strand diameter 7 mm (max 105 strands)
Antenna connector	ANT	4	4.3-10+	AISG on all ports and BiasT support on ANT1 & ANT3; has features that prevent damage if mating with a 4.1-9.5 connector is attempted
Remote Electrical Tilt	RET	1	8-pin circular	AISG RS485
External Alarm Connection	EAC	1	MDR-26	4 inputs and 1 control output
Optical interface	OPT	2	SFP+ (R2CT)	9.8 Gbps, CPRI; R2CT IP seal
Grounding		1	M8 or dual M5 screws	-
Fan	FAN	1	Nokia fan	Located on the heat sink side



WARNING! Risk of electric shock

Before turning RF power on, RF ports have to be terminated by nominal 50 Ω load (for example, feeder with antenna). However, if these conditions are not met, the plastic caps that are delivered within the unused RF ports should remain in place. The plastic caps isolate RF port from the environment, and thus provide electric shock security in case RF power is accidentally on.

Antenna Line Devices (ALDs) support

Table 377 AHFIG ALD support

Property	Value
AISG	2.0, 3.0
CWA (for non-AISG installations)	No
Voltage	14.5 V (ANT1 and ANT3 only)
Power per port	30 W, 45 W total

Functional block diagram

Figure 102 AHFIG functional block diagram

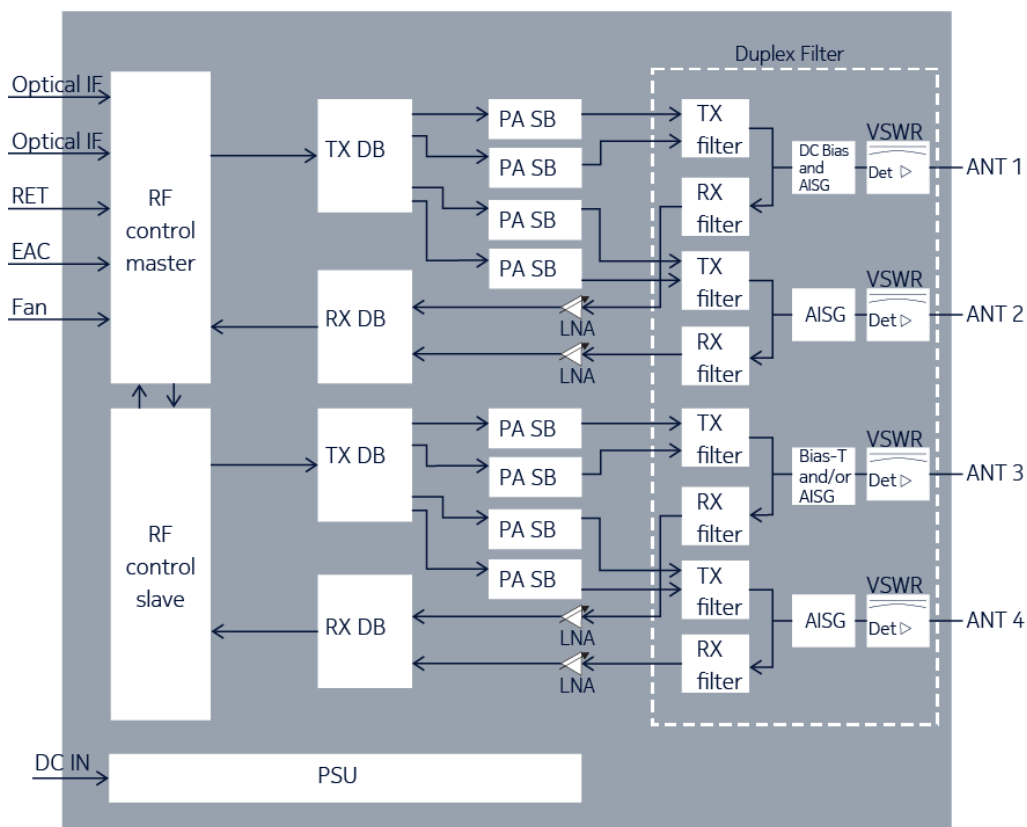

Electrical specifications

Table 378 AHFIG electrical specifications

Property	Value
Nominal supply voltage	-48.0 V DC

Table 378 AHFIG electrical specifications (Cont.)

Property	Value
Nominal input voltage range	–40.5 V DC to –57.0 V DC
Extended input voltage range	–36.0 V DC to –40.5 V DC –50 V DC to –60.0 V DC



Note: The minimum start-up voltage is –40.5 V DC. If the input voltage is below/beyond the extended limits, the unit might shut down.

Power consumption

Typical power consumption [W] for 48VDC input, at 25°C, representative of typical product performance under the same conditions (HW variant, SW version, configuration, environment, and so on) with +/- 10% margin. Average = (6h low hour load, 10h medium hour load and 8h busy hour load) / 24h

Configurations explained on examples:

- GSM/WCDMA: 2/2/2 = three sectors, two carriers/TRXs per sector
- LTE:
 - o 2/2/2 2Tx = three sectors, two carriers per sector, 2Tx per carrier
 - o 1+1/1+1/1+1 4Tx = three dual-band sectors, one carrier per sector per band, 4Tx per carrier

Some radio units are capable of providing only one sector coverage. Then the power values in the table consider deployment of three radio units.

Table 379 AHFIG power consumption in LTE mode

Configuration	Output Power per carrier (W)	Power consumption (W), ETSI 202706 average load P_{RRH} , static	Power consumption (W), ETSI 202706 busy hour load $P_{BH RRH}$, static	Power consumption (W), 100% RF power load $P_{100\% RRH}$
Single band 1/1/1 4Tx	4x80	2113	2586	3831
Single band 1/1/1 4Tx	4x40	1720	1967	2553
Single band 1/1/1 2Tx	2x80	1388	1622	2208
Single band 1/1/1 2Tx	2x40	1195	1313	1597
Dual band 1+1 / 1+1 / 1+1 4Tx	4x80 + 4x40	2869	3626	5175
Dual band 1+1 / 1+1 / 1+1 4Tx	4x40	2474	2992	4235
Dual band 1+1 / 1+1 / 1+1 2Tx	2x80 + 2x40	1757	2123	2890
Dual band 1+1 / 1+1 / 1+1 2Tx	2x40	1572	1830	2432

Power reduction

Table 380 Recommended AHFIG power reduction per band, in 256 QAM

Single carrier [dB]	Dual carrier [dB]	Triple carrier [dB]	Quad carrier [dB]
0	0.7	0.7	0.9



Note: The maximum power reduction (dlCellPwrRed) value is 20 dB. High power reduction values may cause radio outages.

Related optional items

- AMBF AirScale Book Mount Kit 126-150 (474278A)
- FPKA Flexi Pole Mounting Kit (471649A)
- FPKC Flexi Pole Mounting Kit (472821A)
- AMPA Pole Mounting (473879A)
- AMFD AirScale 2 FPKx Fixing Adapter 600 (474293A)
- ASAA AirScale 2 MDR26-open EAC cable (474288A)
- AMRA AirScale one clip bracket 51-125 (474580A)
- AMRC AirScale one clip rail 600 mm (474583A)
- ACPB AirScale 2 Fiber connector R2CT (474384A)

Installation options

- Wall installation
- Pole installation
- Vertical book mount
- Horizontal book mount
- One-clip rail installation

Dimensions and weight

Table 381 AHFIG dimensions and weight

Property	Value	Dimensions orientation
Height	Core RRH: 695 mm (27.36 in.) With upper and lower mounting brackets: 730 mm (28.74 in.)	
Width	Core RRH: 308 mm (12.13 in.) With mounting cover: 327 mm (12.87 in.)	
Depth	Core RRH: 131 mm (5.15 in.) With mounting cover: 142 mm (5.59 in.)	
Weight	Core RRH: 32 kg (70.6 lb)	
Volume	Core RRH: 31 l	

Environmental specifications

Table 382 AHFIG environmental specifications

Property	Value
Maximum operational outdoor temperature (in the shade)	55°C (131°F)
Maximum operational outdoor temperature (in the sun)	55°C (131°F)
Maximum indoor temperature	45°C (113°F)
Minimum operational temperature	-35°C (-31°F)
IP rating	IP65

LTE5213 feature interdependencies

The *LTE5213: Nokia AirScale Dual RRH 4T4R B25/66 480 W* feature is impacted by the following features:

- *LTE112: Cell Bandwidth - 20 MHz* needs to be enabled to use LTE 20 MHz carriers.
- *LTE113: Cell Bandwidth - 15 MHz* needs to be enabled to use LTE 15 MHz carriers.
- *LTE114: Cell Bandwidth - 10 MHz* needs to be enabled to use LTE 10 MHz carriers.
- *LTE115: Cell Bandwidth - 5 MHz* needs to be enabled to use LTE 5 MHz carriers.
- *LTE116: Cell Bandwidth - 3 MHz* needs to be enabled to use LTE 3MHz carriers.
- *LTE117: Cell Bandwidth - 1.4 MHz* needs to be enabled to use LTE 1.4MHz carriers.
- With *LTE614: Distributed Site*, AHFIG can be used in distributed sites with up to 23 km fiber length to the system module.
- *LTE1103: Load based Power Saving for multi-layer networks* works when enabled in the settings.
- *LTE1203: Load based Power Saving with Tx path switching off* works when enabled in the settings.
- *LTE2428: Nokia CPRI in FDD-LTE* provides support for CPRI interface.
- *LTE2508: BTS Embedded Power Meter for Energy Efficiency Monitoring* works when enabled in the settings.
- With *LTE2541: Nokia CPRI RRH/RFM chaining*, AHFIG supports Nokia CPRI chain of up to four radio units.
- With *LTE:2556: Flexi Multiradio BTS Rx-Sniffing enhancements* AHFIG supports Rx-Sniffing.
- *LTE2863: PIM Cancellation for AirScale 2.0 Radios* needs to be enabled to activate PIM cancellation feature (licenced feature).
- *LTE3036: Micro DTX extension* works when enabled in the settings.

5.3.16 Nokia AirScale Dual RRH 4T4R B25/B66a (n25/n66a) 160 W (AHFIA)

AHFIA is introduced by LTE3421, 5GC001441: Nokia AirScale Dual RRH 4T4R B25/B66a (n25/n66a) 160 W (AHFIA).

Functional description

Table 383 AHFIA functional specification

Property	Value
Output power	2x4x20 W with up to 4x20 W for single band operation
QAM modulation	256 QAM (DL) 64 QAM (UL)
Number of TXRX	B25/n25: 4T4R B66a/n66a: 4T4R
Outdoor installation	Yes
Supported technologies (standalone and MSR)	FDD-LTE, 5G
TX frequency range	B25/n25: 1930 – 1995 MHz B66a/n66a: 2110 – 2180 MHz
RX frequency range	B25/n25: 1850 – 1915 MHz B66a/n66a: 1710 – 1780 MHz
DL filter bandwidth	B25/n25: 65 MHz B66a/n66a: 70 MHz
UL filter bandwidth	B25/n25: 65 MHz B66a/n66a: 70 MHz
iBW (instantaneous bandwidth)	B25/n25: 65 MHz B66a/n66a: 70 MHz
oBW (occupied bandwidth)	B25/n25: 65 MHz B66a/n66a: 70 MHz
Number of carriers per pipe	Up to 8 carriers in total for all supported RATs
Supported bandwidths	LTE: 1.4, 3, 5, 10, 15, 20 MHz 5G: 5, 10, 15, 20 MHz
PIM cancellation	Yes

Interfaces

Figure 103 AHFIA interfaces

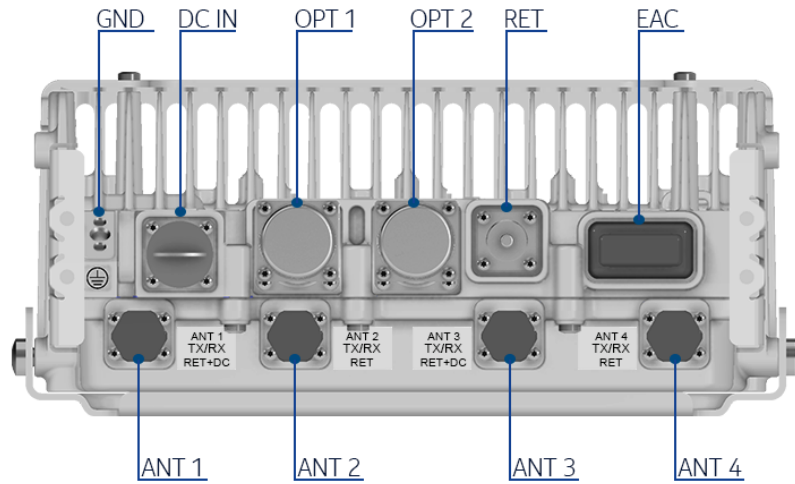

Table 384 AHFIA interfaces

Interface	Label on the HW	Number of interfaces	Connector type	Additional info
Power Connector	DC IN	1	High power circular	APPB, APPC
Antenna connector	ANT	4	4.3-10	AISG on all ports, BiasT support on ANT1 & ANT3 Has features that prevent damage if mating with a 4.1-9.5 connector is attempted
Remote Electrical Tilt	RET	1	8-pin circular	RS-485
External Alarm Connection	EAC	1	MDR-26	4 alarm inputs and 1 control output
Optical interface	OPT	2	SFP+ (R2CT)	9.8 Gbps, CPRI; R2CT IP seal
Grounding		1	M8 or dual M5 screws	-
Fan	FAN	1	Nokia fan	Located on the heat sink side



WARNING! Risk of electric shock

Before turning RF power on, RF ports have to be terminated by nominal 50 Ω load (for example, feeder with antenna). However, if these conditions are not met, the plastic caps that are delivered within the unused RF ports should remain in place. The plastic caps isolate RF port from the environment, and thus provide electric shock security in case RF power is accidentally on.

Antenna Line Devices (ALDs) support

Table 385 AHFIA ALD support

ALD support	Value
AISG	2.0, 3.0
CWA (for non-AISG installations)	No
Voltage	14.5 V (ANT1 and ANT3 only)
Power per port	30 W, 45 W total

Functional block diagram

Figure 104 AHFIA functional block diagram

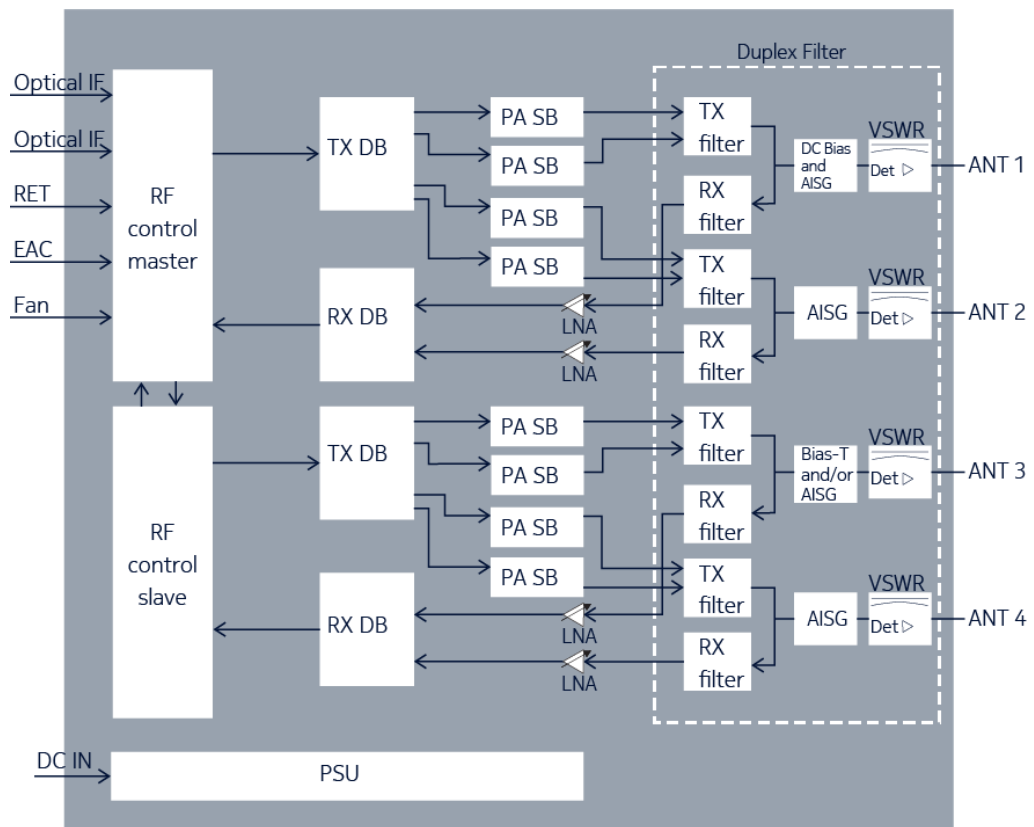

Electrical specifications

Table 386 AHFIA electrical specifications

Property	Value
Nominal supply voltage	-48.0 V DC

Table 386 AHFIA electrical specifications (Cont.)

Property	Value
Nominal input voltage range	-40.5 V DC to -57.0 V DC
Extended input voltage range	-36.0 V DC to -40.5 V DC -57.0 V DC to -60.0 V DC



Note: The minimum start-up voltage is -40.5 V DC. If the input voltage is below/beyond the extended limits, the unit might shut down.

Power consumption

Typical power consumption [W] for 48VDC input, at 25°C , representative of typical product performance under the same conditions (HW variant, SW version, configuration, environment, and so on) with $\pm 10\%$ margin. Average = (6h low hour load, 10h medium hour load and 8h busy hour load) / 24h

Configurations explained on examples:

- GSM/WCDMA: 2/2/2 = three sectors, two carriers/TRXs per sector
- LTE:
 - o 2/2/2 2Tx = three sectors, two carriers per sector, 2Tx per carrier
 - o 1+1/1+1/1+1 4Tx = three dual-band sectors, one carrier per sector per band, 4Tx per carrier

Some radio units are capable of providing only one sector coverage. Then the power values in the table consider deployment of three radio units.

Table 387 AHFIA power consumption in LTE mode

Configuration	Output power per carrier [W]	Power consumption ETSI 202706 average P_{RRH} , static	Power consumption ETSI 202706 busy hour load $P_{BH\ RRH}$, static	Power consumption 100% RF power load $P_{100\% \ RRH}$
Single band 1/1/1 4Tx	4x40	1341	1583	2104
Single band 1/1/1 4Tx	4x20	1142	1277	1558
Single band 1/1/1 2Tx	2x40	982	1106	1371
Single band 1/1/1 2Tx	2x20	878	948	1088
Dual band 1+1 / 1+1 / 1+1 4Tx	4x20	1644	1900	2449
Dual band 1+1 / 1+1 / 1+1 4Tx	4x10	1428	1574	1864
Dual band 1+1 / 1+1 / 1+1 2Tx	2x40	1330	1569	2110

Table 387 AHFIA power consumption in LTE mode (Cont.)

Configuration	Output power per carrier [W]	Power consumption ETSI 202706 average P_{RRH} , static	Power consumption ETSI 202706 busy hour load $P_{BH\ RRH}$, static	Power consumption 100% RF power load $P_{100\% \ RRH}$
Dual band 1+1 / 1+1 / 1+1 2Tx	2x20	1135	1266	1540

Power reduction

Table 388 Recommended AHFIA power reduction per band, in 256 QAM

Single carrier [dB]	Dual carrier [dB]	Triple carrier [dB]	Quad carrier [dB]
0	0.7	0.7	0.9



Note: The maximum power reduction ($dLCellPwrRed$) value is 20 dB. High power reduction values may cause radio outages.

Related optional items

- ASFC AirScale 2 fan unit 600 (474484A)
- AMBF AirScale book mount kit 126-150 (474278A)
- FPKA Flexi Pole Mounting Kit (30-120 mm) (471649A)
- FPKC Flexi Pole Mounting Kit (60-300 mm) (472821A)
- FPAE Flexi Power AC/DC Submodule 230V (472953A)
- APAF AirScale AC-DC PSU 208-240VAC/1150W (474676A)
- AMPA Pole Mounting Kit (30-120 mm) (473879A)
- AMFD AirScale 2 FPKx Fixing Adapter 600 (474293A)
- ASAA AirScale 2 MDR26-open EAC cable 5 m (474288A)
- APPB AirScale 2 55A DC plug 3.3-10 mm² (474282A)
- APPC AirScale 2 55A DC plug 10-16 mm² (474283A)
- ACPB AirScale 2 Fiber connector R2CT V2 (474384A)
- AMRA AirScale one clip bracket 51-125 (474580A)
- AMRC AirScale one clip rail 600 mm (474583A)

Installation options

- Wall installation
- Pole installation
- Vertical book mount
- Horizontal book mount (fan is required)
- One-clip rail installation



NOTICE: Install this RRH in a vertical orientation with connectors on the bottom side, to ensure convection cooling. For horizontal installation fans are required.

Dimensions and weight

Table 389 AHFIA dimensions and weight

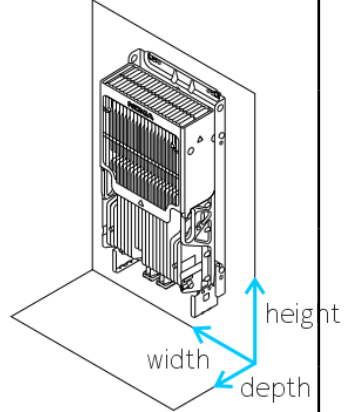
Property	Value	Dimensions orientation
Height	Core RRH: 560 mm (22.0 in.) With upper and lower mounting brackets: 675 mm (26.6 in.)	
Width	Core RRH: 308 mm (12.1 in.) With mounting brackets: 327 mm (12.9 in.)	
Depth	Core RRH: 129 mm (5.1 in.) With mounting brackets: 145 mm (5.7 in.)	
Weight	27 kg (59.5 lb)	

Environmental specifications

Table 390 AHFIA environmental specifications

Property	Value
Maximum operational outdoor temperature (in the shade) with fan or 10.8 km/h (6.7 mph) wind	55°C (131°F)
Maximum operational outdoor temperature (in the sun) with fan or 10.8 km/h (6.7 mph) wind	50°C (122°F)
Maximum indoor temperature	45°C (113°F)
Minimum operational temperature	-40°C (-40°F)
IP rating	IP65

LTE3421 feature interdependencies

The *LTE3421: Nokia AirScale Dual RRH 4T4R B25/B66a 160 W* feature is impacted by the following features:

- *LTE112: Cell Bandwidth - 20 MHz* needs to be enabled to use LTE 20 MHz carriers.
- *LTE113: Cell Bandwidth - 15 MHz* needs to be enabled to use LTE 15 MHz carriers.
- *LTE114: Cell Bandwidth - 10 MHz* needs to be enabled to use LTE 10 MHz carriers.
- *LTE115: Cell Bandwidth - 5 MHz* needs to be enabled to use LTE 5 MHz carriers.
- *LTE116: Cell Bandwidth - 3 MHz* needs to be enabled to use LTE 3 MHz carriers.
- *LTE117: Cell Bandwidth - 1.4 MHz* needs to be enabled to use LTE 1.4 MHz carriers.
- With *LTE614: Distributed Site*,

AHFIA can be used in distributed sites with up to 23 km fiber length to the system module.

- *LTE1103: Load based Power Saving for multi-layer networks* needs to be enabled to use Load based Power Saving for multi-layer networks.
- *LTE1203: Load based Power Saving with Tx path switching off* needs to be enabled to use Load based Power Saving with Tx path switching off.
- *LTE2508: BTS Embedded Power Meter for Energy Efficiency Monitoring* needs to be enabled to use BTS Embedded Power Meter for Energy Efficiency Monitoring.
- With *LTE2541: Nokia CPRI RRH/RFM chaining*, AHFIA supports Nokia CPRI chain of up to four radio units.
- *LTE2863: PIM Cancellation for AirScale 2.0 Radios* needs to be enabled to activate PIM cancellation feature (licenced feature).
- *LTE3036: Micro DTX extension* needs to be enabled to use Micro DTX extension.

5.4 Description of triple band radios

5.4.1 Nokia AirScale Tri RRH 2T2R B8/20/28 240 W (AHPMDA)

AHPMDA is introduced by LTE3142/SR001572: Nokia AirScale Tri RRH 2T2R B8/20/28 240 W (AHPMDA) .

Functional description

Table 391 AHPMDA functional specification

Property	Value
Output power	2x120 W (can be shared between the bands)
QAM	256 QAM (DL) 64 QAM (UL)
Number of TXRX	B28: 2T2R B20: 2T2R B8: 2T2R
Outdoor installation	Yes
Supported technologies (standalone and MSR)	GSM, WCDMA, FDD-LTE B8: GSM, WCDMA, FDD-LTE, GSM-WCDMA, WCDMA-LTE, GSM-LTE, GSM-WCDMA-LTE 5G-ready
TX frequency range	B28: 758 - 788 MHz B20: 791 - 821 MHz B8: 925 - 960 MHz

Table 391 AHPMDA functional specification (Cont.)

Property	Value
RX frequency range	B28: 703 - 733 MHz B20: 832 - 862 MHz B8: 880 - 915 MHz
DL filter bandwidth	B28: 30 MHz B20: 30 MHz B8: 35 MHz
UL filter bandwidth	B28: 30 MHz B20: 30 MHz B8: 35 MHz
iBW (instantaneous bandwidth)	B28: 30 MHz B20: 30 MHz B8: 35 MHz
oBW (occupied bandwidth)	B28: 30 MHz B20: 30 MHz B8: 35 MHz
Supported bandwidths	LTE: 1.4, 3, 5, 10, 15, 20 MHz
PIM cancellation	Yes

Interfaces

Figure 105 AHPMDA interfaces

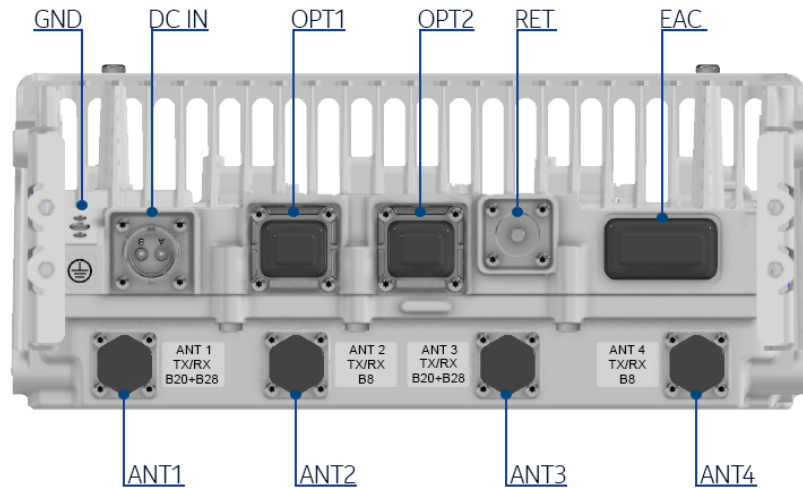



Table 392 AHPMDA interfaces

Interface	Label on the HW	Number of interfaces	Connector type	Additional info
Power Connector	DC IN	1	High power circular	Supports grounding for shielded cables; APPB, APPC
Antenna connector	ANT	4	4.3-10	AISG on each antenna connector Has features that prevent damage when mating with a 4.1-9.5 connector is attempted
Remote Electrical Tilt	RET	1	8-pin circular	RS-485
External Alarm Connection	EAC	1	MDR26	4 alarm inputs and 1 control output
Optical interface	OPT	2	SFP+	9.8 Gbps, CPRI; Nokia IP seal
Ground		1	M8 or dual M5 screws	-
Fan	FAN	1	Nokia fan	Located on the heat sink side



WARNING! Risk of electric shock

Before turning RF power on, RF ports have to be terminated by nominal 50 Ω load (for example, feeder with antenna). However, if these conditions are not met, the plastic caps that are delivered within the unused RF ports should remain in place. The plastic caps isolate RF port from the environment, and thus provide electric shock security in case RF power is accidentally on.

Antenna Line Devices (ALDs) support

Table 393 AHPMDA ALD support

ALD support	Value
AISG	2.0, 3.0
CWA (for non-AISG installations)	No
Voltage	14.5 V (ANT1 and ANT2 only)
Power per port	30 W, 45 W total

Functional block diagram

Figure 106 AHPMDA functional block diagram

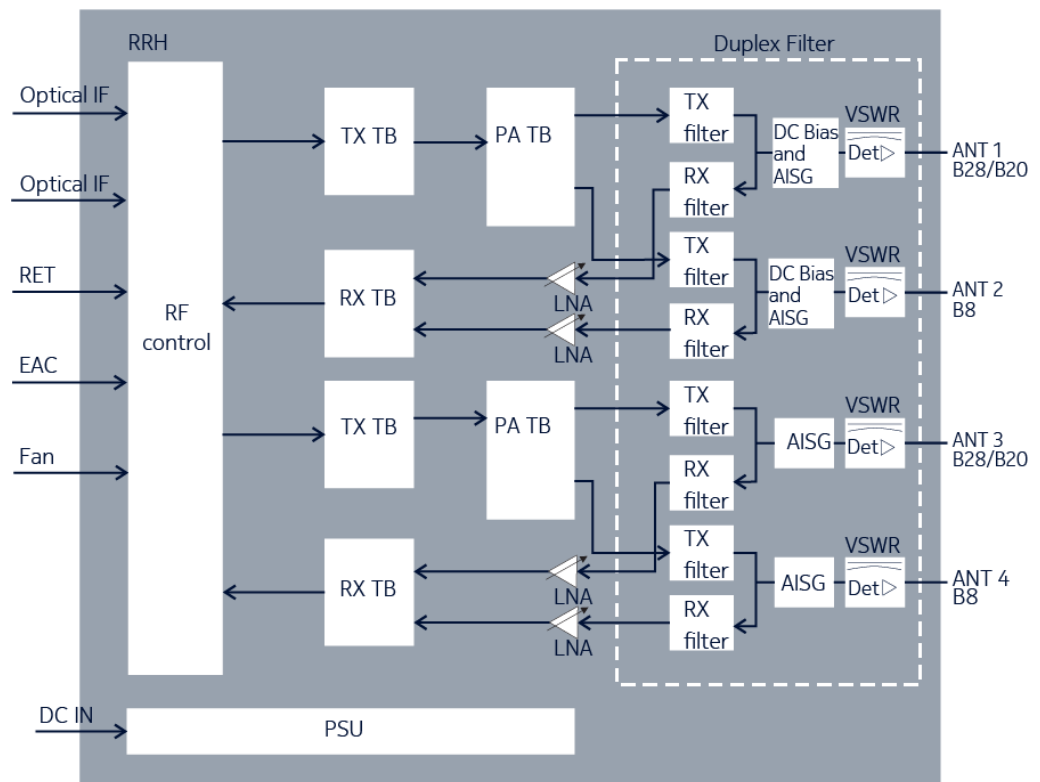

Electrical specifications

Table 394 AHPMDA electrical specifications

Property	Value
Nominal supply voltage	-48.0 V DC
Nominal input voltage range	-40.5 V DC to -57.0 V DC

Table 394 AHPMDA electrical specifications (Cont.)

Property	Value
Extended input voltage range	-36.0 V DC to -40.5 V DC -57.0 V DC to -60.0 V DC



Note: The minimum start-up voltage is -40.5 V DC. If the input voltage is below/beyond the extended limits, the unit might shut down.

Power consumption

Typical power consumption [W] for 48VDC input, at 25°C, representative of typical product performance under the same conditions (HW variant, SW version, configuration, environment, and so on) with +/- 10% margin. Average = (6h low hour load, 10h medium hour load and 8h busy hour load) / 24h

Configurations explained on examples:

- GSM/WCDMA: 2/2/2 = three sectors, two carriers/TRXs per sector
- LTE:
 - o 2/2/2 2Tx = three sectors, two carriers per sector, 2Tx per carrier
 - o 1+1/1+1/1+1 4Tx = three dual-band sectors, one carrier per sector per band, 4Tx per carrier

Some radio units are capable of providing only one sector coverage. Then the power values in the table consider deployment of three radio units.

Table 395 AHPMDA power consumption in LTE mode

Configuration	Output Power per carrier (W)	Power consumption (W), ETSI 202706 average load $P_{RRH, static}$	Power consumption (W), ETSI 202706 busy hour load $P_{BH, RRH, static}$	Power consumption (W), 100% RF power load $P_{100\% RRH}$
Triple band 1+1+1 / 1+1+1 / 1+1+1 2Tx	2x30 + 2x30 + 2x60	1624	2025	2918
Triple band 1+1+1 / 1+1+1 / 1+1+1 2Tx	2x20 + 2x20 + 2x40	1458	1762	2412
Triple band 1+1+1 / 1+1+1 / 1+1+1 2Tx	2x15 + 2x15 + 2x30	1343	1582	2075
Dual band (800/900) 1+1 / 1+1 / 1+1 2Tx	2x20 + 2x20	1202	1384	1716

Power reduction

Table 396 Recommended AHPMDA power reduction in 256 QAM (carrier spacing over 100 MHz)

Single carrier [dB]	Dual carrier [dB]	Triple carrier [dB]	Quad carrier [dB]
0	1.5	1.5	1.5



Note: The maximum power reduction (`dlCellPwrRed`) value is 20 dB. High power reduction values may cause radio outages.

Related optional items

- ASFC AirScale 2 fan unit 600 (474484A)
- AMBF AirScale book mount kit 126-150 (474278A)
- FPKA Flexi Pole Mounting Kit (30-120 mm) (471649A)
- FPKC Flexi Pole Mounting Kit (60-300 mm) (472821A)
- APAF AirScale AC-DC PSU 208-240VAC/1150W (474676A)
- AMPA Pole Mounting Kit (30-120 mm) (473879A)
- AMFD AirScale 2 FPKx Fixing Adapter 600 (474293A)
- ASAA AirScale 2 MDR26-open EAC cable 5 m (474288A)
- APPB AirScale 2 55A DC plug 3.3-10 mm² (474282A)
- APPC AirScale 2 55A DC plug 10-16 mm² (474283A)
- ACPA AirScale 2 Fiber Protection (474297A)
- AFPA Rejection Filter B28 703-789MHz (474704A)
- AMRA AirScale one clip bracket 51-125 (474580A)
- AMRC AirScale one clip rail 600 mm (474583A)

Installation options

- Wall installation
- Pole installation
- Vertical book mount
- Horizontal book mount (fan is required)
- RAS mounting capability
- One-clip rail installation



NOTICE: Install this RRH in a vertical orientation with connectors on the bottom side, to ensure convection cooling. For horizontal installation fans are required.

Dimensions and weight

Table 397 AHPMDA dimensions and weight

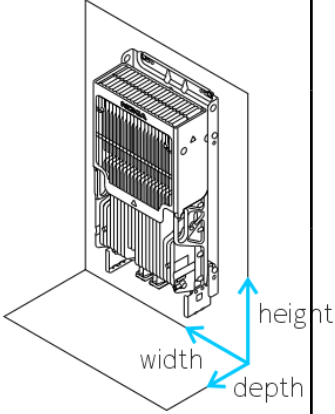
Property	Value	Dimensions orientation
Height	Core RRH: 512 mm (20.16 in.) With upper and lower mounting brackets: 652 mm (25.67 in.)	
Width	Core RRH: 308 mm (12.13 in.) With side mounting bosses: 327 mm (12.87 in.)	
Depth	Core RRH: 130 mm (5.12 in.) With mounting brackets: 142 mm (5.59 in.) With mounting bracket and heat shield: 147 mm (5.78 in.)	
Weight	24 kg (52.9 lb)	

Environmental specifications

Table 398 AHPMDA environmental specifications

Property	Value
Maximum operational outdoor temperature (in the shade) with fan or 10.8 km/h (6.7 mph) wind	55°C (131°F)
Maximum operational outdoor temperature (in the sun) with fan or 10.8 km/h (6.7 mph) wind	50°C (122°F)
Maximum indoor temperature	45°C (113°F)
Minimum operational temperature	-40°C (-40°F)
IP rating	IP65

LTE3142 feature interdependencies

The *LTE3142: Nokia AirScale Tri RRH 2T2R B8/20/28 240 W* feature is impacted by the following features:

- *LTE112: Cell Bandwidth - 20 MHz* needs to be enabled to use LTE 20 MHz carriers.
- *LTE113: Cell Bandwidth - 15 MHz* needs to be enabled to use LTE 15 MHz carriers.
- *LTE114: Cell Bandwidth - 10 MHz* needs to be enabled to use LTE 10 MHz carriers.
- *LTE115: Cell Bandwidth - 5 MHz* needs to be enabled to use LTE 5 MHz carriers.
- *LTE116: Cell Bandwidth - 3 MHz* needs to be enabled to use LTE 3 MHz carriers.
- *LTE117: Cell Bandwidth - 1.4 MHz* needs to be enabled to use LTE 1.4 MHz carriers.

- With *LTE614: Distributed Site*, AHPMDA can be used in distributed sites with up to 23 km fiber length to the system module.
- *LTE1103: Load based Power Saving for multi-layer networks* needs to be enabled to use Load based Power Saving for multi-layer networks.
- *LTE1203: Load based Power Saving with Tx path switching off* needs to be enabled to use Load based Power Saving with Tx path switching off.
- *LTE2508: BTS Embedded Power Meter for Energy Efficiency Monitoring* needs to be enabled to use BTS Embedded Power Meter for Energy Efficiency Monitoring.
- *LTE2541: Nokia CPRI RRH/RFM chaining* AHPMDA supports Nokia CPRI chain of up to four radio units.
- With *LTE3500: Supported RAS Installation options in FL17A Release*, RAS installation options are defined.
- *LTE3036: Micro DTX extension* allows further power saving.

5.4.2 Nokia AirScale Tri RRH 2T4R B5/8/28 (n5/n8/n28) 240 W (AHPADB)

AHPADB is introduced by SR002520/5GC002586: MSR support for AirScale Tri RRH 2T4R B5/8/28 (n5/n8/n28) 240 W AHPADB.

Functional description

Table 399 AHPADB functional specification

Property	Value
Output power	B5/B28 (n5/n28): 2 x 80 W B8/n8: 2 x 60 W Max power per antenna: 120 W Max power of RRH: 240 W
QAM	256 QAM (DL) 64 QAM (UL)
Number of TXRX	2T4R
Outdoor installation	Yes
Supported technologies (standalone and MSR)	B5, B28: FDD-LTE B8: WCDMA, LTE, WCDMA-LTE n5/n8/n28: 5G
IoT support	NB-IoT in band, guard band (GB), standalone (SA)
TX frequency range	B5/n5: 869 – 880 MHz B8/n8: 940 – 960 MHz B28/n28: 788 – 803 MHz

Table 399 AHPCDB functional specification (Cont.)

Property	Value
RX frequency range	B5/n5: 824 – 835 MHz B8/n8: 895 – 915 MHz B28/n28: 733 – 748 MHz
DL filter bandwidth	B5/n5: 11 MHz B8/n8: 20 MHz B28/n28: 15 MHz
UL filter bandwidth	B5/n5: 11 MHz B8/n8: 20 MHz B28/n28: 15 MHz
iBW (instantaneous bandwidth)	B5/n5: 11 MHz B8/n8: 20 MHz B28/n28: 15 MHz
oBW (occupied bandwidth)	B5/n5: 11 MHz B8/n8: 20 MHz B28/n28: 15 MHz
Number of carriers per pipe	Up to 16 carriers in total for all supported RATs
Supported bandwidths	B5/B8: 1.4, 3, 5, 10 MHz B28: 3, 5, 10, 15 MHz n5/n8: 5, 10 MHz n28: 5, 10, 15 MHz
PIM cancellation	Yes

Interfaces

Figure 107 AHPCDB interfaces

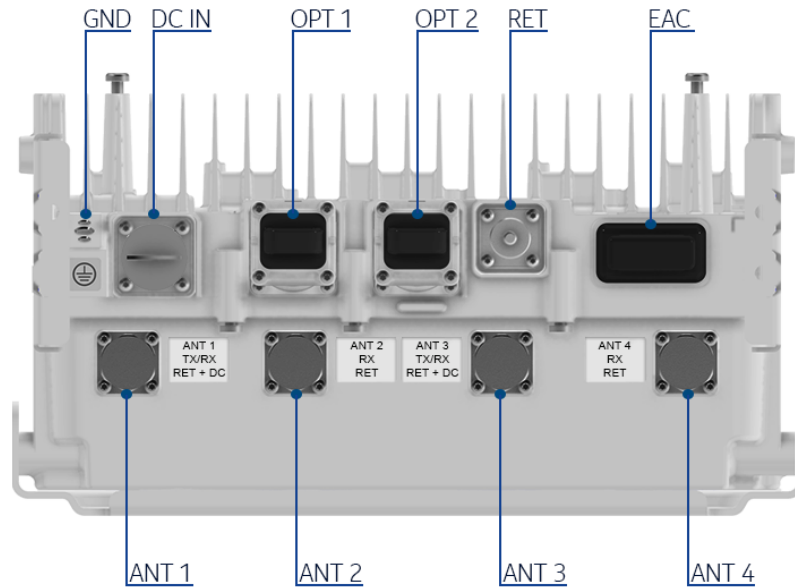

Table 400 AHPCDB interfaces

Interface	Label on the HW	Number of interfaces	Connector type	Additional info
Power connector	DC IN	1	High power circular	Supports grounding for shielded cables; APPB, APPC
Antenna connector	ANT	4	4.3-10+	AISG on each antenna connector Has features that prevent damage when mating with a 4.1-9.5 connector is attempted
Remote electrical tilt	RET	1	8-pin circular	RS-485
External alarm connection	EAC	1	MDR26	4 alarm inputs and 1 control output
Optical interface	OPT	2	SFP+	9.8 Gbps, CPRI; Nokia IP seal
Ground		1	M8 or 2xM5 screws	-
Fan	FAN	1	Nokia fan	Located on the heat sink side



WARNING! Risk of electric shock

Before turning RF power on, RF ports have to be terminated by nominal 50 Ω load (for example, feeder with antenna). However, if these conditions are not met, the plastic caps that are delivered within the unused RF ports should remain in place. The plastic caps isolate RF port from the environment, and thus provide electric shock security in case RF power is accidentally on.

Antenna Line Devices (ALDs) support

Table 401 AHPCDB ALD support

ALD support	Value
AISG	3.0
CWA (for non-AISG installations)	No
Voltage	14.5 V (ANT1 and ANT2 only)
Power per port	30 W, 45 W total

Functional block diagram

Figure 108 AHPCDB functional block diagram

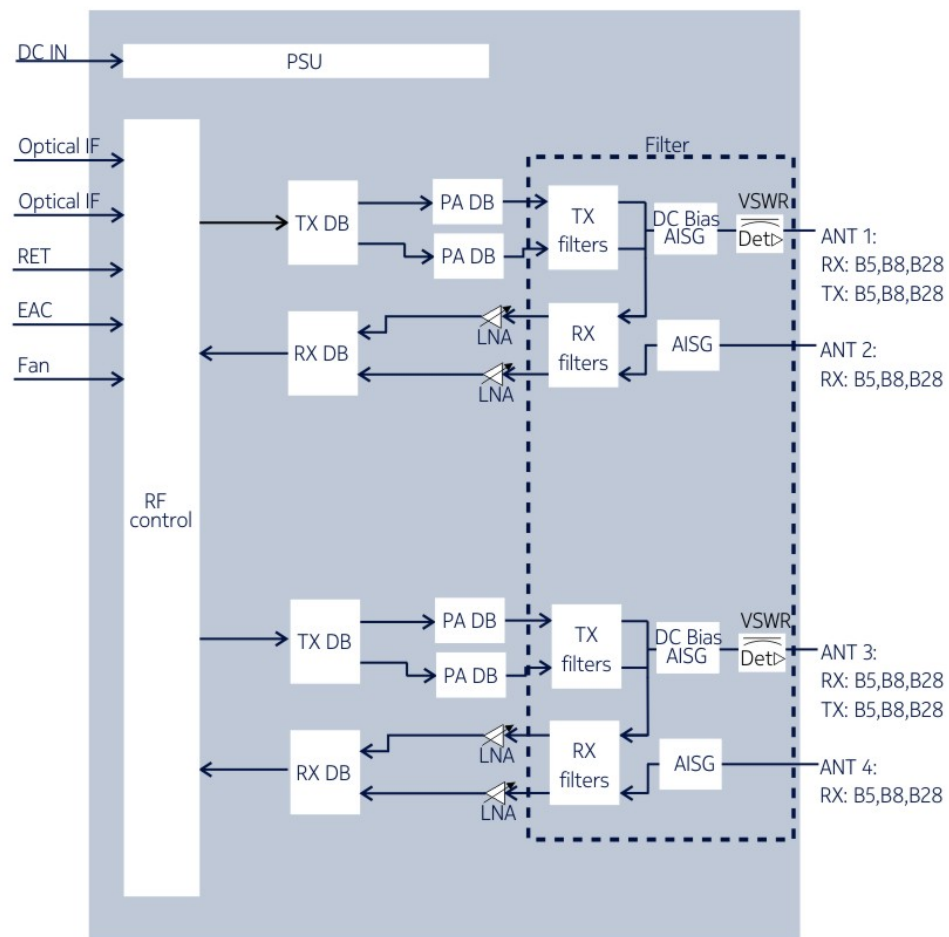

Electrical specifications

Table 402 AHPCDB electrical specifications

Property	Value
Nominal supply voltage	-48.0 V DC
Nominal input voltage range	-40.5 V DC to -57.0 V DC
Extended input voltage range	-36.0 V DC to -40.5 V DC -57.0 V DC to -60.0 V DC



Note: The minimum start-up voltage is -40.5 V DC. If the input voltage is below/beyond the extended limits, the unit might shut down.

Power consumption



Note: AHPCDB power consumption will be provided in future releases.

Power reduction



Note: The maximum power reduction (dCellPwrRed) value is 20 dB. High power reduction values may cause radio outages.

Related optional items

- ASFC AirScale 2 fan unit 600 (474484A)
- AMBG AirScale book mount kit 151-175 (474467A)
- FPKA Flexi Pole Mounting Kit (30-120 mm) (471649A)
- FPKC Flexi Pole Mounting Kit (60-300 mm) (472821A)
- APAF AirScale AC-DC PSU 208-240VAC/1150W (474676A)
- AMPA Pole Mounting Kit (30-120 mm) (473879A)
- AMFD AirScale 2 FPKx Fixing Adapter 600 (474293A)
- ASAA AirScale 2 MDR26-open EAC cable 5 m (474288A)
- APPB AirScale 2 55A DC plug 3.3-10 mm² (474282A)
- APPC AirScale 2 55A DC plug 10-16 mm² (474283A)
- ACPA AirScale 2 Fiber Protection (474297A)
- AFPA Rejection Filter B28 703-789MHz (474704A)
- AMRB AirScale one clip bracket 126-200 (474581A)
- AMRC AirScale one clip rail 600 mm (474583A)

Installation options

- Pole
- Wall
- Vertical book mount
- Horizontal book mount (fan is required)
- One-clip rail installation



NOTICE: Install this RRH in a vertical orientation with connectors on the bottom side, to ensure convection cooling. For horizontal installation fans are required.

Dimensions and weight

Table 403 AHPCDB dimensions and weight

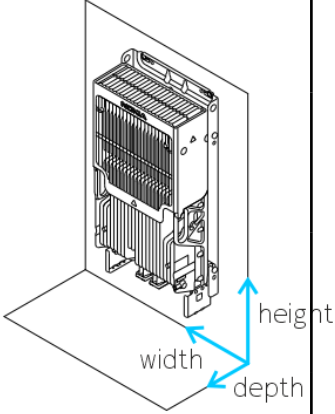
Property	Value	Dimensions orientation
Height	Core RRH: 512 mm (20.15 in.) With mounting bracket: 675 mm (26.57 in.)	
Width	Core RRH: 308 mm (12.13 in.) With side mounting bosses: 327 mm (12.87 in.)	
Depth	Core RRH: 165 mm (6.49 in.) With mounting bracket: 181 mm (7.13 in.)	
Weight	31 kg (68.3 lb)	

Environmental specifications

Table 404 AHPCDB environmental specifications

Property	Value
Maximum operational outdoor temperature (in the shade) with a minimum of wind of 10.8 km/h (6.7 mph)	50°C (122°F)
Maximum operational outdoor temperature (in the sun) with a minimum of wind of 10.8 km/h (6.7 mph)	55°C (131°F)
Maximum indoor temperature	45°C (113°F)
Minimum operational temperature	-40°C (-40°F)
IP rating	IP65

SR002520 feature interdependencies

The SR002520: MSR support for AirScale Tri RRH 2T4R B5/8/28 240 W AHPCDB feature is impacted by the following features:

- LTE113: Cell Bandwidth - 15 MHz needs to be enabled to use LTE 15 MHz carriers.
- LTE114: Cell Bandwidth - 10 MHz needs to be enabled to use LTE 10 MHz carriers.
- LTE115: Cell Bandwidth - 5 MHz needs to be enabled to use LTE 5 MHz carriers.
- LTE116: Cell Bandwidth - 3 MHz needs to be enabled to use LTE 3 MHz carriers.
- LTE117: Cell Bandwidth - 1.4 MHz needs to be enabled to use LTE 1.4 MHz carriers.
- With LTE614: Distributed Site, AHPCDB can be used in distributed sites with up to 23 km (14.29 mi) fiber length to the system module.
- With LTE1434: Flexi Multiradio BTS antenna Rx RF-sniffing AHPCDB supports rx-sniffing.
- With LTE2541: Nokia CPRI RRH/RFM chaining AHPCDB supports Nokia CPRI chain of up to four radio units.

- With *LTE2556: Flexi Multiradio BTS Rx-Sniffing enhancements* AHPMDB supports rx-sniffing.
- Power saving features:
 - *LTE1103: Load based Power Saving for multi-layer networks*
 - *LTE1203: Load based Power Saving with Tx path switching off*
 - *LTE2508: BTS Embedded Power Meter for Energy Efficiency Monitoring*
 - *LTE3036: Micro DTX extension*

5.4.3 Nokia AirScale Tri RRH 2T4R B8/20/28 (n8/n20/n28) 240 W (AHPMDB)

AHPMDB is introduced by SR002368/5GC001683: Nokia AirScale Tri RRH 2T2R B8/20/28 (n8/n20/n28) 240 W (AHPMDB).

Functional description

Table 405 AHPMDB functional specification

Property	Value
Output power	2 x 2 x 60 W (can be shared between the bands) Max power for RRH: 240 W
QAM	256 QAM (DL) 64 QAM (UL)
Number of TXRX	B8/n8: 2T4R B20/n20: 2T4R B28/n28: 2T4R
Outdoor installation	Yes
Supported technologies (standalone and MSR)	FDD-LTE, 5G B8/n8: GSM, WCDMA, FDD-LTE, GSM-WCDMA, WCDMA-LTE, GSM-LTE, GSM-WCDMA-LTE, 5G
IoT support	NB-IoT in band, guard band (GB), standalone (SA)
TX frequency range	B8/n8: 925–960 MHz B20/n20: 791–821 MHz B28/n28: 758–788 MHz
RX frequency range	B8/n8: 880–915 MHz B20/n20: 832–862 MHz B28/n28: 703–733 MHz

Table 405 AHPMDB functional specification (Cont.)

Property	Value
DL filter bandwidth	B8/n8: 35 MHz B20/n20: 30 MHz B28/n28: 30 MHz
UL filter bandwidth	B8/n8: 35 MHz B20/n20: 30 MHz B28/n28: 30 MHz
iBW (instantaneous bandwidth)	B8/n8: 35 MHz B20/n20: 30 MHz B28/n28: 30 MHz
oBW (occupied bandwidth)	B8/n8: 35 MHz B20/n20: 30 MHz B28/n28: 30 MHz
Number of carriers per pipe	2T2R: Up to 16 (across all bands) for all supported RATs 2T4R: Up to 8 (across all bands) for all supported RATs
Supported bandwidths	LTE B8: 1.4 MHz, 3 MHz, 5 MHz, 10 MHz LTE B20: 5 MHz, 10 MHz, 15 MHz, 20 MHz LTE B28: 3 MHz, 5 MHz, 10 MHz, 15 MHz, 20 MHz 5G: 5, 10, 15, 20 MHz
PIM cancellation	Yes

Interfaces

Figure 109 AHPMDB interfaces

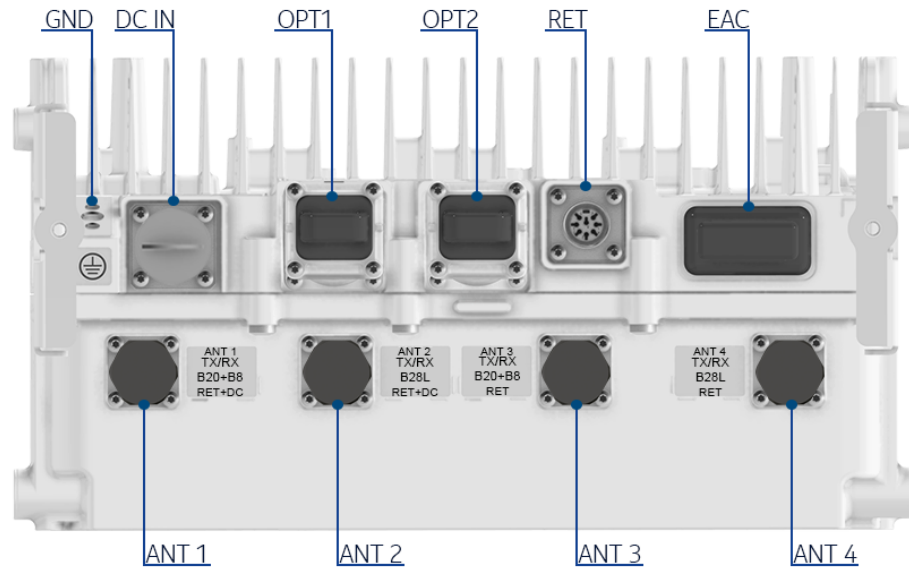

Table 406 AHPMDB interfaces

Interface	Label on the HW	Number of interfaces	Connector type	Additional info
Power Connector	DC IN	1	High power circular	Supports grounding for shielded cables; APPB, APPC
Antenna connector	ANT	4	4.3-10+	AISG on each antenna connector Has features that prevent damage when mating with a 4.1-9.5 connector is attempted
Remote Electrical Tilt	RET	1	8-pin circular	RS-485
External Alarm Connection	EAC	1	MDR26	4 alarm inputs and 1 control output
Optical interface	OPT	2	SFP+	9.8 Gbps, CPRI; Nokia IP seal
Ground		1	M8 or 2xM5 screws	-
Fan	FAN	1	Nokia fan	Located on the heat sink side



WARNING! Risk of electric shock

Before turning RF power on, RF ports have to be terminated by nominal 50 Ω load (for example, feeder with antenna). However, if these conditions are not met, the plastic caps that are delivered within the unused RF ports should remain in place. The plastic caps isolate RF port from the environment, and thus provide electric shock security in case RF power is accidentally on.

Antenna Line Devices (ALDs) support

Table 407 AHPMDB ALD support

ALD support	Value
AISG	3.0
CWA (for non-AISG installations)	No
Voltage	14.5 V (RET, ANT1, ANT2 only)
Power per port	30 W, 45 W total

Functional block diagram

Figure 110 AHPMDB functional block diagram

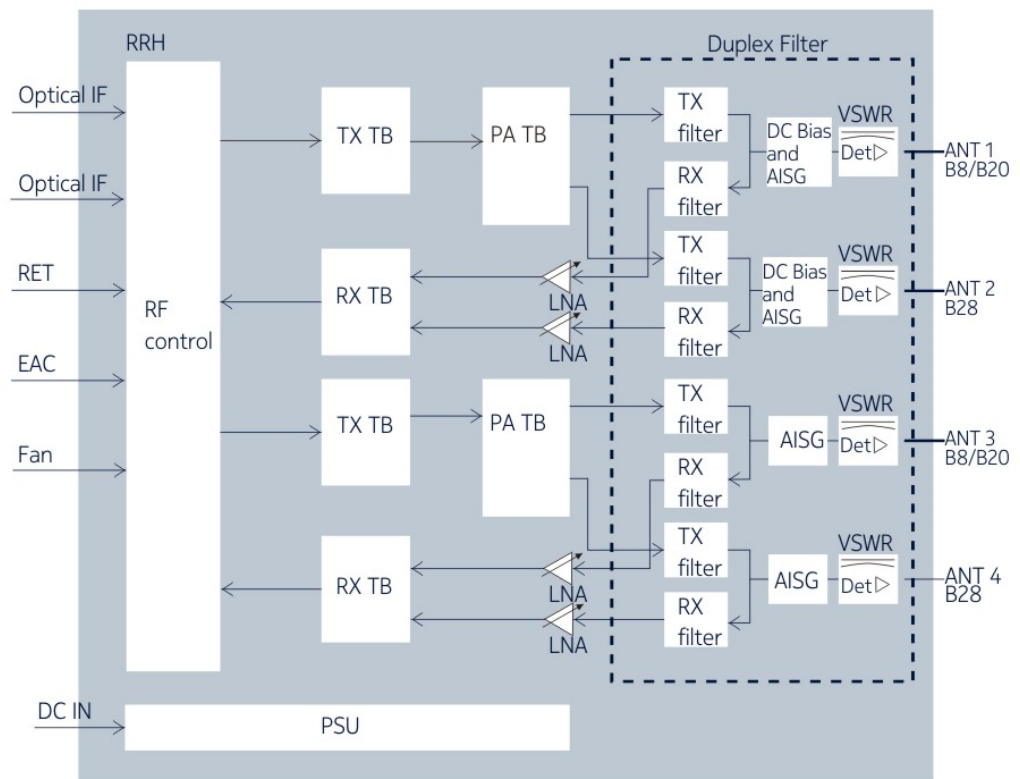

Electrical specifications

Table 408 AHPMDB electrical specifications

Property	Value
Nominal supply voltage	-48.0 V DC
Nominal input voltage range	-40.5 V DC to -57.0 V DC
Extended input voltage range	-36.0 V DC to -40.5 V DC -57.0 V DC to -60.0 V DC



Note: The minimum start-up voltage is -40.5 V DC. If the input voltage is below/beyond the extended limits, the unit might shut down.

Power consumption

AHPMDB power consumption will be provided in future releases.

Power reduction

Table 409 Recommended AHPMDB power reduction per band, in 256 QAM (carrier spacing over 100 MHz)

Single carrier [dB]	Dual carrier [dB]	Triple carrier [dB]	Quad carrier [dB]
0	1.5	1.5	1.5



Note: The maximum power reduction (`dlCellPwrRed`) value is 20 dB. High power reduction values may cause radio outages.

Related optional items

- ASFC AirScale 2 fan unit 600 (474484A)
- AMBG AirScale book mount kit 151-175 (474467A)
- FPKA Flexi Pole Mounting Kit (30-120 mm) (471649A)
- FPKC Flexi Pole Mounting Kit (60-300 mm) (472821A)
- APAF AirScale AC-DC PSU 208-240VAC/1150W (474676A)
- AMPA Pole Mounting Kit (30-120 mm) (473879A)
- AMFD AirScale 2 FPKx Fixing Adapter 600 (474293A)
- ASAA AirScale 2 MDR26-open EAC cable 5 m (474288A)
- APPB AirScale 2 55A DC plug 3.3-10 mm² (474282A)
- APPC AirScale 2 55A DC plug 10-16 mm² (474283A)
- ACPA AirScale 2 Fiber Protection (474297A)
- AFPA Rejection Filter B28 703-789MHz (474704A)
- AMRB AirScale one clip bracket 126-200 (474581A)
- AMRC AirScale one clip rail 600 mm (474583A)

Installation options

- Wall installation
- Pole installation
- Vertical book mount
- Horizontal book mount (fan is required)

- One-clip rail installation



NOTICE: Install this RRH in a vertical orientation with connectors on the bottom side, to ensure convection cooling. For horizontal installation fans are required.

Dimensions and weight

Table 410 AHPMDB dimensions and weight

Property	Value	Dimensions orientation
Height	Core RRH: 512 mm (20.15 in.) With mounting bracket: 652 mm (25.66 in.)	
Width	Core RRH: 308 mm (12.13 in.) With side mounting bosses: 327 mm (12.87 in.)	
Depth	Core RRH: 169 mm (6.65 in.) With mounting bracket: 185 mm (7.28 in.)	
Weight	31 kg (68.3 lb)	

Environmental specifications

Table 411 AHPMDB environmental specifications

Property	Value
Maximum operational outdoor temperature (in the shade) with fan or 10.8 km/h (6.7 mph) wind	55°C (131°F)
Maximum operational outdoor temperature (in the sun) with fan or 10.8 km/h (6.7 mph) wind	50°C (122°F)
Maximum indoor temperature	45°C (113°F)
Minimum operational temperature	-40°C (-40°F)
IP rating	IP65

SR002368 feature interdependencies

The SR002368: *Nokia AirScale Tri RRH 2T4R B8/20/28 240 W* feature is impacted by the following features:

- *LTE112: Cell Bandwidth - 20 MHz* needs to be enabled to use LTE 20 MHz carriers.
- *LTE113: Cell Bandwidth - 15 MHz* needs to be enabled to use LTE 15 MHz carriers.
- *LTE114: Cell Bandwidth - 10 MHz* needs to be enabled to use LTE 10 MHz carriers.
- *LTE115: Cell Bandwidth - 5 MHz*

- needs to be enabled to use LTE 5 MHz carriers.
- *LTE116: Cell Bandwidth - 3 MHz*
needs to be enabled to use LTE 3 MHz carriers.
- *LTE117: Cell Bandwidth - 1.4 MHz*
needs to be enabled to use LTE 1.4 MHz carriers.
- With *LTE614: Distributed Site*,
AHPMDB can be used in distributed sites with up to 23 km (14.29 mi) fiber length to the system module.
- With *LTE1434: Flexi Multiradio BTS antenna Rx RF-sniffing*
AHPMDB supports rx-sniffing.
- With *LTE2541: Nokia CPRI RRH/RFM chaining*
AHPMDB supports Nokia CPRI chain of up to four radio units.
- With *LTE2556: Flexi Multiradio BTS Rx-Sniffing enhancements*
AHPMDB supports rx-sniffing.
- Power saving features:
 - *LTE1103: Load based Power Saving for multi-layer networks*
 - *LTE1203: Load based Power Saving with Tx path switching off*
 - *LTE2508: BTS Embedded Power Meter for Energy Efficiency Monitoring*
 - *LTE3036: Micro DTX extension*

5.4.4 Nokia AirScale Tri RRH 4T4R B12/14/29 370 W (AHLBBA)

AHLBBA is introduced by LTE5210: AirScale RRH 4T4R B12/14/29 370 W (AHLBBA).

Functional description

Table 412 AHLBBA functional specification

Property	Value
Output power	2x105 W (B12/B14/B29) + 2x80 W (B12/B14) Max 370 W per RRH
QAM	256 QAM (DL) 64 QAM (UL)
Number of TXRX	B12: 4T4R B14: 4T4R B29: 2T
Outdoor installation	Yes
Supported technologies (standalone and MSR)	FDD-LTE, 5G-ready
TX frequency range	B12 (incl. B17): 729–745 MHz B14: 758–768 MHz B29: 717–728 MHz
RX frequency range	B12 (incl. B17): 699–715 MHz

Table 412 AHLBBA functional specification (Cont.)

Property	Value
	B14: 788–798 MHz
DL filter bandwidth	B12: 16 MHz B14: 10 MHz B29: 11 MHz
UL filter bandwidth	B12: 16 MHz B14: 10 MHz
DL iBW (instantaneous bandwidth)	B12: 16 MHz B14: 10 MHz B29: 11 MHz
UL iBW (instantaneous bandwidth)	B12: 16 MHz B14: 10 MHz
DL oBW (occupied bandwidth)	B12: 16 MHz B14: 10 MHz B29: 11 MHz
UL oBW (occupied bandwidth)	B12: 16 MHz B14: 10 MHz
Number of carriers per pipe	Up to 3
Supported bandwidths	LTE: 5, 10 MHz
PIM cancellation	Yes

Interfaces

Figure 111 AHLBBA interfaces

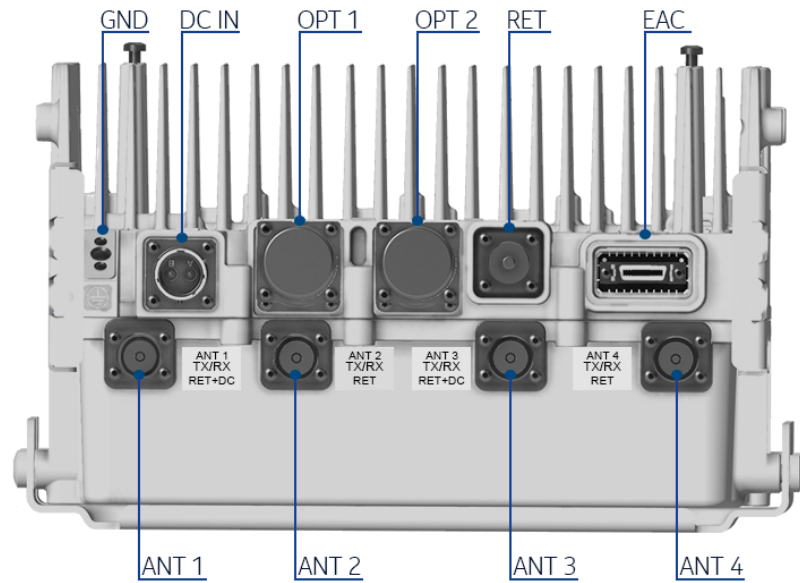

Table 413 AHLBBA interfaces

Interface	Label on the HW	Number of interfaces	Connector type	Additional info
Power Connector	DC IN	1	High power circular	APPB, APPC
Antenna connector	ANT	4	4.3-10	AISG on all ports, BiasT support on ANT1 and ANT3 Has features that prevent damage if mating with a 4.1-9.5 connector is attempted
Remote Electrical Tilt	RET	1	8-pin circular	RS-485
External Alarm Connection	EAC	1	MDR-26	4 alarm inputs and 1 control output
Optical interface	OPT	2	SFP+ (R2CT)	9.8 Gbps, CPRI; R2CT IP seal
Grounding		1	M8 or dual M5 screws	-
Fan	FAN	1	Nokia fan	Located on the heat sink side



WARNING! Risk of electric shock

Before turning RF power on, RF ports have to be terminated by nominal 50 Ω load (for example, feeder with antenna). However, if these conditions are not met, the plastic caps that are delivered within the unused RF ports should remain in place. The plastic caps isolate RF port from the environment, and thus provide electric shock security in case RF power is accidentally on.

Antenna Line Devices (ALDs) support

Table 414 AHLBBA ALD support

ALD support	Value
AISG	2.0, 3.0
CWA (for non-AISG installations)	No
Voltage	14.5 V (ANT1 and ANT3 only)
Power per port	30 W, 45 W total

Functional block diagram

Figure 112 AHLBBA functional block diagram

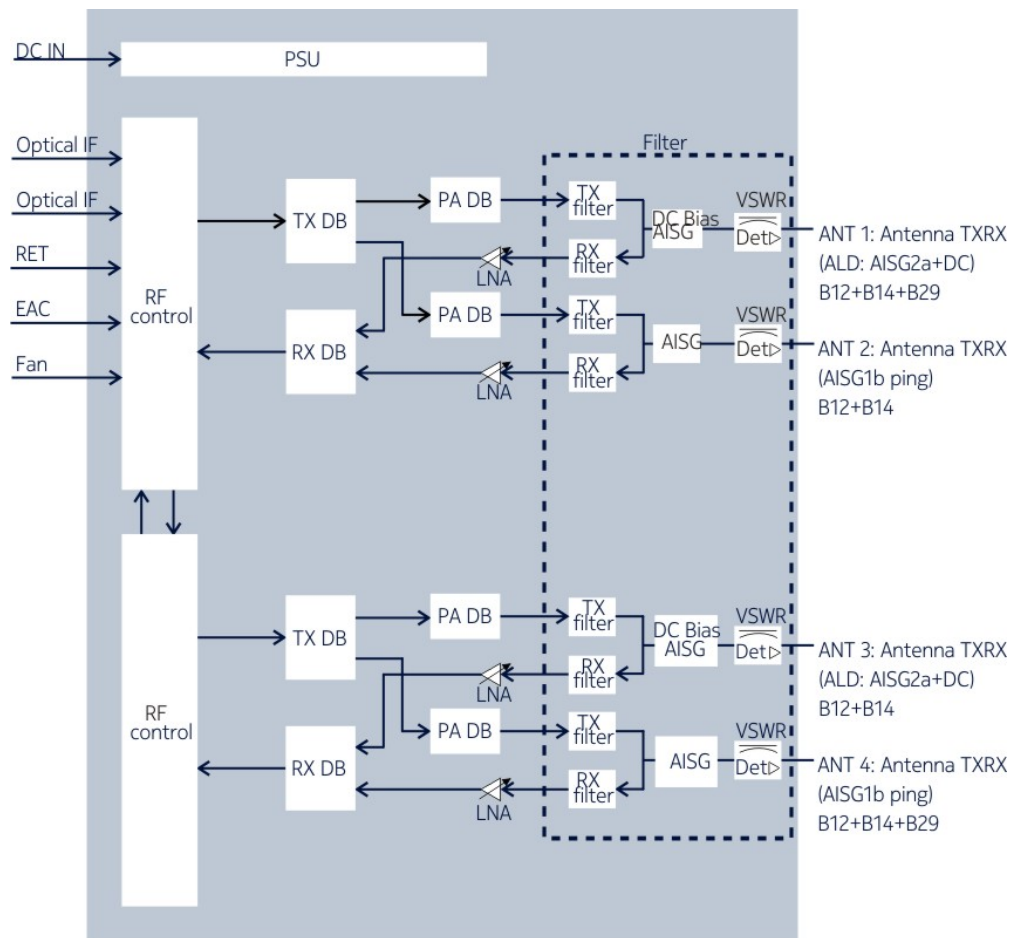

Electrical specifications

Table 415 AHLBBA electrical specifications

Property	Value
Nominal supply voltage	-48.0 V DC
Nominal input voltage range	-40.5 V DC to -57.0 V DC
Extended input voltage range	-36.0 V DC to -40.5 V DC -57.0 V DC to -60.0 V DC



Note: The minimum start-up voltage is -40.5 V DC. If the input voltage is below/beyond the extended limits, the unit might shut down.

Power consumption



Note: AHLBBA power consumption will be provided in future releases.

Power reduction

Table 416 Recommended AHLBBA power reduction in 256 QAM (carrier spacing over 100 MHz)

Single carrier [dB]	Dual carrier [dB]	Triple carrier [dB]	Quad carrier [dB]
0	1.5	1.5	1.5



Note: The maximum power reduction (`dlCellPwrRed`) value is 20 dB. High power reduction values may cause radio outages.

Related optional items

- ACPB AirScale 2 Fiber connector R2CT V2 (474384A)
- APPB AirScale 2 55A DC plug 3.3-10 mm2 (474282A)
- APPC AirScale 2 55A DC plug 10-16 mm2 (474283A)
- ASAA AirScale 2 MDR26-open EAC cable 5 m (474288A)
- FPKA Flexi Pole Mounting Kit (30-120 mm) (471649A)
- FPKC Flexi Pole Mounting Kit (60-300 mm) (472821A)
- AMFD AirScale 2 FPKx Fixing Adapter 600 (474293A)

Installation options

- Wall installation
- Pole installation



NOTICE: Install this RRH in a vertical orientation with connectors on the bottom side, to ensure convection cooling. For horizontal installation fans are required.

Dimensions and weight

Table 417 AHLBBA dimensions and weight

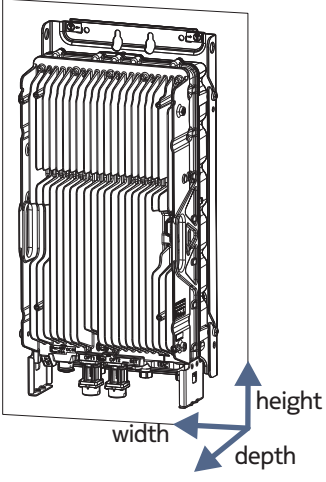
Property	Value	Dimensions orientation
Height	Core RRH: 610 mm (24.01 in.) With mounting bracket: 725 mm (28.54 in.)	
Width	Core RRH: 358 mm (14.09 in.) With mounting bracket: 377 mm (14.84 in.)	
Depth	Core RRH: 199 mm (7.83 in.) With mounting bracket: 215 mm (8.46 in.)	
Weight	46 kg (101.4 lb)	

Environmental specifications

Table 418 AHLBBA environmental specifications

Property	Value
Maximum operational outdoor temperature (in the shade) with a fan or 10.8 km/h (6.7 mph) wind	55°C (131°F)
Maximum operational outdoor temperature (in the sun) with a fan or 10.8 km/h (6.7 mph) wind	50°C (122°F)
Maximum indoor temperature	45°C (113°F)
Minimum operational temperature	-40°C (-40°F)
IP rating	IP65

LTE5210 feature interdependencies

The *LTE5210: Nokia AirScale RRH 4T4R B12/14/29 370 W (AHLBBA)* feature is impacted by the following features:

- *LTE114: Cell Bandwidth - 10 MHz* needs to be enabled to use LTE 10 MHz carriers.
- *LTE115: Cell Bandwidth - 5 MHz* needs to be enabled to use LTE 5 MHz carriers.
- With *LTE614: Distributed Site*, AHLBBA can be used in distributed sites with up to 23 km (14.29 mi) fiber length to the system module.
- With *LTE2541: Nokia CPRI RRH/RFM chaining*, AHLBBA supports Nokia CPRI chain of up to four radio units.
- *LTE2863: PIM Cancellation for AirScale 2.0 Radios* needs to be enabled to activate PIM cancellation feature (licensed feature).
- Power saving features:

- *LTE1103: Load based Power Saving for multi-layer networks*
- *LTE1203: Load based Power Saving with Tx path switching off*
- *LTE2508: BTS Embedded Power Meter for Energy Efficiency Monitoring*
- *LTE3036: Micro DTX extension*

6 Descriptions of Micro RRHs

6.1 Nokia AirScale Micro RRH 2T B46 UNII 1+3 1 W (AZRA)

AZRA is introduced by LTE3712: Nokia AirScale Micro RRH 2T B46 UNII 1+3 1 W (AZRA).

Functional description

Table 419 AZRA functional specification

Property	Value
Output power	2x0.5 W  Note: Due to low power and high-quality antenna connectors, the VSWR alarm reporting is not supported.
QAM	256 QAM (DL)
Number of TXRX	2T
Outdoor installation	Yes
Beamforming	No
Supported technologies (standalone and MSR)	LAA in FDD-LTE
Frequency range	UNII-1: 5170 – 5250 MHz UNII-3: 5735 – 5835 MHz
Filter bandwidth	UNII-1: 80 MHz UNII-3: 100 MHz
iBW (instantaneous bandwidth)	80 MHz
oBW (occupied bandwidth)	60 (80 MHz with LTE4224)
Number of carriers per pipe	Up to 3
Supported bandwidths	20 MHz

Interfaces

Figure 113 AZRA interfaces

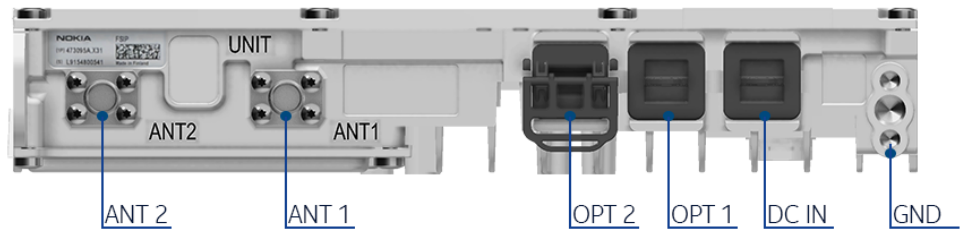

Table 420 AZRA interfaces

Interface	Label on the HW	Number of interfaces	Connector type	Additional info
Power Connector	DC IN	1	OCTIS Plug Kit DC Power	Hot insert not supported
Antenna connector	ANT	2	NEX 10	-
Optical interface	OPT	2	OCTIS Plug Kit SFP/SFP+	9.8 Gbps, CPRI
Grounding		1	M8 or dual M5	-



WARNING! Risk of electric shock

Before turning RF power on, RF ports have to be terminated by nominal 50Ω load (for example, feeder with antenna). However, if these conditions are not met, the plastic caps that are delivered within the unused RF ports should remain in place. The plastic caps isolate RF power from the environment, and thus provide electric shock security in case RF power is accidentally on.

Antenna Line Devices (ALDs) support



Note: There is no Antenna Line Device support for AZRA.

Functional block diagram

Figure 114 AZRA functional block diagram

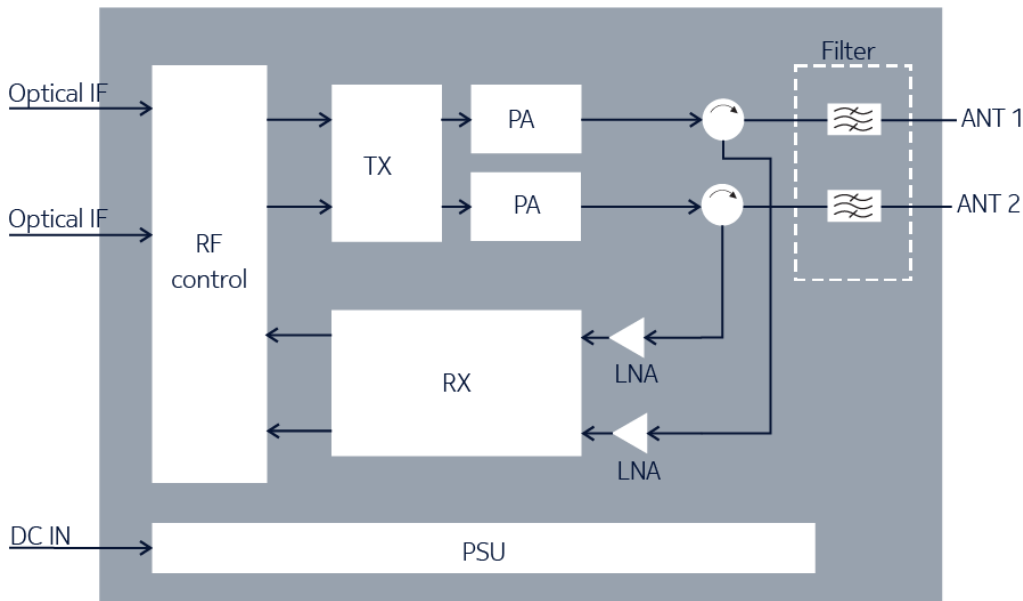

Electrical specifications

Table 421 AZRA electrical specifications

Property	Value
Nominal supply voltage	-48.0 V DC
Nominal input voltage range	-40.5 V DC to -57.0 V DC
Extended input voltage range	-36 V to -40.5 V and -57 V to -60 V (DC)



Note: The minimum startup voltage is -40.5 V DC. If the input voltage is below/beyond extended limits, unit might shut down.

Power consumption

Typical power consumption [W] for 48VDC input, at 25°C, representative of typical product performance under the same conditions (HW variant, SW version, configuration, environment, and so on) with +/- 10% margin. Average = (6h low hour load, 10h medium hour load and 8h busy hour load) / 24h

Configurations explained on examples:

- GSM/WCDMA: 2/2/2 = three sectors, two carriers/TRXs per sector
- LTE:
 - o 2/2/2 2Tx = three sectors, two carriers per sector, 2Tx per carrier
 - o 1+1/1+1/1+1 4Tx = three dual-band sectors, one carrier per sector per band, 4Tx per carrier

Some radio units are capable of providing only one sector coverage. Then the power values in the table consider deployment of three radio units.

Table 422 AZRA power consumption in LTE mode

Configuration	Output power per carrier [W]	Power consumption ETSI 202706 average load $P_{RRH, static}$	Power consumption ETSI 202706 busy hour load $P_{BH RRH, static}$	Power consumption 100% RF power load $P_{100\% RRH}$
1 sector 2Tx	2x0.5	53	54	56

Power reduction



Note: The maximum power reduction (`dlCellPwrRed`) value is 20 dB. High power reduction values may cause radio outages.

Related optional items

- APAB AirScale Micro AC PSU (474130A)
- OCTIS Plug Kit AC Power (474244A)
- OCTIS Plug Kit DC Power (474184A)
- OCTIS Plug Kit SFP (474183A)
- AARC AirScale Micro Integrated Antenna (474618A)
- AMBA AirScale Micro Bracket Assembly Kit (474182A)
- AMBC AirScale Micro Tilt Mount Kit (474332A)
- AMBM AirScale Micro Horizontal Strand Mount Bracket (474956A)
- FMWG AirScale Micro Wall/Pole Mount Kit for Single Radio (474013A)
- FMWH AirScale Micro Wall/Pole Mount Kit for Dual Radios (474312A)



Note: Refer to [Cabling Nokia AirScale Micro Remote Radio Heads](#) section in the [Installing and Cabling Nokia AirScale Micro Remote Radio Heads](#) document for a list of currently approved antennas for AZRA and AZRB B46 equipment.

Installation options

- Pole installation
- Wall installation
- Tilt installation
- Shroud installation
- Bookshelf installation



NOTICE: Always install this RRH in a vertical orientation with connectors on the bottom side, to ensure convection cooling.

Dimensions and weight

Table 423 AZRA dimensions and weight

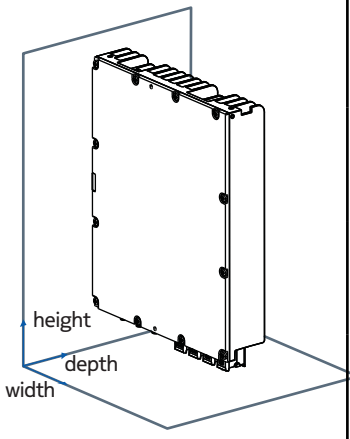
Property	Value	Dimensions orientation
Height	295 mm (11.6 in.)	
Depth	45 mm (1.8 in.)	
Width	245 mm (9.6 in.)	
Weight	max. 5 kg (11 lbs)	

Environmental specifications

Table 424 AZRA environmental specifications

Property	Value
Maximum operational outdoor temperature in the shade, assuming wind speed is 3 m/s (at constant high ambient temperature, maximum output power might be limited)	55°C (131°F)
Maximum operational outdoor temperature in the sun, assuming wind speed is 0.5 m/s (at constant high ambient temperature, maximum output power might be limited)	45°C (113°F)
Maximum indoor temperature	45°C (113°F)
Minimum operational temperature (including cold start)	-35°C (-31°F) Cold start from -40°C (-40°F)
IP rating	IP65

LTE3712 feature interdependencies

The *LTE3712: Nokia AirScale Micro RRH 2T B46 UNII 1 + 3 1 W* feature is impacted by the following features:

- With *LTE614: Distributed Site*, can be used in distributed sites with up to 23 km fiber length to the system module.
- *LTE1103: Load based Power Saving for multi-layer networks* or *LTE1203: Load based Power Saving with Tx path switching off* need to be enabled to use PA shutdown feature.
- *LTE2508: BTS Embedded Power Meter for Energy Efficiency Monitoring* needs to be enabled to use energy metering feature.
- With *LTE2541: Nokia CPRI RRH/RFM chaining*, AZRA supports Nokia CPRI chain of up to 4 radio units.

- With *LTE4224: Licensed-Assisted Access 5CC*, AZRA occupied bandwidth is increased to 80 MHz.

Warnings, cautions or notes related to the product



Note: For unlicensed band AZRA and AZRB B46 equipment, in accordance with KDB 353028 D01 Antennas Part 15 Transmitters and KDB 178919 D01 Permissive Change Policy v06; AZRA and AZRB B46 unlicensed band antennas cannot be substituted from those models used during the type approval process without first consulting your local Nokia account team. Additional regulatory approvals may be required.

6.2 Nokia AirScale Micro RRH 2T B46 UNII 1+2+3 1 W (AZRB)

AZRB is introduced by LTE4253: Nokia AirScale Micro RRH B46 2T 1 W (AZRB).

Functional description

Table 425 AZRB functional specification

Property	Value
Output power	2 x 0.5 W Note: Due to low power and high-quality antenna connectors, the VSWR alarm reporting is not supported.
QAM	256 QAM (DL)
Number of TXRX	2T
Outdoor installation	Yes
Supported technologies (standalone and MSR)	FDD-LTE
TX frequency range	UNII-1: 5170 – 5250 MHz UNII-2: 5250 – 5330 MHz UNII-2: 5490 – 5725 MHz Note: Due to type approval of <i>LTE4216: DFS Support for LAA</i> feature, usage of UNII-2 channels in AZRB is available from SW version FL18A 3.0 onwards. UNII-3: 5735 – 5835 MHz
Filter bandwidth	UNII-1: 80 MHz UNII-2: 80 MHz (not permitted yet) UNII-2: 235 MHz (not permitted yet) UNII-3: 100 MHz
iBW (instantaneous bandwidth)	80 MHz

Table 425 AZRB functional specification (Cont.)

Property	Value
oBW (occupied bandwidth)	60 (80 MHz with LTE4224)
Number of carriers per pipe	Up to 3
Supported bandwidths	20 MHz
PIM cancellation	No

Interfaces

Figure 115 AZRB interfaces

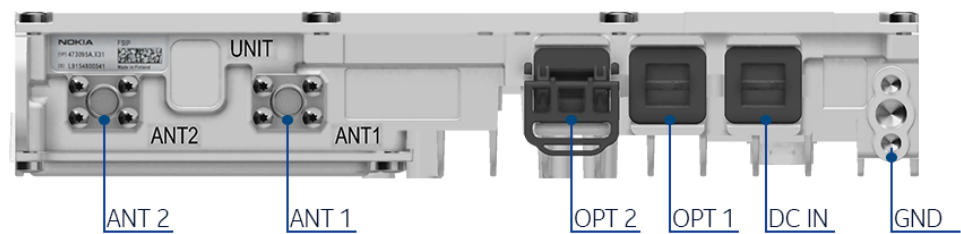

Table 426 AZRB interfaces

Interface	Label on the HW	Number of interfaces	Connector type	Additional info
Power Connector	DC IN	1	OCTIS Plug Kit DC Power	Hot insert not supported
Antenna connector	ANT	2	NEX 10	-
Optical interface	OPT	2	OCTIS Plug Kit SFP/SFP+	9.8 Gbps, CPRI
Grounding		1	M8 or dual M5 screws	-



WARNING! Risk of electric shock

Before turning RF power on, RF ports have to be terminated by nominal 50Ω load (for example, feeder with antenna). However, if these conditions are not met, the plastic caps that are delivered within the unused RF ports should remain in place. The plastic caps isolate RF power from the environment, and thus provide electric shock security in case RF power is accidentally on.

Antenna Line Devices (ALDs) support



Note: There is no Antenna Line Device support for AZRB.

Functional block diagram

Figure 116 AZRB functional block diagram

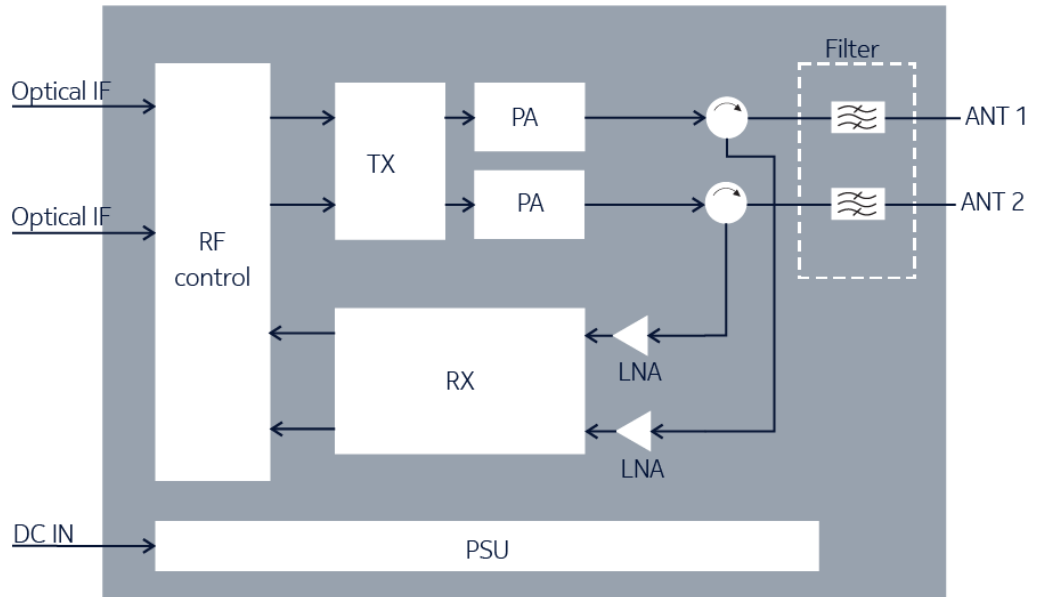

Electrical specifications

Table 427 AZRB electrical specifications

Property	Value
Nominal supply voltage	-48.0 V DC
Nominal input voltage range	-40.5 V DC to -57.0 V DC
Extended input voltage range	-36 V to -40.5 V and -57 V to -60 V (DC)



Note: The minimum startup voltage is -40.5 V DC. If the input voltage is below/beyond extended limits, unit might shut down.

Power consumption

Typical power consumption [W] for 48VDC input, at 25°C, representative of typical product performance under the same conditions (HW variant, SW version, configuration, environment, and so on) with +/- 10% margin. Average = (6h low hour load, 10h medium hour load and 8h busy hour load) / 24h

Configurations explained on examples:

- GSM/WCDMA: 2/2/2 = three sectors, two carriers/TRXs per sector
- LTE:
 - o 2/2/2 2Tx = three sectors, two carriers per sector, 2Tx per carrier
 - o 1+1/1+1/1+1 4Tx = three dual-band sectors, one carrier per sector per band, 4Tx per carrier

Some radio units are capable of providing only one sector coverage. Then the power values in the table consider deployment of three radio units.

Table 428 AZRB power consumption in LTE mode

Configuration	Output power per carrier [W]	Power consumption ETSI 202706 average load $P_{RRH, static}$	Power consumption ETSI 202706 busy hour load $P_{BH, RRH, static}$	Power consumption 100% RF power load $P_{100\% RRH}$
1 sector 2Tx	2x0.5	53	54	56

Power reduction



Note: The maximum power reduction ($dlCellPwrRed$) value is 20 dB. High power reduction values may cause radio outages.

Related optional items

- APAB AirScale Micro AC PSU (474130A)
- OCTIS Plug Kit AC Power (474244A)
- OCTIS Plug Kit DC Power (474184A)
- OCTIS Plug Kit SFP (474183A)
- AARC AirScale Micro Integrated Antenna (474618A)
- AMBA AirScale Micro Bracket Assembly Kit (474182A)
- AMBC AirScale Micro Tilt Mount Kit (474332A)
- AMBM AirScale Micro Horizontal Strand Mount Bracket (474956A)
- FMWG AirScale Micro Wall/Pole Mount Kit for Single Radio (474013A)
- FMWH AirScale Micro Wall/Pole Mount Kit for Dual Radios (474312A)
- FMWM AirScale Micro RRH Enclosure (474431A)
- FMWV AirScale Micro RRH Enclosure (475185A)



Note: Refer to [Cabling Nokia AirScale Micro Remote Radio Heads](#) section in the [Installing and Cabling Nokia AirScale Micro Remote Radio Heads](#) document for a list of currently approved antennas for AZRA and AZRB B46 equipment.

Installation options

- Pole mounting
- Wall mounting
- Bookshelf mounting
- Inside Enclosure



NOTICE: Always install this RRH in a vertical orientation with connectors on the bottom side, to ensure convection cooling.

Dimensions and weight

Table 429 AZRB dimensions and weight

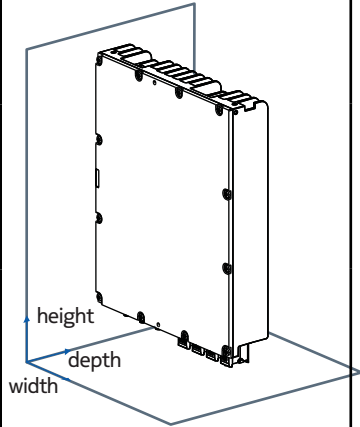
Property	Value	Dimensions orientation
Height	295 mm (11.6 in.)	
Depth	45 mm (1.8 in.) core unit (DC version) 55 mm (2.2 in.) with AC adapter (AC version)	
Width	245 mm (9.6 in.) core unit (DC version) 270 mm (10.6 in.) with AC adapter (AC version)	
Weight	5.0 kg (11.0 lb) core unit (DC version) 5.8 kg (12.8 lb) with AC adapter (AC version)	

Environmental specifications

Table 430 AZRB environmental specifications

Property	Value
Maximum operational outdoor temperature in the shade, assuming wind speed is 3 m/s (at constant high ambient temperature, maximum output power might be limited)	55°C (131°F)
Maximum operational outdoor temperature in the sun, assuming wind speed is 0.5 m/s (at constant high ambient temperature, maximum output power might be limited)	45°C (113°F)
Maximum indoor temperature	45°C (113°F)
Minimum operational temperature (including cold start)	-35°C (-31°F) Cold start from -40°C (-40°F)
IP rating	IP65

LTE4253 feature interdependencies

LTE4253: AirScale Micro RRH B46 2T 1W (AZRB) supports the following features:

- *LTE2860: Licensed-Assisted Access* required to support LAA operation in the 5 GHz spectrum.
- *LTE3664: LAA Micro RRH FDD Configurations for FSM4* enables LAA Configuration Feature.
- *LTE3635: LAA Dynamic Channel Selection for AirScale* enables dynamic channel selection (DCS) within the 5 GHz channels.
- *LTE4216: DFS Support for LAA* supports Radar Interference detection.

- *LTE1103: Load based Power Saving for multi-layer networks*
- *LTE2508: BTS Embedded Power Meter for Energy Efficiency Monitoring*
- *With LTE4224: Licensed-Assisted Access 5CC, AZRB occupied bandwidth is increased to 80 MHz.*

Warnings, cautions or notes related to the product



Note: For unlicensed band AZRA and AZRB B46 equipment, in accordance with KDB 353028 D01 Antennas Part 15 Transmitters and KDB 178919 D01 Permissive Change Policy v06; AZRA and AZRB B46 unlicensed band antennas cannot be substituted from those models used during the type approval process without first consulting your local Nokia account team. Additional regulatory approvals may be required.

6.3 Nokia AirScale Micro RRH 2T B46 UNII 1+2+3 1 W (AZRC)

AZRC is introduced by LTE4872: Nokia AirScale Micro RRH 2T 1 W B46 UNII 1+2+3 AZRC WW.

Functional description

Table 431 AZRC functional specification

Property	Value
Output power	2 x 0.5 W
QAM	256 QAM (DL)
Number of TXRX	2T
Outdoor installation	Yes
Supported technologies (standalone and MSR)	FDD-LTE
TX frequency range	UNII-1: 5170 – 5250 MHz UNII-2A: 5250 – 5330 MHz UNII-2C: 5490 – 5725 MHz Note: UNII-2C channels are supported by IC and ETSI regulatory domains. UNII-2 channels cannot be used until the full type approval for <i>LTE4788: ETSI and IC DFS Support for LAA</i> feature is available. UNII-3: 5735 – 5835 MHz Note: UNII-3 channels are supported by IC regulatory domain only.
Filter bandwidth	UNII-1: 80 MHz UNII-2A: 80 MHz

Table 431 AZRC functional specification (Cont.)

Property	Value
	UNII-2C: 235 MHz UNII-3: 100 MHz
iBW (instantaneous bandwidth)	80 MHz
oBW (occupied bandwidth)	60 (80 MHz with LTE4224)
Number of carriers per pipe	Up to 3
Supported bandwidths	20 MHz
PIM cancellation	No

Interfaces

Figure 117 AZRC interfaces

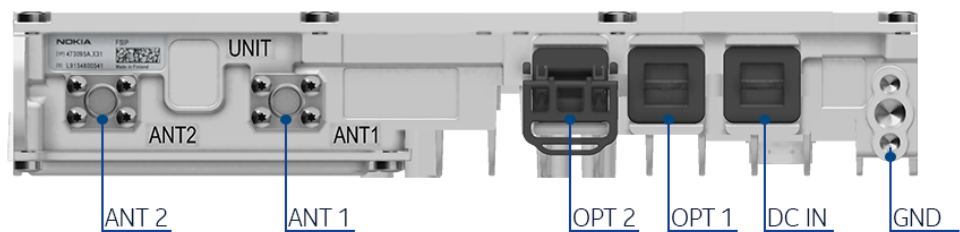

Table 432 AZRC interfaces

Interface	Label on the HW	Number of interfaces	Connector type	Additional info
Power connector	DC IN	1	OCTIS Plug Kit DC Power	Hot insert not supported
Antenna connector	ANT	2	NEX 10	-
Optical interface	OPT	2	OCTIS Plug Kit SFP/SFP+	9.8 Gbps, CPRI
Grounding		1	M8 or dual M5 screws	-



WARNING! Risk of electric shock

Before turning RF power on, RF ports have to be terminated by nominal 50Ω load (for example, feeder with antenna). However, if these conditions are not met, the plastic caps that are delivered within the unused RF ports should remain in place. The plastic caps isolate RF power from the environment, and thus provide electric shock security in case RF power is accidentally on.

Antenna Line Devices (ALDs) support



Note: There is no Antenna Line Device support on the AZRC.

Functional block diagram

Figure 118 AZRC functional block diagram

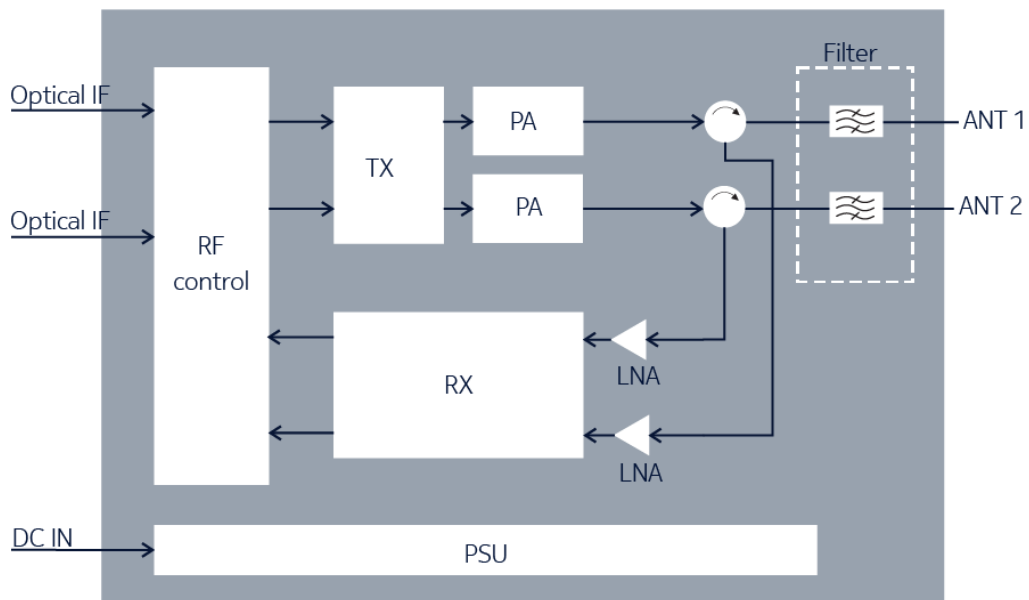

Electrical specifications

Table 433 AZRC electrical specifications

Property	Value
Nominal supply voltage	-48.0 V DC
Nominal input voltage range	-40.5 V DC to -57.0 V DC
Extended input voltage range	-36.0 V DC to -40.5 V DC -57.0 V DC to -60.0 V DC



Note: The minimum startup voltage is -40.5 V DC. If the input voltage is below/beyond extended limits, unit might shut down.

Power consumption

Typical power consumption [W] for 48VDC input, at 25°C, representative of typical product performance under the same conditions (HW variant, SW version, configuration, environment, and so on) with +/- 10% margin. Average = (6h low hour load, 10h medium hour load and 8h busy hour load) / 24h

Configurations explained on examples:

- GSM/WCDMA: 2/2/2 = three sectors, two carriers/TRXs per sector
- LTE:
 - o 2/2/2 2Tx = three sectors, two carriers per sector, 2Tx per carrier
 - o 1+1/1+1/1+1 4Tx = three dual-band sectors, one carrier per sector per band, 4Tx per carrier

Some radio units are capable of providing only one sector coverage. Then the power values in the table consider deployment of three radio units.

Table 434 AZRC power consumption in LTE mode

Configuration	Output power per carrier [W]	Power consumption ETSI 202706 average load $P_{RRH, static}$	Power consumption ETSI 202706 busy hour load $P_{BH, RRH, static}$	Power consumption 100% RF power load $P_{100\% RRH}$
1 sector 2Tx	2x0.5	53	54	56

Power reduction



Note: The maximum power reduction (`dlCellPwrRed`) value is 20 dB. High power reduction values may cause radio outages.

Related optional items

- APAB AirScale Micro AC PSU (474130A)
- OCTIS Plug Kit AC Power (474244A)
- OCTIS Plug Kit DC Power (474184A)
- OCTIS Plug Kit SFP (474183A)
- AARC AirScale Micro Integrated Antenna (474618A)
- AMBA AirScale Micro Bracket Assembly Kit (474182A)
- AMBC AirScale Micro Tilt Mount Kit (474332A)
- AMBM AirScale Micro Horizontal Strand Mount Bracket (474956A)
- FMWG AirScale Micro Wall/Pole Mount Kit for Single Radio (474013A)
- FMWH AirScale Micro Wall/Pole Mount Kit for Dual Radios (474312A)
- FMWM AirScale Micro RRH Enclosure (474431A)
- FMVW AirScale Micro RRH Enclosure (475185A)

Installation options

- Pole
- Wall
- Bookshelf
- Strand
- Enclosure



NOTICE: Always install this RRH in a vertical orientation with connectors on the bottom side, to ensure convection cooling.

Dimensions and weight

Table 435 AZRC dimensions and weight

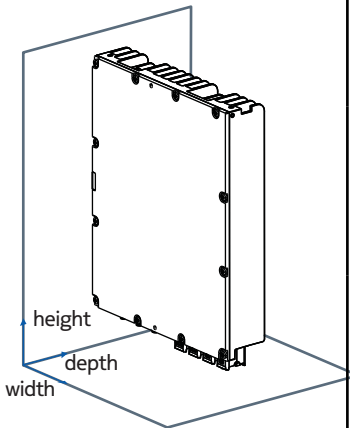
Property	Value	Dimensions orientation
Height	295 mm (11.61 in.)	
Width	Core RRH (DC version): 245 mm (9.65 in.) RRH with an AC adapter (AC version): 270 mm (10.63 in.)	
Depth	Core RRH (DC version): 45 mm (1.77 in.) RRH with an AC adapter (AC version): 55 mm (2.17 in.)	
Weight	Core RRH (DC version): 5.0 kg (11.0 lb) RRH with an AC adapter (AC version): 5.8 kg (12.8 lb)	

Environmental specifications

Table 436 AZRC environmental specifications

Property	Value
Maximum operational outdoor temperature in the shade, assuming wind speed is 3 m/s (at constant high ambient temperature, maximum output power might be limited)	55°C (131°F)
Maximum operational outdoor temperature in the sun, assuming wind speed is 0.5 m/s (at constant high ambient temperature, maximum output power might be limited)	45°C (113°F)
Maximum indoor temperature	45°C (113°F)
Minimum operational temperature (including cold start)	-35°C (-31°F) Cold start from -40°C (-40°F)
IP rating	IP65

LTE4872 feature interdependencies

The LTE4872: Nokia AirScale Micro RRH B46 2T 1W UNII 1+2+3 AZRC WW feature is impacted by the following features:

- LTE2860: Licensed-Assisted Access supports LAA operation in the 5 GHz spectrum.
- LTE3635: LAA Dynamic Channel Selection for AirScale enables Dynamic Channel Selection (DCS) within the 5 GHz channels.
- LTE3664: LAA Micro RRH FDD Configurations for FSM4 enables LAA configuration feature.

- *LTE3945: Partial Ending Sub-frame Support for LAA* support partial ending subframe (DwPTS) at the end of transmit burst in LAA.
- *LTE4216: DFS Support for LAA* supports radar interference detection.
- With *LTE4224: Licensed-Assisted Access 5CC*, AZRC occupied bandwidth is increased to 80 MHz.
- *LTE4788: ETSI and IC DFS Support for LAA* enables DFS support for AZRC.
- Power saving features:
 - *LTE1103: Load based Power Saving for multi-layer networks*
 - *LTE2508: BTS Embedded Power Meter for Energy Efficiency Monitoring*

6.4 Nokia AirScale Micro 4T4R B1 20 W (AHGB)

AHGB (474514A) is introduced by LTE4269/SR002040/5GC001484: Nokia AirScale Micro 4T4R B1 20 W (AHGB).

Functional description

Table 437 AHGB functional specification

Property	Value
Output power	4x5 W
QAM	256 QAM (DL) 64 QAM (UL)
Number of TXRX	4T4R
Outdoor installation	Yes
Supported technologies (standalone and MSR)	WCDMA, FDD-LTE, WCDMA-LTE, 5G
TX frequency range	2110–2170 MHz
RX frequency range	1920–1980 MHz
DL filter bandwidth	60 MHz
UL filter bandwidth	60 MHz
iBW (instantaneous bandwidth)	60 MHz
oBW (occupied bandwidth)	60 MHz
Number of carriers per pipe	Up to 4
Supported bandwidths	LTE: 5, 10, 15, 20 MHz 5G: 20 MHz

Interfaces

Figure 119 AHGB interfaces

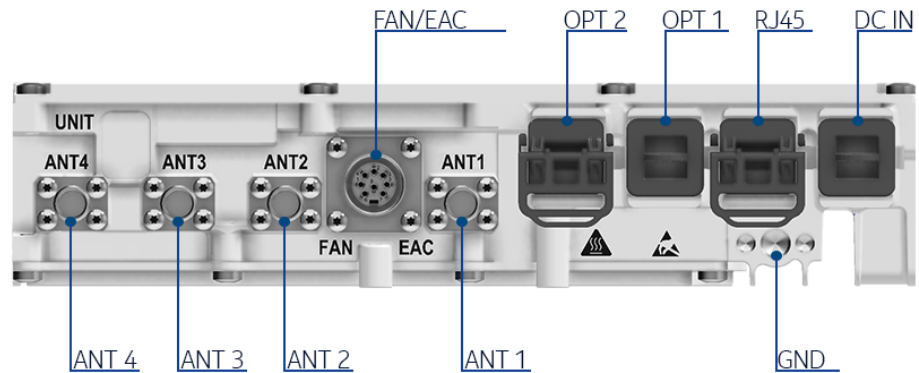



Table 438 AHGB interfaces

Interface	Label on the HW	Number of interfaces	Connector type	Additional info
Power Connector	DC IN	1	DC Octis Plug Kit	Hot insert not supported
Antenna connector	ANT	4	NEX 10	-
External Alarm Connection/Fan	EAC/FAN	1	CIRC 8F IP67 Flange	-
Optical interface	OPT	2	OCTIS Plug Kit SFP/SFP+	9.8 Gbps, CPRI
Ethernet	RJ	1	RJ45	Separate feature required to enable this interface
Grounding		1	M8 or dual M5 screws	-



WARNING! Risk of electric shock

Before turning RF power on, RF ports have to be terminated by nominal 50 Ω load (for example, feeder with antenna). However, if these conditions are not met, the plastic caps that are delivered within the unused RF ports should remain in place. The plastic caps isolate RF port from the environment, and thus provide electric shock security in case RF power is accidentally on.

Antenna Line Devices (ALDs) support



Note: There is no Antenna Line Device support for AHGB.

Functional block diagram

Figure 120 AHGB functional block diagram

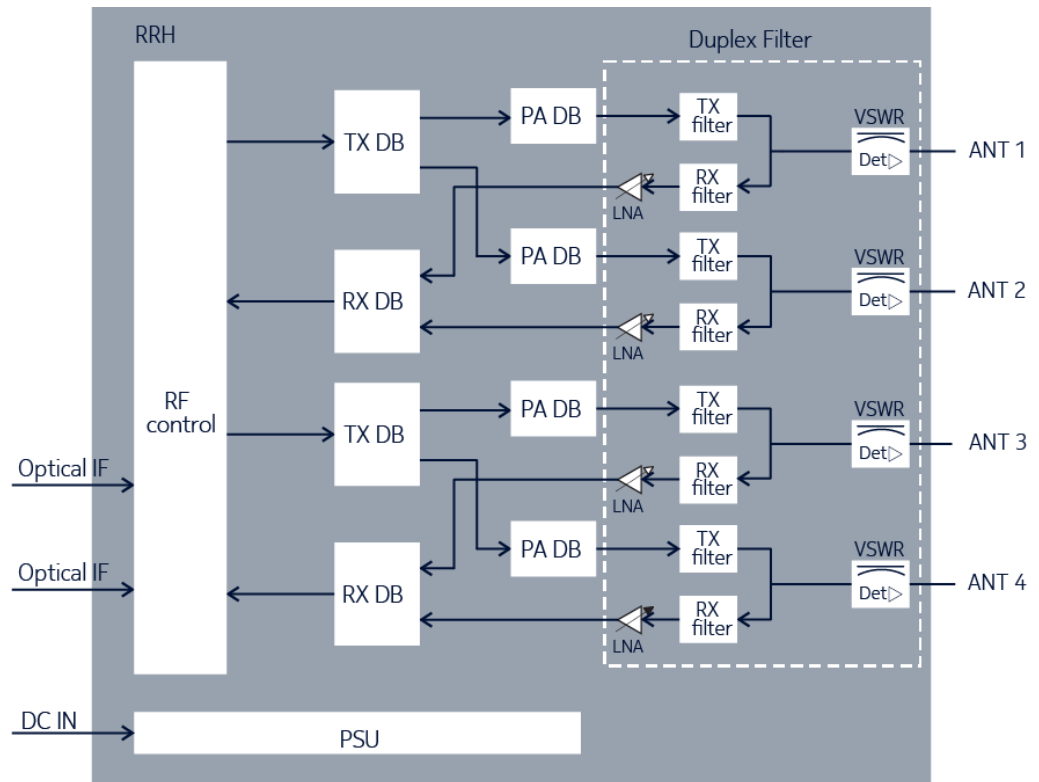

Electrical specifications

Table 439 AHGB electrical specifications

Property	Value
Nominal supply voltage	-48.0 V DC
Nominal input voltage range	-40.5 V DC to -57.0 V DC
Extended input voltage range	-36 V to -40.5 V and -57 V to -60 V (DC)

Note: The minimum startup voltage is -40.5 V DC. If the input voltage is below/beyond extended limits, the unit might shut down.

Power consumption

Note: AHGB power consumption will be provided in further releases.

Power reduction

Note: The maximum power reduction (dlCellPwrRed) value is 20 dB. High power reduction values may cause radio outages.

Related optional items

- APAB AirScale Micro AC PSU (474130A)
- OCTIS Plug Kit AC Power (474244A)

- OCTIS Plug Kit DC Power (474184A)
- OCTIS Plug Kit SFP (474183A)
- AMBA AirScale Micro Bracket Assembly Kit (474182A)
- AAFA AirScale Micro Integrated Antenna (474185A)
- AMBC AirScale Micro Tilt Mount Kit (474332A)
- AMBK AirScale Micro Horizontal Strand Mount Bracket (474630A)
- AMBL AirScale Micro Horizontal Strand Mount Bracket (474849A)
- FMWG AirScale Micro Wall/Pole Mount Kit for Single Radio (474013A)
- FMWH AirScale Micro Wall/Pole Mount Kit for Dual Radios (474312A)
- FMWM AirScale Micro RRH Enclosure (474431A)

Installation options

- Pole/wall installation
- Bookshelf mounting
- Tilt mounting
- Enclosure mounting
- Strand mounting



NOTICE: Always install this RRH in a vertical orientation with connectors on the bottom side, to ensure convection cooling.

Dimensions and weight

Table 440 AHGB dimensions and weight

Property	Value	Dimensions orientation
Height	295 mm (11.6 in.)	
Depth	55 mm (2.2 in.)	
Width	245 mm (9.6 in.)	
Weight	5.4 kg (11.7 lb) core unit (DC version) 6.1 kg (13.4 lb) with AC adapter (AC version)	

Environmental specifications

Table 441 AHGB environmental specifications

Property	Value
Maximum operational outdoor temperature (in the shade)	55°C (131°F)
Maximum operational outdoor temperature (in the sun)	45°C (113°F)
Maximum indoor temperature	45°C (113°F)

Table 441 AHGB environmental specifications (Cont.)

Property	Value
Minimum operational temperature (including cold start)	-35°C (-31°F) Cold start from -40°C (-40°F)
IP rating	IP65

Feature interdependencies

The *LTE4269: Nokia AirScale Micro 4T4R B1 20 W (AHGB)* feature is impacted by the following features:

- *LTE112: Cell Bandwidth - 20 MHz* enables LTE 20 MHz carriers.
- *LTE113: Cell Bandwidth - 15 MHz* enables LTE 15 MHz carriers.
- *LTE114: Cell Bandwidth - 10 MHz* enables LTE 10 MHz carriers.
- *LTE115: Cell Bandwidth - 5 MHz* enables LTE 5 MHz carriers.
- With *LTE614: Distributed Site*, AHGB can be used in distributed sites with up to 23km fiber length to the system module.
- *LTE1103: Load based Power Saving for multilayer networks*
- *LTE1203: Load based Power Saving mode with TX power reduction or path switching off*
- *LTE2508: BTS Embedded Power Meter for Energy Efficiency Monitoring*
- With *LTE2541: Nokia CPRI RRH/RFM chaining*, AHGB supports Nokia CPRI chain of up to 4 radio units.
- *LTE3036: Micro DTX extension*

6.5 Nokia AirScale Micro 4T4R B3 20 W (AHEJ)

AHEJ is introduced by LTE4270/5GC001485: Nokia AirScale Micro 4T4R B3 20 W (AHEJ).

Functional description

Table 442 AHEJ functional specification

Property	Value
Output power	4x5 W
QAM	256 QAM (DL) 64 QAM (UL)
Number of TXRX	4T4R
Outdoor installation	Yes
Supported technologies (standalone and MSR)	FDD-LTE, 5G
TX frequency range	1805–1880 MHz
RX frequency range	1710–1785 MHz

Table 442 AHEJ functional specification (Cont.)

Property	Value
DL filter bandwidth	75 MHz
UL filter bandwidth	75 MHz
iBW (instantaneous bandwidth)	75 MHz
oBW (occupied bandwidth)	75 MHz
Number of carriers per pipe	Up to 4
Supported bandwidths	LTE: 1.4, 3, 5, 10, 15, 20 MHz 5G: 20 MHz

Interfaces

Figure 121 AHEJ interfaces

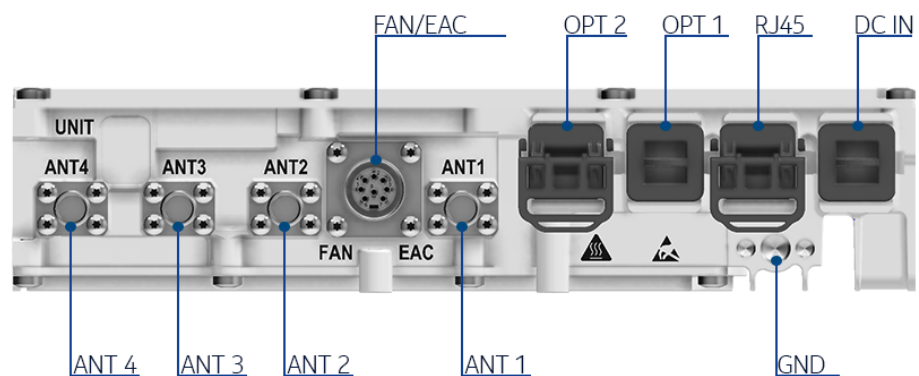



Table 443 AHEJ interfaces

Interface	Label on the HW	Number of interfaces	Connector type	Additional info
Power Connector	DC IN	1	DC Octis Plug Kit	Hot insert not supported
Antenna connector	ANT	4	NEX 10	-
External Alarm Connection/Fan	EAC/FAN	1	CIRC 8F IP67 Flange	-
Optical interface	OPT	2	OCTIS Plug Kit SFP/SFP+	9.8 Gbps, CPRI

Table 443 AHEJ interfaces (Cont.)

Interface	Label on the HW	Number of interfaces	Connector type	Additional info
Ethernet	RJ	1	RJ45	Separate feature required to enable this interface
Grounding		1	M8 or dual M5 screws	-



WARNING! Risk of electric shock

Before turning RF power on, RF ports have to be terminated by nominal 50 Ω load (for example, feeder with antenna). However, if these conditions are not met, the plastic caps that are delivered within the unused RF ports should remain in place. The plastic caps isolate RF port from the environment, and thus provide electric shock security in case RF power is accidentally on.

Antenna Line Devices (ALDs) support



Note: There is no Antenna Line Device support for AHEJ.

Functional block diagram

Figure 122 AHEJ functional block diagram

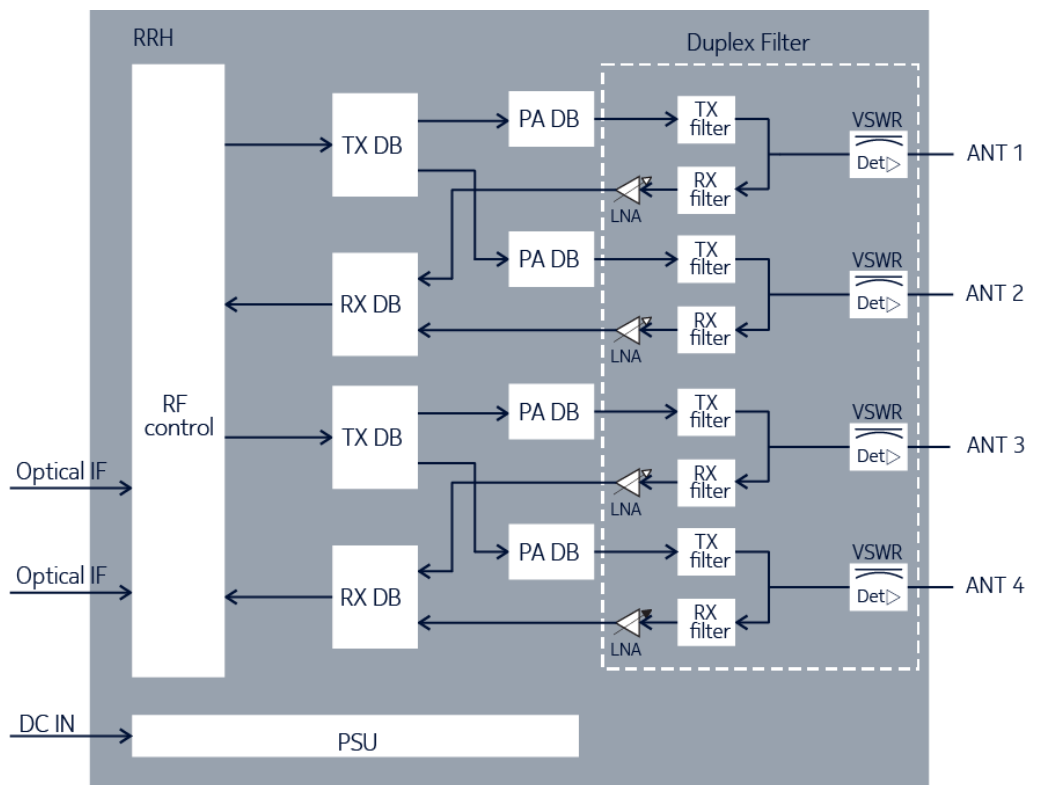

Electrical specifications

Table 444 AHEJ electrical specifications

Property	Value
Nominal supply voltage	-48.0 V DC
Nominal input voltage range	-40.5 V DC to -57.0 V DC
Extended input voltage range	-36 V to -40.5 V and -57 V to -60 V (DC)



Note: The minimum startup voltage is -40.5 V DC. If the input voltage is below/beyond extended limits, the unit might shut down.

Power consumption

Typical power consumption [W] for 48VDC input, at 25°C, representative of typical product performance under the same conditions (HW variant, SW version, configuration, environment, and so on) with +/- 10% margin. Average = (6h low hour load, 10h medium hour load and 8h busy hour load) / 24h

Configurations explained on examples:

- GSM/WCDMA: 2/2/2 = three sectors, two carriers/TRXs per sector
- LTE:
 - o 2/2/2 2Tx = three sectors, two carriers per sector, 2Tx per carrier
 - o 1+1/1+1/1+1 4Tx = three dual-band sectors, one carrier per sector per band, 4Tx per carrier

Some radio units are capable of providing only one sector coverage. Then the power values in the table consider deployment of three radio units.

Table 445 AHEJ power consumption in LTE mode

Configuration	Output power per carrier [W]	Power consumption ETSI 202706 average $P_{RRH, static}$	Power consumption ETSI 202706 busy hour load $P_{BH, RRH, static}$	Power consumption 100% RF power load $P_{100\% RRH}$
1 sector 2Tx	2x5	70	76	89
1 sector 4Tx	4x5	95	109	136



Note: Power consumption in 5G mode will be provided in a future release.

Power reduction



Note: The maximum power reduction (dlCellPwrRed) value is 20 dB. High power reduction values may cause radio outages.

Related optional items

- APAB AirScale Micro AC PSU (474130A)
- OCTIS Plug Kit AC Power (474244A)
- OCTIS Plug Kit DC Power (474184A)
- OCTIS Plug Kit SFP (474183A)

- AMBA AirScale Micro Bracket Assembly Kit (474182A)
- AAFA AirScale Micro Integrated Antenna (474185A)
- AMBC AirScale Micro Tilt Mount Kit (474332A)
- AMBK AirScale Micro Horizontal Strand Mount Bracket (474630A)
- AMBL AirScale Micro Horizontal Strand Mount Bracket (474849A)
- FMWG AirScale Micro Wall/Pole Mount Kit for Single Radio (474013A)
- FMWH AirScale Micro Wall/Pole Mount Kit for Dual Radios (474312A)
- FMWM AirScale Micro RRH Enclosure (474431A)

Installation options

- Pole/wall installation
- Bookshelf mounting
- Tilt mounting
- Enclosure mounting
- Strand mounting



NOTICE: Always install this RRH in a vertical orientation with connectors on the bottom side, to ensure convection cooling.

Dimensions and weight

Table 446 AHEJ dimensions and weight

Property	Value	Dimensions orientation
Height	295 mm (11.6 in.)	
Depth	55 mm (2.2 in.)	
Width	245 mm (9.6 in.)	
Weight	5.4 kg (11.7 lb) core unit (DC version) 6.1 kg (13.4 lb) with AC adapter (AC version)	

Environmental specifications

Table 447 AHEJ environmental specifications

Property	Value
Maximum operational outdoor temperature (in the shade)	55°C (131°F)
Maximum operational outdoor temperature (in the sun)	45°C (113°F)
Maximum indoor temperature	45°C (113°F)
Minimum operational temperature (including cold start)	-35°C (-31°F)

Table 447 AHEJ environmental specifications (Cont.)

Property	Value
	Cold start from -40°C (-40°F)
IP rating	IP65

Feature interdependencies

The *LTE4270: Nokia AirScale Micro 4T4R B3 20 W (AHEJ)* feature is impacted by the following features:

- *LTE112: Cell Bandwidth - 20 MHz* enables LTE 20 MHz carriers.
- *LTE113: Cell Bandwidth - 15 MHz* enables LTE 15 MHz carriers.
- *LTE114: Cell Bandwidth - 10 MHz* enables LTE 10 MHz carriers.
- *LTE115: Cell Bandwidth - 5 MHz* enables LTE 5 MHz carriers.
- *LTE116: Cell Bandwidth - 3 MHz* enables LTE 3 MHz carriers.
- *LTE117: Cell Bandwidth - 1.4 MHz* enables LTE 1.4 MHz carriers.
- With *LTE614: Distributed Site*, AHEJ can be used in distributed sites with up to 23 km fiber length to the system module.
- *LTE1103: Load based Power Saving for multilayer networks*
- *LTE1203: Load based Power Saving mode with TX power reduction or path switching off*
- *LTE2508: BTS Embedded Power Meter for Energy Efficiency Monitoring*
- With *LTE2541: Nokia CPRI RRH/RFM chaining*, AHEJ supports Nokia CPRI chain of up to 4 radio units.
- *LTE3036: Micro DTX extension*

6.6 Nokia AirScale Micro 4T4R B5 20 W (AHCE)

AHCE is introduced by *LTE3654/5GC001486: Nokia AirScale Micro 4T4R B5 20 W (AHCE)*.

Functional description

Table 448 AHCE functional specification

Property	Value
Output power	4x5 W
QAM	256 QAM (DL) 64 QAM (UL)
Number of TXRX	4T4R
Outdoor installation	Yes
Supported technologies (standalone and MSR)	FDD-LTE, 5G
IoT support	NB-IoT in band, guard band (GB), standalone (SA)

Table 448 AHCE functional specification (Cont.)

Property	Value
TX frequency range	869–894 MHz
RX frequency range	824–849 MHz
DL filter bandwidth	25 MHz
UL filter bandwidth	25 MHz
iBW (instantaneous bandwidth)	25 MHz
oBW (occupied bandwidth)	25 MHz
Number of carriers per pipe	Up to 4
Supported bandwidths	LTE: 1.4, 3, 5, 10 MHz including NB-IoT (in band and GB) 5G: 5, 10, 15, 20 MHz

Interfaces

Figure 123 AHCE interfaces

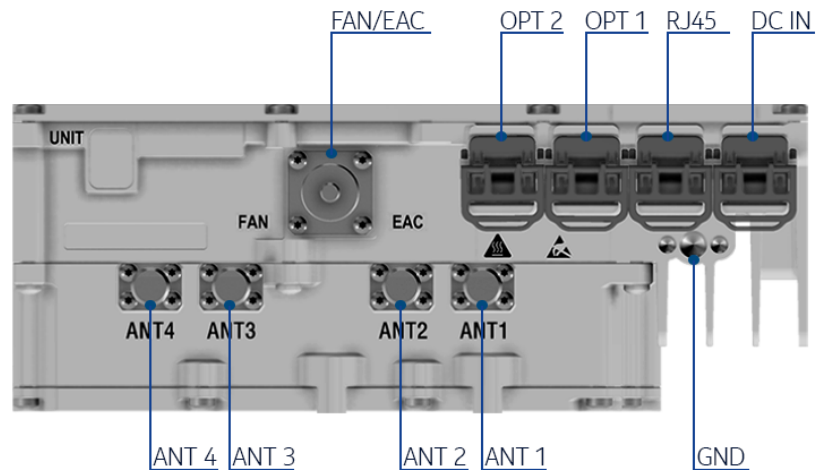



Table 449 AHCE interfaces

Interface	Label on the HW	Number of interfaces	Connector type	Additional info
Power Connector	DC IN	1	OCTIS Plug Kit	Hot insert not supported
Antenna connector	ANT	4	NEX 10	-
External Alarm Connection	FAN/EAC	1	CIRC 8F IP67 Flange	-

Table 449 AHCE interfaces (Cont.)

Interface	Label on the HW	Number of interfaces	Connector type	Additional info
Optical interface	OPT	2	OCTIS Plug Kit SFP/SFP+	9.8 Gbps, CPRI
Ethernet	RJ	1	RJ45	Separate feature required to enable this interface
Grounding		1	M8 or dual M5 screws	-



WARNING! Risk of electric shock

Before turning RF power on, RF ports have to be terminated by nominal 50 Ω load (for example, feeder with antenna). However, if these conditions are not met, the plastic caps that are delivered within the unused RF ports should remain in place. The plastic caps isolate RF port from the environment, and thus provide electric shock security in case RF power is accidentally on.

Antenna Line Devices (ALDs) support



Note: There is no Antenna Line Device support for AHCE.

Functional block diagram

Figure 124 AHCE functional block diagram

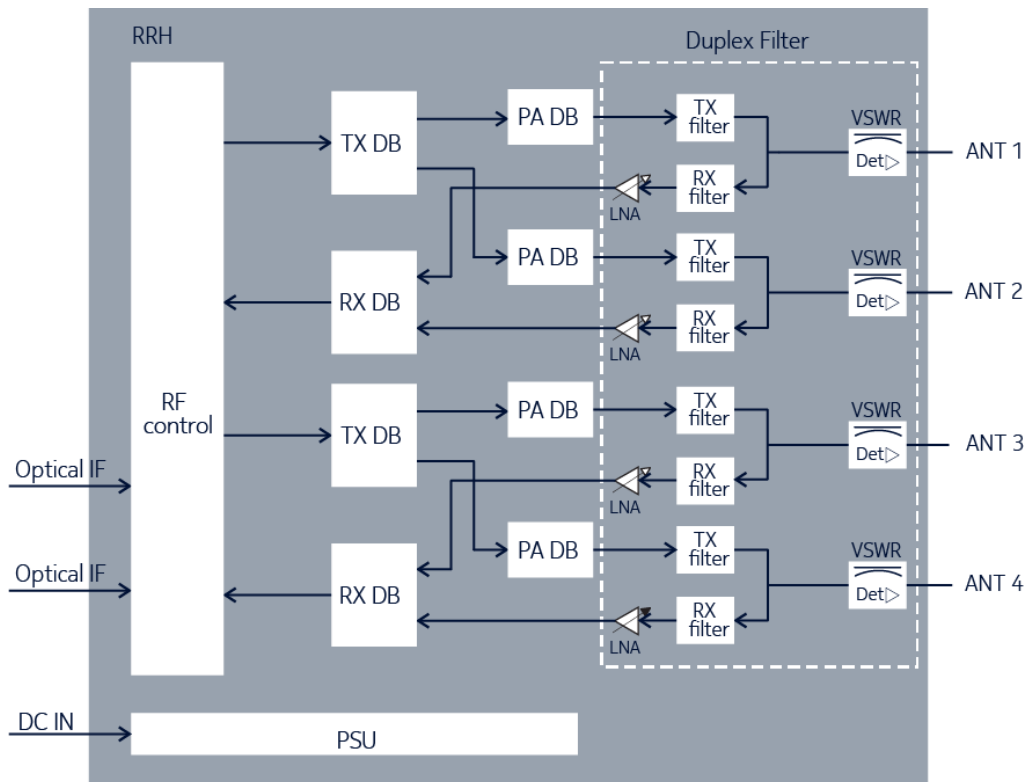

Electrical specifications

Table 450 AHCE electrical specifications

Property	Value
Nominal supply voltage	-48.0 V DC
Nominal input voltage range	-40.5 V DC to -57.0 V DC
Extended input voltage range	-36 V to -40.5 V and -57 V to -60 V (DC)



Note: The minimum startup voltage is -40.5 V DC. If the input voltage is below/beyond extended limits, the unit might shut down.

Power consumption



Note: AHCE power consumption will be provided in future releases.

Power reduction



Note: The maximum power reduction (dlCellPwrRed) value is 20 dB. High power reduction values may cause radio outages.

Related optional items

- APAB AirScale Micro AC PSU (474130A)
- OCTIS Plug Kit AC Power (474244A)
- OCTIS Plug Kit DC Power (474184A)
- OCTIS Plug Kit SFP (474183A)
- AMBA AirScale Micro Bracket Assembly Kit (474182A)
- AACA AirScale Micro Integrated Antenna (474227A)
- AMBC AirScale Micro Tilt Mount Kit (474332A)
- AMBK AirScale Micro Horizontal Strand Mount Bracket (474630A)
- AMBL AirScale Micro Horizontal Strand Mount Bracket (474849A)
- FMWG AirScale Micro Wall/Pole Mount Kit for Single Radio (474013A)
- FMWH AirScale Micro Wall/Pole Mount Kit for Dual Radios (474312A)

Installation options

- Pole/wall installation
- Bookshelf mounting
- Strand mounting
- Enclosure mounting



NOTICE: Always install this RRH in a vertical orientation with connectors on the bottom side, to ensure convection cooling.

Dimensions and weight

Table 451 AHCE dimensions and weight

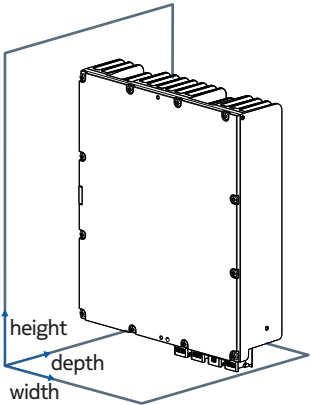
Property	Value	Dimensions orientation
Height	295 mm (11.6 in.)	
Depth	95 mm (3.74 in.)	
Width	245 mm (9.55 in.)	
Weight	8.0 kg (17.6 lb) core unit (DC version) 8.7 kg (19.2 lb) with AC adapter (AC version)	

Environmental specifications

Table 452 AHCE environmental specifications

Property	Value
Maximum operational outdoor temperature (in the shade)	55°C (131°F)
Maximum operational outdoor temperature (in the sun)	55°C (131°F)
Maximum indoor temperature	45°C (113°F)
Minimum operational temperature	-40°C (-40°F)
IP rating	IP65

Feature interdependencies

The *LTE3654: Nokia AirScale Micro 4T4R B5 20W (AHCE)* feature is impacted by the following features:

- *LTE114: Cell Bandwidth - 10 MHz* enables LTE 10 MHz carriers.
- *LTE115: Cell Bandwidth - 5 MHz* enables LTE 5 MHz carriers.
- *LTE116: Cell Bandwidth - 3 MHz* enables LTE 3 MHz carriers.
- *LTE117: Cell Bandwidth - 1.4 MHz* enables LTE 1.4 MHz carriers.
- With *LTE614: Distributed Site*, AHCE can be used in distributed sites with up to 23km fiber length to the system module.
- *LTE1103: Load based Power Saving for multilayer networks*
- *LTE1203: Load based Power Saving mode with TX power reduction or path switching off*
- *LTE2508: BTS Embedded Power Meter for Energy Efficiency Monitoring*
- With *LTE2541: Nokia CPRI RRH/RFM chaining*, AHCE supports Nokia CPRI chain of up to 4 radio units.
- *LTE3036: Micro DTX extension*

6.7 Nokia AirScale Micro 4T4R B7 20 W (AHHA)

AHHA is introduced by LTE3713/5GC001483: Nokia AirScale Micro 4T4R B7 20 W (AHHA).

Functional description

Table 453 AHHA functional specification

Property	Value
Output power	4 x 5 W
QAM	256 QAM
Number of TXRX	4T4R
Outdoor installation	Yes
Supported technologies (standalone and MSR)	FDD-LTE, 5G
TX frequency range	2620–2690 MHz
RX frequency range	2500–2570 MHz
DL filter bandwidth	70 MHz
UL filter bandwidth	70 MHz
iBW (instantaneous bandwidth)	70 MHz
oBW (occupied bandwidth)	70 MHz
Number of carriers per pipe	Up to 4
Supported bandwidths	LTE: 5, 10, 15, 20 MHz 5G: 20 MHz

Interfaces

Figure 125 AHHA interfaces

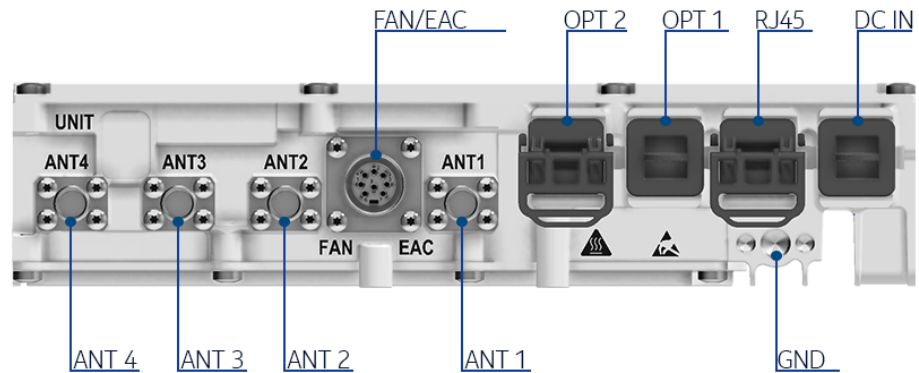



Table 454 AHHA interfaces

Interface	Label on the HW	Number of interfaces	Connector type	Additional info
Power Connector	DC IN	1	DC Octis Plug Kit	-
Antenna connector	ANT	4	Nex10	-
External Alarm Connection/Fan	FAN/EAC	1	CIRC 8F IP67 Flange	-
Optical interface	OPT	2	OCTIS Plug Kit SFP/SFP+	9.8 Gbps, CPRI
Grounding		1	M8 or dual M5 screws	-



WARNING! Risk of electric shock

Before turning RF power on, RF ports have to be terminated by nominal 50 Ω load (for example, feeder with antenna). However, if these conditions are not met, the plastic caps that are delivered within the unused RF ports should remain in place. The plastic caps isolate RF port from the environment, and thus provide electric shock security in case RF power is accidentally on.

Antenna Line Devices (ALDs) support



Note: There is no Antenna Line Device support for AHHA

Functional block diagram

Figure 126 AHHA functional block diagram

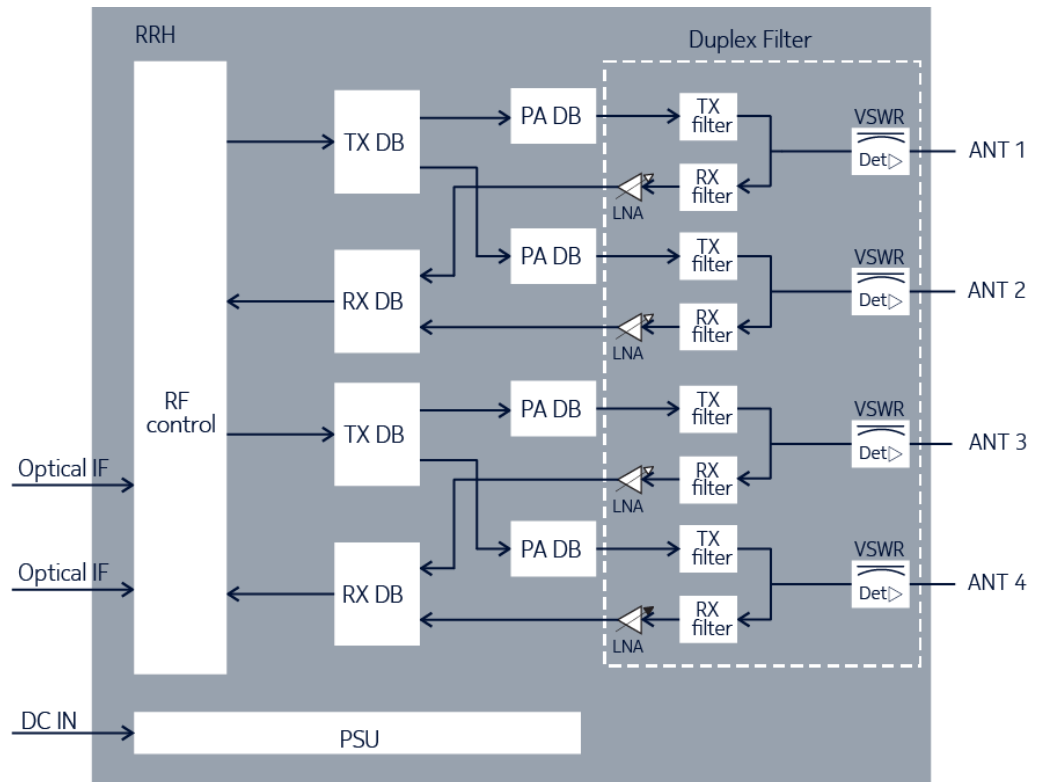

Electrical specifications

Table 455 AHHA electrical specifications

Property	Value
Nominal supply voltage	-48.0 V DC
Nominal input voltage range	-40.5 V DC to -57.0 V DC
Extended input voltage range	-36 V to -40.5 V and -57 V to -60 V (DC)

Note: The minimum startup voltage is -40.5 V DC. If the input voltage is below/beyond extended limits, the unit might shut down.

Power consumption

Note: AHHA power consumption will be provided in future releases.

Power reduction

Note: The maximum power reduction (dlCellPwrRed) value is 20 dB. High power reduction values may cause radio outages.

Related optional items

- APAE AirScale Micro AC PSU (474518A)
- OCTIS Plug Kit AC Power (474244A)
- OCTIS Plug Kit DC Power (474184A)

- OCTIS Plug Kit SFP (474183A)
- AMBA AirScale Micro Bracket Assembly Kit (474182A)
- AAHG AirScale Micro Integrated Antenna (474584A)
- AMBC AirScale Micro Tilt Mount Kit (474332A)
- AMBK AirScale Micro Horizontal Strand Mount Bracket (474630A)
- AMBL AirScale Micro Horizontal Strand Mount Bracket (474849A)
- FMWG AirScale Micro Wall/Pole Mount Kit for Single Radio (474013A)
- FMWH AirScale Micro Wall/Pole Mount Kit for Dual Radios (474312A)
- FMWM AirScale Micro RRH Enclosure (474431A)

Installation options

- Pole/wall installation
- Bookshelf mounting
- Enclosure mounting
- Strand mounting



NOTICE: Always install this RRH in a vertical orientation with connectors on the bottom side, to ensure convection cooling.

Dimensions and weight

Table 456 AHHA dimensions and weight

Property	Value	Dimensions orientation
Height	295 mm (11.1 in.)	
Depth	65 mm (2.6 in.) core unit (DC version) 65 mm (2.6 in.) with AC adapter (AC version)	
Width	245 mm (9.6 in) core unit (DC version) 270 mm (10.6 in.) with AC adapter (AC version)	
Weight	max. 5.0 kg (11.0 lb) core unit (DC version) 5.8 kg (12.8 lb) with AC adapter (AC version)	

Environmental specifications

Table 457 AHHA environmental specifications

Property	Value
Maximum operational outdoor temperature (in the shade)	55°C (131°F)

Table 457 AHHA environmental specifications (Cont.)

Property	Value
Maximum operational outdoor temperature (in the sun)	55°C (131°F)
Maximum indoor temperature	45°C (113°F)
Minimum operational temperature	-40°C (-40°F)
IP rating	IP65

Feature interdependencies

LTE3713: AirScale Micro 4T4R B7 20 W (AHHA) supports the following features:

- *LTE 112: Cell Bandwidth - 20 MHz* enables 20 MHz carriers.
- *LTE 113: Cell Bandwidth - 15 MHz* enables LTE 15 MHz carriers.
- *LTE 114: Cell Bandwidth - 10 MHz* enables LTE 10 MHz carriers.
- *LTE 115: Cell Bandwidth - 5 MHz* enables LTE 5 MHz carriers.
- With *LTE 614: Distributed Site* , AHHA can be used in distributed sites with up to 23 km fiber length to the system module.
- Power saving features:
 - *LTE1103: Load based Power Saving for multi-layer networks*
 - *LTE1203: Load based Power Saving with Tx path switching off*
 - *LTE2508: BTS Embedded Power Meter for Energy Efficiency Monitoring*
 - *LTE3036: Micro DTX extension*

6.8 Nokia AirScale Micro 4T4R B13 20 W (AHBB)

AHBB is introduced by LTE3655: Nokia AirScale Micro 4T4R B13 20 W (AHBB).

Functional description

Table 458 AHBB functional specification

Property	Value
Output power	4x5 W
QAM	256 QAM (DL) 64 QAM (UL)
Number of TXRX	4T4R
Outdoor installation	Yes
Supported technologies (standalone and MSR)	FDD-LTE, 5G-ready
IoT support	NB-IoT in band, guard band (GB)
TX frequency range	746 - 756 MHz
RX frequency range	777 - 787 MHz

Table 458 AHBB functional specification (Cont.)

Property	Value
DL filter bandwidth	10 MHz
UL filter bandwidth	10 MHz
iBW (instantaneous bandwidth)	10 MHz
oBW (occupied bandwidth)	10 MHz
Number of carriers per pipe	Up to 4
Supported bandwidths	5, 10 MHz including NB-IoT (in band and GB)

Interfaces

Figure 127 AHBB interfaces

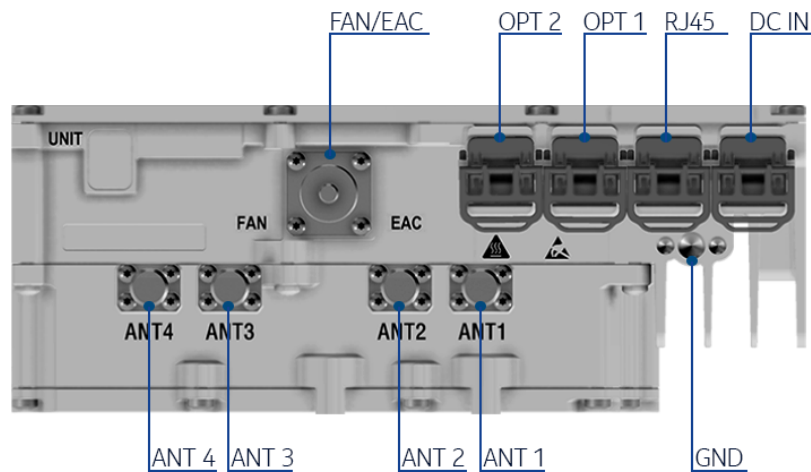



Table 459 AHBB interfaces

Interface	Label on the HW	Number of interfaces	Connector type	Additional info
Power Connector	DC IN	1	DC Octis Plug Kit	Hot insert not supported
Antenna connector	ANT	4	NEX 10	-
External Alarm Connection/Fan	EAC/FAN	1	CIRC 8F IP67 Flange	-
Optical interface	OPT	2	OCTIS Plug Kit SFP/SFP+	9.8 Gbps, CPRI
Ethernet	RJ	1	RJ45	Separate feature required to

Table 459 AHBB interfaces (Cont.)

Interface	Label on the HW	Number of interfaces	Connector type	Additional info
				enable this interface
Grounding		1	M8 or dual M5 screws	-



WARNING! Risk of electric shock

Before turning RF power on, RF ports have to be terminated by nominal 50 Ω load (for example, feeder with antenna). However, if these conditions are not met, the plastic caps that are delivered within the unused RF ports should remain in place. The plastic caps isolate RF port from the environment, and thus provide electric shock security in case RF power is accidentally on.

Antenna Line Devices (ALDs) support



Note: There is no Antenna Line Device support for AHBB.

Functional block diagram

Figure 128 AHBB functional block diagram

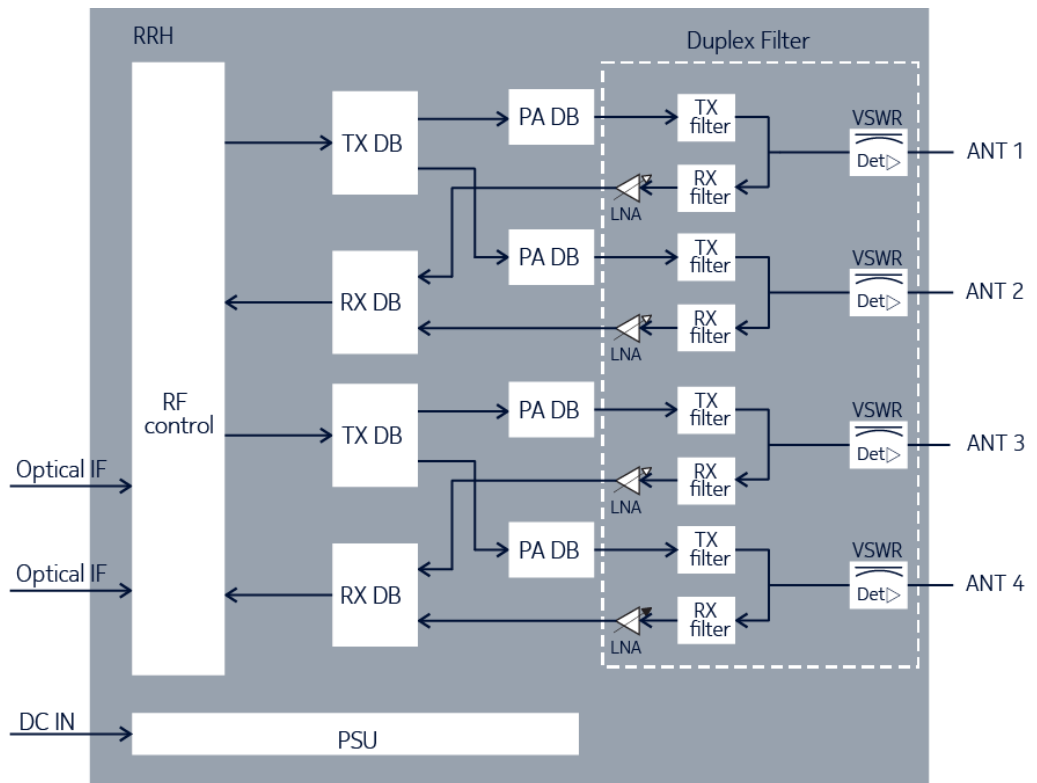

Electrical specifications

Table 460 AHBB electrical specifications

Property	Value
Nominal supply voltage	-48.0 V DC
Nominal input voltage range	-40.5 V DC to -57.0 V DC
Extended input voltage range	-36 V to -40.5 V and -57 V to -60 V (DC)



Note: The minimum startup voltage is -40.5 V DC. If the input voltage is below/beyond extended limits, the unit might shut down.

Power consumption



Note: AHBB power consumption will be provided in further releases.

Power reduction



Note: The maximum power reduction (dlCellPwrRed) value is 20 dB. High power reduction values may cause radio outages.

Related optional items

- APAB AirScale Micro AC PSU (474130A)
- OCTIS Plug Kit AC Power (474244A)
- OCTIS Plug Kit DC Power (474184A)
- OCTIS Plug Kit SFP (474183A)
- AMBA AirScale Micro Bracket Assembly Kit (474182A)
- AABA AirScale Micro Integrated Antenna (474230A)
- AMBC AirScale Micro Tilt Mount Kit (474332A)
- AMBK AirScale Micro Horizontal Strand Mount Bracket (474630A)
- AMBL AirScale Micro Horizontal Strand Mount Bracket (474849A)
- FMWG AirScale Micro Wall/Pole Mount Kit for Single Radio (474013A)
- FMWH AirScale Micro Wall/Pole Mount Kit for Dual Radios (474312A)

Installation options

- Pole/wall installation
- Bookshelf mounting
- Tilt mounting
- Enclosure mounting
- Strand mounting



NOTICE: Always install this RRH in a vertical orientation with connectors on the bottom side, to ensure convection cooling.

Dimensions and weight

Table 461 AHBB dimensions and weight

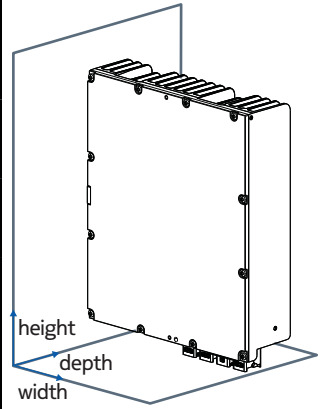
Property	Value	Dimensions orientation
Height	295 mm (11.6 in.)	
Depth	95 mm (3.74 in.)	
Width	245 mm (9.6 in.)	
Weight	7.8 kg (17.2 lb) core unit (DC version) 8.5 kg (18.7 lb) with AC adapter (AC version)	

Environmental specifications

Table 462 AHBB environmental specifications

Property	Value
Maximum operational outdoor temperature (in the shade)	55°C (131°F)
Maximum operational outdoor temperature (in the sun)	45°C (113°F)
Maximum indoor temperature	45°C (113°F)
Minimum operational temperature (including cold start)	-35°C (-31°F) Cold start from -40°C (-40°F)
IP rating	IP65

LTE3655 feature interdependencies

LTE3655: Nokia AirScale Micro 4T4R B13 20 W (AHBB) supports the following features:

- *LTE114: Cell Bandwidth - 10 MHz* enables LTE 10 MHz carriers.
- *LTE115: Cell Bandwidth - 5 MHz* enables LTE 5 MHz carriers.
- With *LTE614: Distributed Site*, AHBB can be used in distributed sites with up to 23km fiber length to the system module.
- *LTE1103: Load based Power Saving for multilayer networks*
- *LTE1203: Load based Power Saving mode with TX power reduction or path switching off*
- *LTE2428: Nokia CPRI in FDD-LTE* enables to provide support for CPRI interface.
- *LTE2508: BTS Embedded Power Meter for Energy Efficiency Monitoring*
- With *LTE2541: Nokia CPRI RRH/RFM chaining*, AHBB supports Nokia CPRI chain of up to 4 radio units.
- *LTE3036: Micro DTX extension*

6.9 Nokia AirScale Micro 4T4R B14 20 W (AHBC)

AHBC is introduced by LTE5006: Nokia AirScale Micro RRH 4T4R B14 20 W (AHBC).

Functional description

Table 463 AHBC functional specification

Property	Value
Output power	4x5 W
QAM	256 QAM (DL) 64 QAM (UL)
Number of TXRX	4T4R
Outdoor installation	Yes
Supported technologies (standalone and MSR)	FDD-LTE, 5G-ready
TX frequency range	758 - 768 MHz
RX frequency range	788 - 798 MHz
DL filter bandwidth	10 MHz
UL filter bandwidth	10 MHz
iBW (instantaneous bandwidth)	10 MHz
oBW (occupied bandwidth)	10 MHz
Number of carriers per pipe	Up to 2
Supported bandwidths	5, 10 MHz

Interfaces

Figure 129 AHBC interfaces

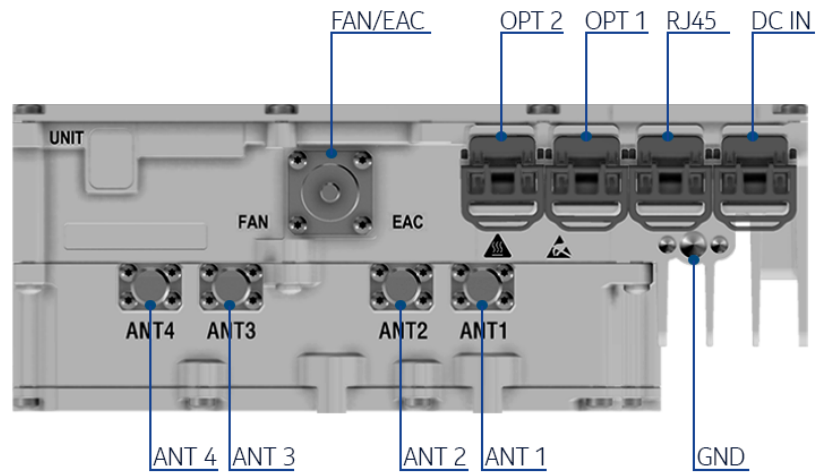

Table 464 AHBC interfaces

Interface	Label on the HW	Number of interfaces	Connector type	Additional info
Power Connector	DC IN	1	DC OCTIS Plug Kit	Hot insert not supported
Antenna connector	ANT	4	NEX 10	-
External Alarm Connection/Fan	EAC/FAN	1	CIRC 8F IP67 Flange	-
Optical interface	OPT	2	OCTIS Plug Kit SFP/SFP+	9.8 Gbps, CPRI
Ethernet	RJ	1	RJ45	-
Grounding		1	M8 or two M5 screws	-



WARNING! Risk of electric shock

Before turning RF power on, RF ports have to be terminated by nominal 50 Ω load (for example, feeder with antenna). However, if these conditions are not met, the plastic caps that are delivered within the unused RF ports should remain in place. The plastic caps isolate RF port from the environment, and thus provide electric shock security in case RF power is accidentally on.

Antenna Line Devices (ALDs) support



Note: There is no Antenna Line Device support for AHBC.

Functional block diagram

Figure 130 AHBC functional block diagram

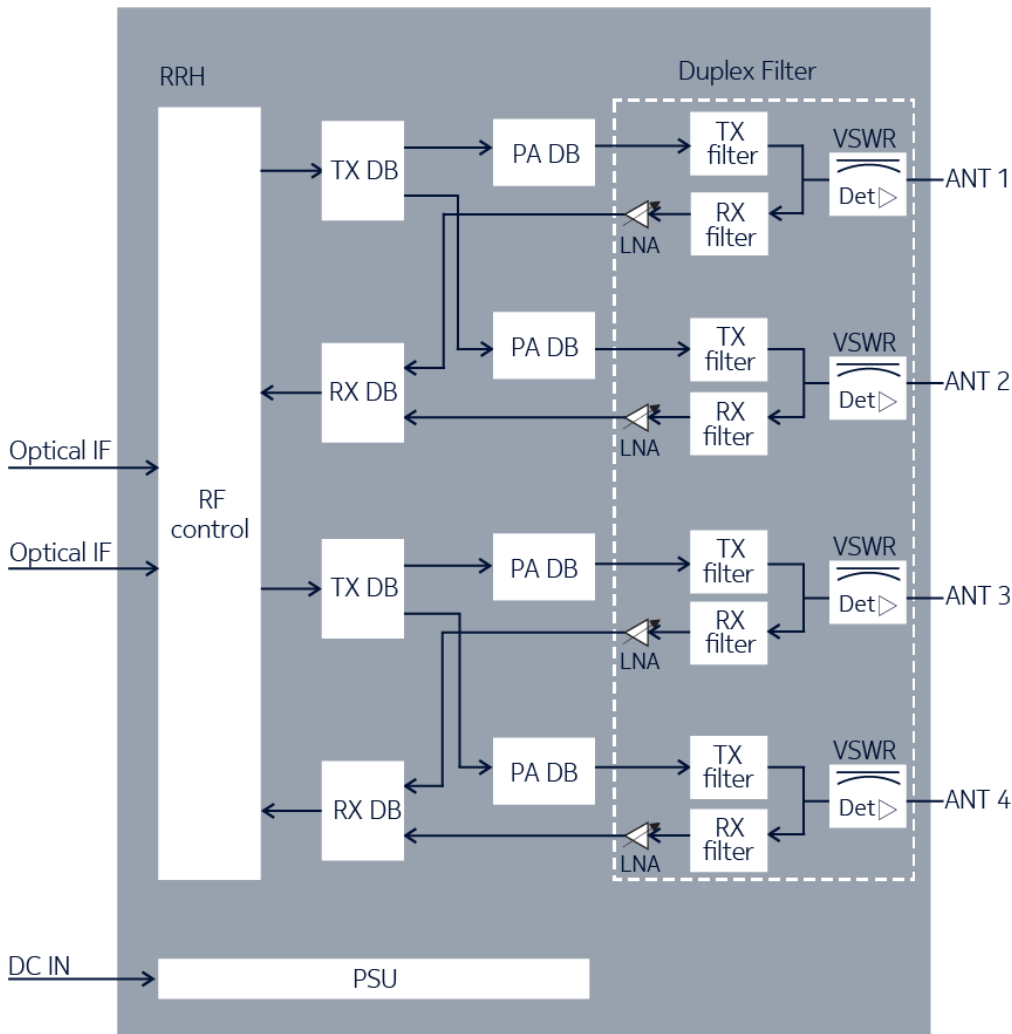

Electrical specifications

Table 465 AHBC electrical specifications

Property	Value
Nominal supply voltage	DC: -48 V
Nominal input voltage range	DC: -40.5 V to -57 V AC: 80 V to 288 V (through external AC/DC converter)
Extended input voltage range	DC: -36 V to -40.5 V DC: -57 V to -60 V



Note: The minimum startup voltage is -40.5 V DC. If the input voltage is below/beyond extended limits, the unit might shut down.

Power consumption

i **Note:** AHBC power consumption will be provided in further releases.

Power reduction

i **Note:** The maximum power reduction (`dlCellPwrRed`) value is 20 dB. High power reduction values may cause radio outages.

Related optional items

- OCTIS Plug Kit AC Power (474244A)
- OCTIS Plug Kit DC Power (474184A)
- OCTIS Plug Kit SFP (474183A)
- APAB AirScale Micro AC PSU (474130A)
- AABA AirScale Micro Integrated Antenna (474230A)
- AMBA AirScale Micro Bracket Assembly Kit (474182A)
- AMBC AirScale Micro Tilt Mount Kit (474332A)
- AMBK AirScale Micro Horizontal Strand Mount Bracket (474630A)
- AMBL AirScale Micro Horizontal Strand Mount Bracket (474849A)
- FMWG AirScale Micro Wall/Pole Mount Kit for Single Radio (474013A)
- FMWH AirScale Micro Wall/Pole Mount Kit for Dual Radios (474312A)

Installation options

- Pole/wall
- Bookshelf mounting
- Tilt mounting
- Enclosure mounting
- Strand mounting

! **NOTICE:** Always install this RRH in a vertical orientation with connectors on the bottom side, to ensure convection cooling.

Dimensions and weight

Table 466 AHBC dimensions and weight

Property	Value	Dimensions orientation
Height	295 mm (11.61 in.)	
Depth	95 mm (3.74 in.)	
Width	245 mm (9.65 in.) core unit (DC version) 270 mm (10.63 in.) with AC adapter (AC version)	
Weight	8.1 kg (17.9 lb) core unit (DC version) 8.8 kg (19.4 lb) with AC adapter (AC version)	

Environmental specifications

Table 467 AHBC environmental specifications

Property	Value
Maximum operational outdoor temperature (in the shade)	55°C (131°F)
Maximum operational outdoor temperature (in the sun)	45°C (113°F)
Maximum indoor temperature	45°C (113°F)
Minimum operational temperature (including cold start)	-35°C (-31°F) Cold start from -40°C (-40°F)
IP rating	IP65

LTE5006 feature interdependencies

The *LTE5006: Nokia AirScale Micro 4T4R B14 20 W (AHBC)* feature is impacted by the following features:

- *LTE114: Cell Bandwidth - 10 MHz* enables LTE 10 MHz carriers.
- *LTE115: Cell Bandwidth - 5 MHz* enables LTE 5 MHz carriers.
- With *LTE614: Distributed Site*, AHBC can be used in distributed sites with up to 23 km (14.29 mi) fiber length to the system module.
- *LTE1103: Load based Power Saving for multilayer networks* and *LTE1203: Load based Power Saving mode with TX power reduction or path switching off* need to be enabled to use PA shutdown feature.
- *LTE2428: Nokia CPRI in FDD-LTE* provides support for CPRI interface.
- *LTE2508: BTS Embedded Power Meter for Energy Efficiency Monitoring* provides energy-monitoring software support for radio frequency (RF) modules.
- With *LTE2541: Nokia CPRI RRH/RFM chaining*, AHBC supports Nokia CPRI chain of up to four radio units.
- *LTE3036: Micro DTX extension* provides energy saving of the eNB.

6.10 Nokia AirScale Micro 4T4R B25 20 W (AHFB)

AHFB is introduced by LTE3429/SR001996/5GC001154: Nokia AirScale Micro 4T4R B25 20 W (AHFB).

Functional description

Table 468 AHFB functional specification

Property	Value
Output power	4x5 W
QAM	256QAM (DL); 64 QAM (UL)
Number of TXRX	4T4R

Table 468 AHFB functional specification (Cont.)

Property	Value
Outdoor installation	Yes
Supported technologies (standalone and MSR)	WCDMA, FDD-LTE, WCDMA-LTE*, 5G
TX frequency range	1930–1995 MHz
RX frequency range	1850–1915 MHz
DL filter bandwidth	65 MHz
UL filter bandwidth	65 MHz
iBW (instantaneous bandwidth)	65 MHz
oBW (occupied bandwidth)	65 MHz
Supported bandwidths	LTE: 1.4, 3, 5, 10, 15, 20 MHz WCDMA: 5 MHz 5G: 20 MHz
Number of carriers per pipe	Up to 4

*WCDMA and LTE can be transmitted simultaneously with any number of carriers, but the combined bandwidth cannot exceed 55 MHz.

Interfaces

Figure 131 AHFB interfaces

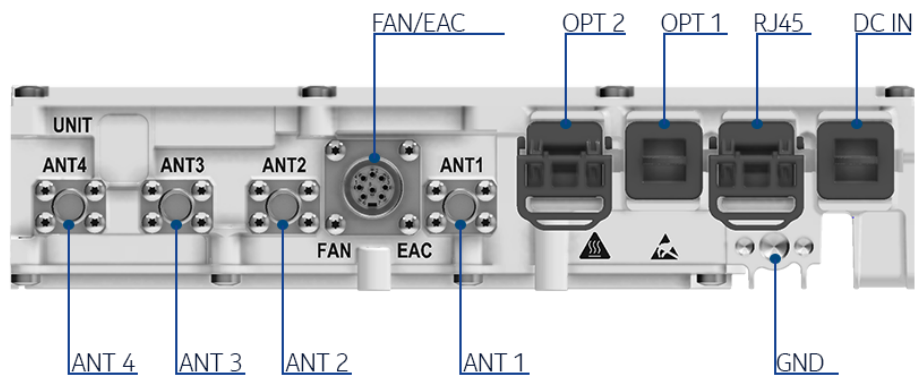



Table 469 AHFB interfaces

Interface	Label on the HW	Number of interfaces	Connector type	Additional info
Power Connector	DC IN	1	OCTIS Plug Kit	Hot insert not supported
Antenna connector	ANT	4	NEX 10	-
External Alarm Connection/Fan	FAN/EAC	1	CIRC 8F IP67 Flange	Hot insert not supported
Optical interface	OPT	2	OCTIS Plug Kit SFP/SFP+	9.8 Gbps, CPRI
Ethernet	RJ	1	RJ45	Separate feature required to enable this interface
Ground		1	M8 or dual M5 screws	-



WARNING! Risk of electric shock

Before turning RF power on, RF ports have to be terminated by nominal 50 Ω load (for example, feeder with antenna). However, if these conditions are not met, the plastic caps that are delivered within the unused RF ports should remain in place. The plastic caps isolate RF port from the environment, and thus provide electric shock security in case RF power is accidentally on.

Antenna Line Devices (ALDs) support



Note: There is no Antenna Line Device support for AHFB.

Functional block diagram

Figure 132 AHFB functional block diagram

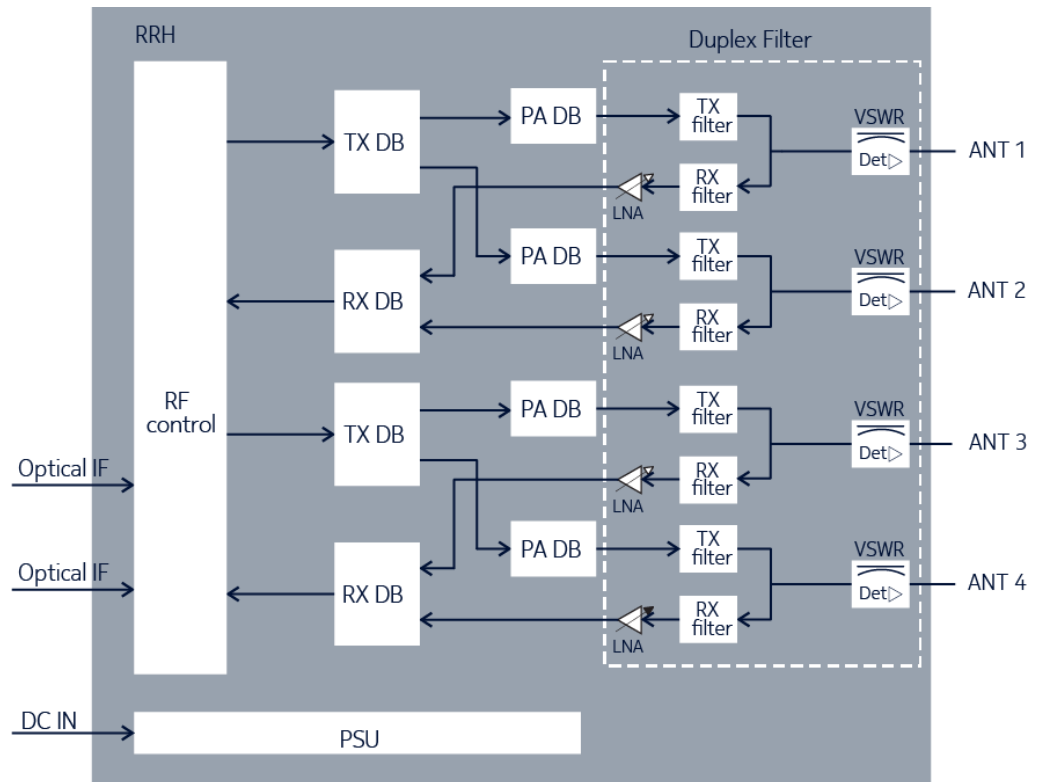

Electrical specifications

Table 470 AHFB electrical specifications

Property	Value
Nominal supply voltage	-48.0 V DC
Nominal input voltage range	-40.5 V DC to -57.0 V DC
Extended input voltage range	-36 V to -40.5 V and -57 V to -60 V (DC)



Note: The minimum startup voltage is -40.5 V DC. If the input voltage is below/beyond extended limits, the unit might shut down.

Power consumption

Typical power consumption [W] for 48VDC input, at 25°C, representative of typical product performance under the same conditions (HW variant, SW version, configuration, environment, and so on) with +/- 10% margin. Average = (6h low hour load, 10h medium hour load and 8h busy hour load) / 24h

Configurations explained on examples:

- GSM/WCDMA: 2/2/2 = three sectors, two carriers/TRXs per sector
- LTE:
 - o 2/2/2 2Tx = three sectors, two carriers per sector, 2Tx per carrier
 - o 1+1/1+1/1+1 4Tx = three dual-band sectors, one carrier per sector per band, 4Tx per carrier

Some radio units are capable of providing only one sector coverage. Then the power values in the table consider deployment of three radio units.

Table 471 AHFB power consumption in LTE mode

Configuration	Output power per carrier [W]	Power consumption ETSI 202706 average $P_{RRH, static}$	Power consumption ETSI 202706 busy hour load $P_{BH, RRH, static}$	Power consumption 100% RF power load $P_{100\% RRH}$
1 sector 2Tx	2x5	68	75	89
1 sector 4Tx	4x5	92	106	135



Note: Power consumption in 5G mode will be provided in a future release.

Power reduction



Note: The maximum power reduction ($dlCellPwrRed$) value is 20 dB. High power reduction values may cause radio outages.

Related optional items

- APAB AirScale Micro AC PSU (474130A)
- OCTIS Plug Kit AC Power (474244A)
- OCTIS Plug Kit DC Power (474184A)
- OCTIS Plug Kit SFP (474183A)
- AMBA AirScale Micro Bracket Assembly Kit (474182A)
- AAFA AirScale Micro Integrated Antenna (474185A)
- AMBC AirScale Micro Tilt Mount Kit (474332A)
- AMBK AirScale Micro Horizontal Strand Mount Bracket (474630A)
- AMBL AirScale Micro Horizontal Strand Mount Bracket (474849A)
- FMWG AirScale Micro Wall/Pole Mount Kit for Single Radio (474013A)
- FMWH AirScale Micro Wall/Pole Mount Kit for Dual Radios (474312A)
- FMWM AirScale Micro RRH Enclosure (474431A)
- FMWV AirScale Micro RRH Enclosure (475185A)

Installation options

- Pole
- Wall
- Enclosure
- Strand
- Bookshelf mounting
- Tilt mounting



NOTICE: Always install this RRH in a vertical orientation with connectors on the bottom side, to ensure convection cooling.

Dimensions and weight

Table 472 AHFB dimensions and weight

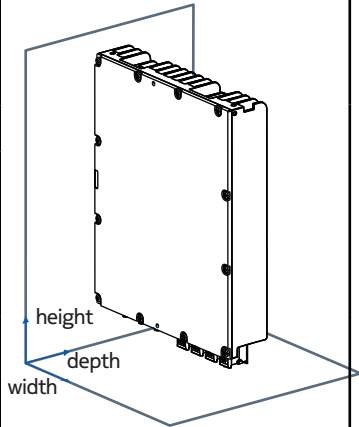
Property	Value	Dimensions orientation
Height	295 mm (11.61 in.)	
Depth	55 mm (2.17 in.)	
Width	245 mm (9.65 in.) core unit (DC version) 270 mm (10.63 in.) with AC adapter (AC version)	
Weight	5.4 kg (11.9 lb) core unit (DC version) 6.1 kg (13.4 lb) with AC adapter (AC version)	

Environmental specifications

Table 473 AHFB environmental specifications

Property	Value
Maximum operational outdoor temperature in the shade, assuming wind speed is 3 m/s (at constant high ambient temperature, maximum output power might be limited)	55°C (131°F)
Maximum operational outdoor temperature in the sun, assuming wind speed is 0.5 m/s (at constant high ambient temperature, maximum output power might be limited)	45°C (113°F)
Maximum indoor temperature	45°C (113°F)
Minimum operational temperature (including cold start)	-35°C (-31°F) Cold start from -40°C (-40°F)
IP rating	IP65

Feature interdependencies

The *LTE3429: Nokia AirScale Micro 4T4R B25 20 W (AHFB)* feature is impacted by the following features:

- *LTE112: Cell Bandwidth - 20 MHz* enables LTE 20 MHz carriers.
- *LTE113: Cell Bandwidth - 15 MHz* enables LTE 15 MHz carriers.
- *LTE114: Cell Bandwidth - 10 MHz* enables LTE 10 MHz carriers.
- *LTE115: Cell Bandwidth - 5 MHz* enables LTE 5 MHz carriers.
- *LTE116: Cell Bandwidth - 3 MHz* enables LTE 3 MHz carriers.
- *LTE117: Cell Bandwidth - 1.4 MHz* enables LTE 1.4 MHz carriers.

- With *LTE614: Distributed Site*, AHFB can be used in distributed sites with up to 23 km fiber length to the system module.
- *LTE1103: Load based Power Saving for multilayer networks* or *LTE1203: Load based Power Saving mode with TX power reduction or path switching off* need to be enabled to use PA shutdown feature.
- *LTE2508: BTS Embedded Power Meter for Energy Efficiency Monitoring* needs to be enabled to use energy metering feature.
- With *LTE2541: Nokia CPRI RRH/RFM chaining* , AHFB supports Nokia CPRI chain of up to four radio units.
- *LTE3036: Micro DTX extension*

6.11 Nokia AirScale Micro RRH 4T4R B41/n41 80 W (AWHHD)

AWHHD (475184A) is introduced by LTE5161/5GC001541: AirScale Micro RRH 4T4R B41/n41 80 W AWHHD.

Functional description

Table 474 AWHHD functional specification

Property	Value
Output power	4x20 W
Output power of the cell per TX	30 to 43 dBm
QAM	256 QAM (DL) 64 QAM (UL)
Number of TXRX	4T4R
Outdoor installation	Yes
Beamforming	No
Supported technologies (standalone and MSR)	TD-LTE, 5G
Frequency range	2515–2675 MHz
Filter bandwidth	160 MHz
iBW (instantaneous bandwidth)	160 MHz
oBW (occupied bandwidth)	160 MHz
Number of carriers per pipe	3 x LTE + 1 x 5G NR
Supported bandwidths	LTE: 20 MHz 5G: 100 MHz

Interfaces

Figure 133 AWHHD interfaces

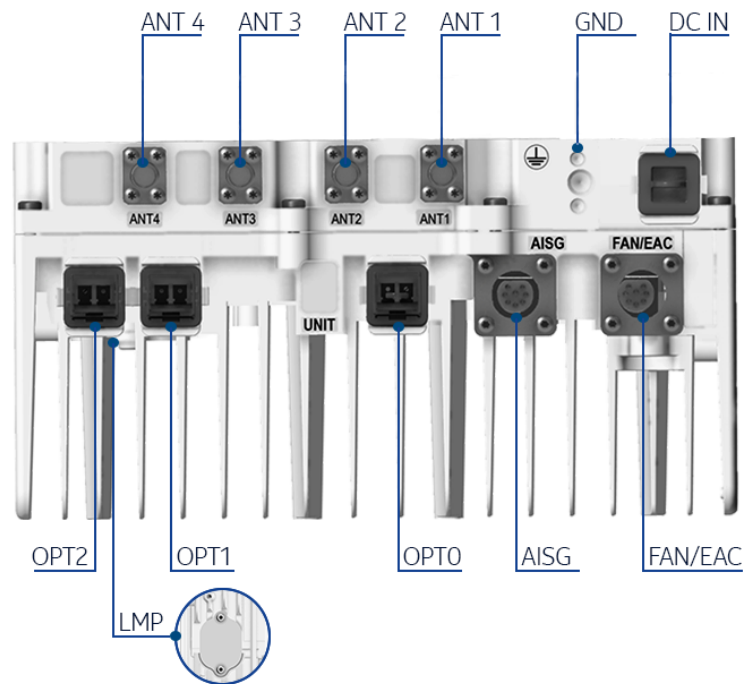

Table 475 AWHHD interfaces

Interface	Label on the HW	Number of interfaces	Connector type	Additional info
Power Connector	DC IN	1	DC OCTIS Plug Kit	Hot insert not supported
Antenna connector	ANT	4	NEX 10	-
Fan/External Alarm Connection	FAN/EAC	1	CIRC 8F IP67 Flange	Two external alarms supported
Optical interface	OPT	3	OCTIS Plug Kit SFP/SFP+	9.8 Gbps, CPRI
Grounding		1	M8 or 2 x M5 screw	-
AISG connector	AISG	1	8-pin circular	-
Local Management Port (LMP)	-	1	2x20-pin female header	Located on the heat sink



WARNING! Risk of electric shock

Before turning RF power on, RF ports have to be terminated by nominal 50 Ω load (for example, feeder with antenna). However, if these conditions are not met, the plastic caps that are delivered within the unused RF ports should remain in place. The plastic caps isolate RF port from the environment, and thus provide electric shock security in case RF power is accidentally on.

Antenna Line Devices (ALDs) support

Table 476 AWHHD ALD support

Property	Value
AISG	AISG 2.0
CWA (for non-AISG installations)	No
Voltage	24 V
Power per port	30 W

Functional block diagram

Figure 134 AWHHD functional block diagram

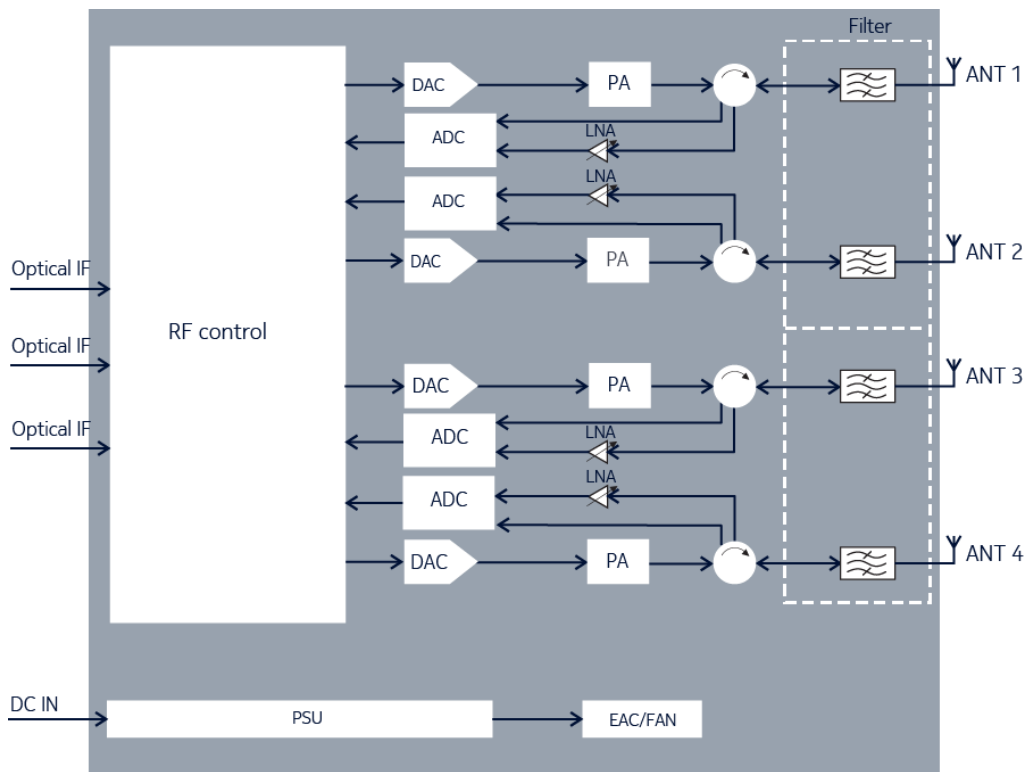

Electrical specifications

Table 477 AWHHD electrical specifications

Property	Value
Nominal supply voltage	-48 V DC
Nominal input voltage range	-40.5 to -57 V DC 85 to 288 V AC (through an external AC/DC converter)
Extended input voltage range	-36 to -40.5 V and -57 to -60 V DC



Note: The minimum startup voltage is -40.5 V DC. If the input voltage is below/beyond extended limits, the unit might shut down.

Power consumption



Note: AWHHD power consumption will be provided in future releases.

Power reduction



Note: The maximum power reduction (`dlCellPwrRed`) value is 20 dB. High power reduction values may cause radio outages.

Related optional items

- OCTIS Plug Kit AC Power (474244A)
- OCTIS Plug Kit DC Power (474184A)
- OCTIS Plug Kit SFP (475756A)
- AMBA AirScale Micro Bracket Assembly Kit (474182A)
- FMWG AirScale Micro Wall/Pole Mount Kit for Single Radio (474013A)
- AAHL AirScale Micro Integrated Antenna (475160A)
- APAH AirScale Micro AC PSU (475043A)

Installation options

- Pole: on the back of the unit or sideways
- Wall: on the back of the unit or sideways



NOTICE: Always install this RRH in a vertical orientation with connectors on the bottom side, to ensure convection cooling.

Dimensions and weight

Table 478 AWHHD dimensions and weight

Property	Value	Dimensions orientation
Height	345 mm (13.58 in.)	
Width	Core RRH (DC version): 245 mm (9.65 in.) RRH with an AC adapter (AC version): 270 mm (10.63 in.)	
Depth	130 mm (5.12 in.)	
Weight	Core RRH (DC version): 11.0 kg (24.3 lb) RRH with an AC adapter (AC version): 12.8 kg (28.2 lb)	

Environmental specifications

Table 479 AWHHD environmental specifications

Property	Value
Maximum operational outdoor temperature in the shade, with 3.0 m/s airflow (in the direction where the airflow has at least effect) and 70% traffic load at temperatures above 45°C	55°C (131°F) for altitude from –100 m to 1800 m 45°C (113°F) for altitude from 1800 m to 4000 m
Maximum operational outdoor temperature in the sun, with 0.5 m/s airflow	45°C (113°F)
Maximum indoor temperature	45°C (113°F)
Minimum operational temperature	–40°C (–40°F)
IP rating	IP65

LTE5161 feature interdependencies

The *LTE5161: Nokia AirScale Micro RRH 4T4R 80 W (AWHHD)* feature is impacted by the following features:

- *LTE112: Cell Bandwidth - 20 MHz* enables LTE 20 MHz carriers.
- With *LTE614: Distributed Site*, AWHHD can be used in distributed sites with up to 23 km (14.29 mi) fiber length to the system module.
- *LTE1103: Load based Power Saving for multilayer networks* and *LTE1203: Load based Power Saving mode with TX power reduction or path switching off* need to be enabled to use PA shutdown feature.
- *LTE2428: Nokia CPRI in FDD-LTE* provides support for CPRI interface.
- *LTE2508: BTS Embedded Power Meter for Energy Efficiency Monitoring* provides energy-monitoring software support for Radio Frequency (RF) modules.
- With *LTE2541: Nokia CPRI RRH/RFM chaining*, AWHHD supports Nokia CPRI chain of up to four radio units.
- *LTE3036: Micro DTX extension* enables to reduce the power consumption of the eNB.

6.12 Nokia AirScale Micro RRH 4T4R B41/n41 80 W (AWHHF)

AWHHF (475181A) is introduced by LTE5304/5GC001707: AirScale Micro 4T4R B41/n41 80 W AWHHF.

Functional description

Table 480 AWHHF functional specification

Property	Value
Output power	4x20 W
Output power of the cell per TX	30 to 43 dBm
QAM	256 QAM (DL)

Table 480 AWHHF functional specification (Cont.)

Property	Value
	64 QAM (UL)
Number of TXRX	4T4R
Outdoor installation	Yes
Beamforming	No
Supported technologies (standalone and MSR)	TD-LTE, 5G
Frequency range	2496–2690 MHz
Filter bandwidth	194 MHz
iBW (instantaneous bandwidth)	194 MHz
oBW (occupied bandwidth)	160 MHz
Number of carriers per pipe	3 x LTE + 1 x 5G NR
Supported bandwidths	LTE: 20 MHz 5G: 40 MHz

Interfaces

Figure 135 AWHHF interfaces

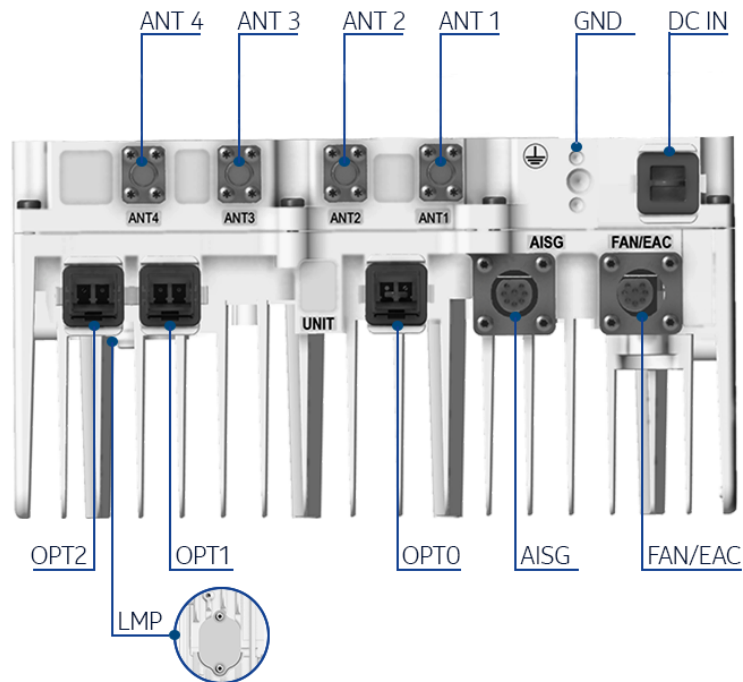



Table 481 AWHHF interfaces

Interface	Label on the HW	Number of interfaces	Connector type	Additional info
Power Connector	DC IN	1	DC OCTIS Plug Kit	Hot insert not supported
Antenna connector	ANT	4	NEX 10	-
Fan/External Alarm Connection	FAN/EAC	1	CIRC 8F IP67 Flange	Two external alarms supported
Optical interface	OPT	3	OCTIS Plug Kit SFP/SFP+	9.8 Gbps, CPRI
Grounding		1	M8 or 2 x M5 screw	-
AISG connector	AISG	1	8-pin circular	-
Local Management Port (LMP)	-	1	2x20-pin female header	Located on the heat sink



WARNING! Risk of electric shock

Before turning RF power on, RF ports have to be terminated by nominal 50 Ω load (for example, feeder with antenna). However, if these conditions are not met, the plastic caps that are delivered within the unused RF ports should remain in place. The plastic caps isolate RF port from the environment, and thus provide electric shock security in case RF power is accidentally on.

Antenna Line Devices (ALDs) support

Table 482 AWHHF ALD support

Property	Value
AISG	AISG 2.0
CWA (for non-AISG installations)	No
Voltage	24 V
Power per port	30 W

Functional block diagram

Figure 136 AWHHF functional block diagram

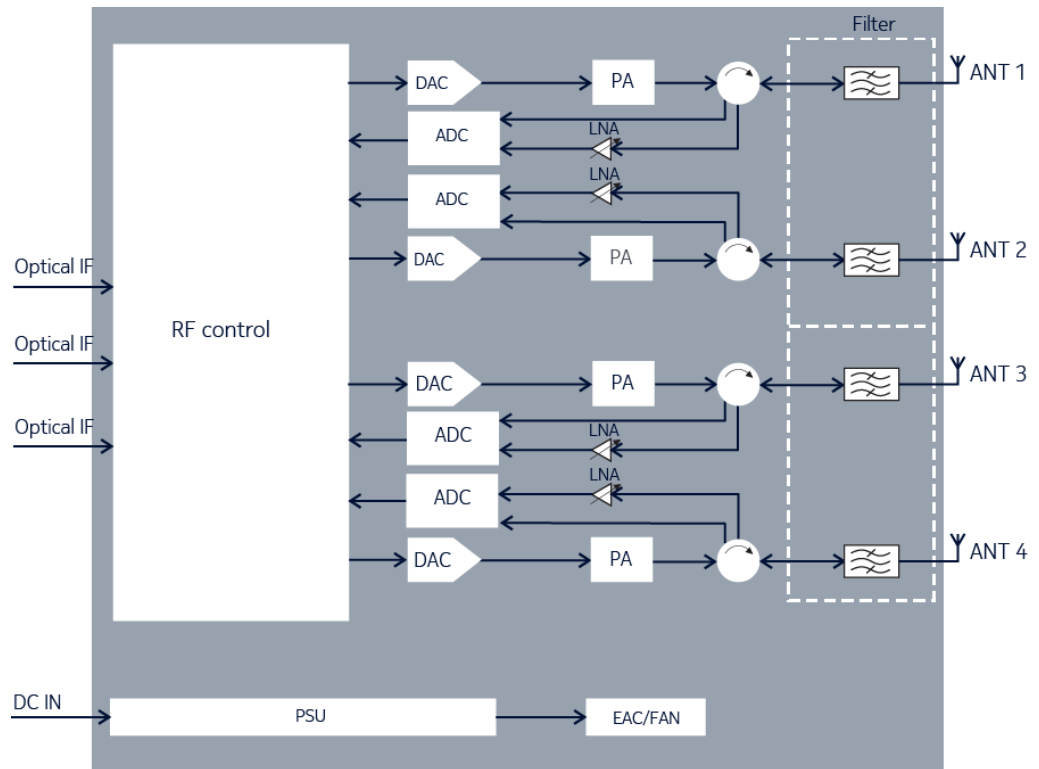

Electrical specifications

Table 483 AWHHF electrical specifications

Property	Value
Nominal supply voltage	-48 V DC
Nominal input voltage range	-40.5 to -57 V DC 85 to 288 V AC (through an external AC/DC converter)
Extended input voltage range	-36 to -40.5 V and -57 to -60 V DC

i **Note:** The minimum startup voltage is -40.5 V DC. If the input voltage is below/beyond extended limits, the unit might shut down.

Power consumption

i **Note:** AWHHF power consumption will be provided in future releases.

Power reduction

i **Note:** The maximum power reduction (dlCellPwrRed) value is 20 dB. High power reduction values may cause radio outages.

Related optional items

- OCTIS Plug Kit AC Power (474244A)
- OCTIS Plug Kit DC Power (474184A)
- OCTIS Plug Kit SFP (475756A)
- AMBA AirScale Micro Bracket Assembly Kit (474182A)
- FMWG AirScale Micro Wall/Pole Mount Kit for Single Radio (474013A)
- FMWV AirScale Micro RRH Enclosure (475185A)
- AAHM AirScale Micro Integrated Antenna (475211A)
- APAH AirScale Micro AC PSU (475043A)

Installation options

- Pole: on the back of the unit or sideways
- Wall: on the back of the unit or sideways
- Inside enclosure



NOTICE: Always install this RRH in a vertical orientation with connectors on the bottom side, to ensure convection cooling.

Dimensions and weight

Table 484 AWHHF dimensions and weight

Property	Value	Dimensions orientation
Height	345 mm (13.58 in.)	
Width	Core RRH (DC version): 245 mm (9.65 in.) RRH with an AC adapter (AC version): 270 mm (10.63 in.)	
Depth	130 mm (5.12 in.)	
Weight	Core RRH (DC version): 11.0 kg (24.3 lb) RRH with an AC adapter (AC version): 12.8 kg (28.2 lb)	

Environmental specifications

Table 485 AWHHF environmental specifications

Property	Value
Maximum operational outdoor temperature in the shade, with 3.0 m/s airflow (in the direction where the airflow has at least effect) and 70% traffic load at temperatures above 45°C	55°C (131°F) for altitude from –100 m to 1800 m 45°C (113°F) for altitude from 1800 m to 4000 m
Maximum operational outdoor temperature in the sun, with 0.5 m/s airflow	45°C (113°F)

Table 485 AWHHF environmental specifications (Cont.)

Property	Value
Maximum indoor temperature	45°C (113°F)
Minimum operational temperature	−40°C (−40°F)
IP rating	IP65

LTE5275 feature interdependencies

The *LTE5275: Nokia AirScale Micro 4T4R B41 80W AWHHF* feature is impacted by the following features:

- *LTE112: Cell Bandwidth - 20 MHz* enables LTE 20 MHz carriers.
- With *LTE614: Distributed Site*, AWHHF can be used in distributed sites with up to 23 km (14.29 mi) fiber length to the system module.
- *LTE1103: Load based Power Saving for multilayer networks* and *LTE1203: Load based Power Saving mode with TX power reduction or path switching off* need to be enabled to use PA shutdown feature.
- *LTE2428: Nokia CPRI in FDD-LTE* provides support for CPRI interface.
- *LTE2508: BTS Embedded Power Meter for Energy Efficiency Monitoring* provides energy-monitoring software support for Radio Frequency (RF) modules.
- With *LTE2541: Nokia CPRI RRH/RFM chaining*, AWHHF supports Nokia CPRI chain of up to four radio units.
- *LTE3036: Micro DTX extension* enables to reduce the power consumption of the eNB.

6.13 Nokia AirScale Micro 4T4R B42 20 W (AZQD)

AZQD is introduced by *LTE4828: Nokia AirScale Micro 4T4R B42 20 W (AZQD)*.

Functional description

Table 486 AZQD functional specification

Property	Value
Output power	4x5 W
QAM	256 QAM (DL) 64 QAM (UL)
Number of TXRX	4T4R
Outdoor installation	Yes
Beamforming	No
Supported technologies (standalone and MSR)	TD-LTE, 5G-ready
Filter bandwidth	200 MHz
Frequency range	3400 - 3600 MHz

Table 486 AZQD functional specification (Cont.)

Property	Value
iBW (instantaneous bandwidth)	80 MHz
oBW (occupied bandwidth)	80 MHz
Number of carriers per pipe	Up to 4
Supported bandwidths	5, 10, 15, 20 MHz

Interfaces

Figure 137 AZQD interfaces

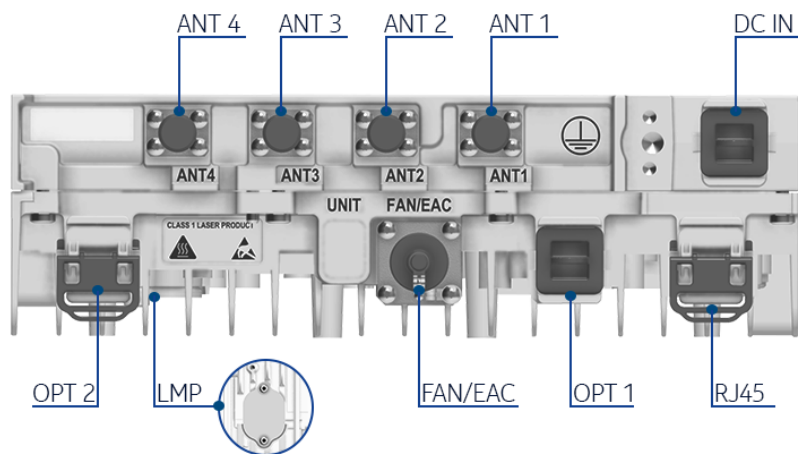

Table 487 AZQD interfaces

Interface	Label on the HW	Number of interfaces	Connector type	Additional info
Power Connector	DC IN	1	DC OCTIS Plug Kit	Hot insert not supported
Antenna connector	ANT	4	NEX 10	-
External Alarm Connection/Fan	EAC/FAN	1	CIRC 8F IP67 Flange	Hot insert not supported
Optical interface	OPT	2	OCTIS Plug Kit SFP/SFP+	9.8 Gbps, CPRI
Ethernet	RJ	1	RJ45	-
Grounding		1	M8 or two M5 screws	-

Table 487 AZQD interfaces (Cont.)

Interface	Label on the HW	Number of interfaces	Connector type	Additional info
Local Management Port (LMP)	-	1	2x20-pin female header	-



WARNING! Risk of electric shock

Before turning RF power on, RF ports have to be terminated by nominal 50 Ω load (for example, feeder with antenna). However, if these conditions are not met, the plastic caps that are delivered within the unused RF ports should remain in place. The plastic caps isolate RF port from the environment, and thus provide electric shock security in case RF power is accidentally on.

Antenna Line Devices (ALDs) support



Note: There is no Antenna Line Device support for AZQD.

Functional block diagram

Figure 138 AZQD functional block diagram

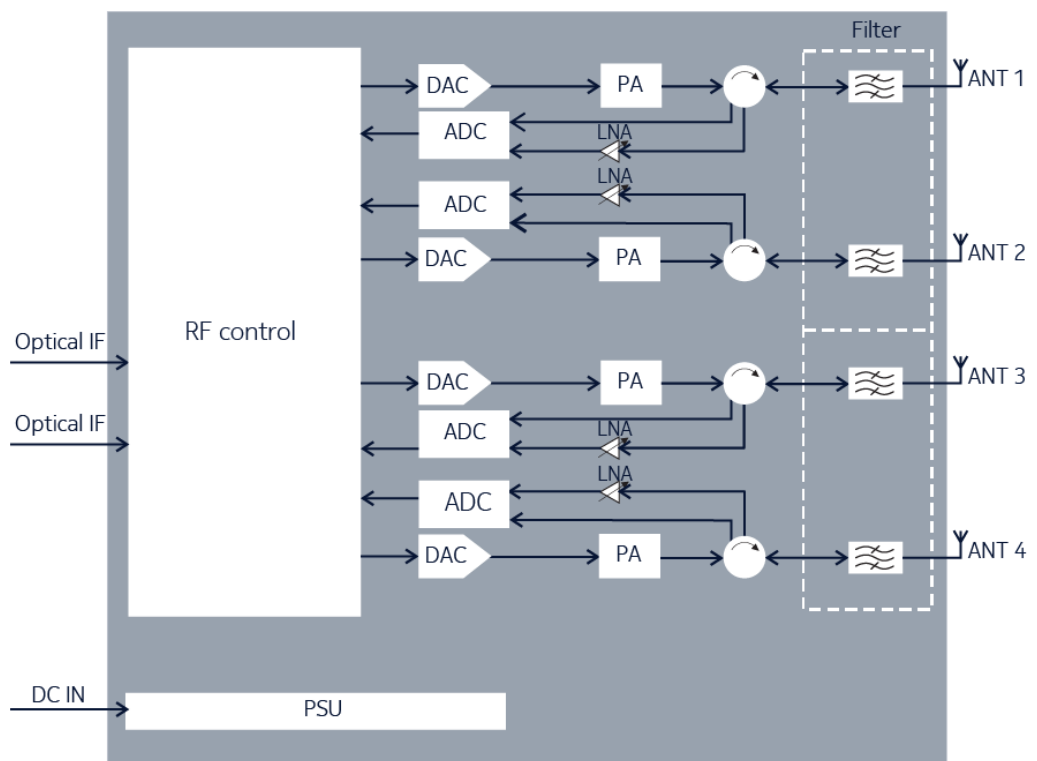

Electrical specifications

Table 488 AZQD electrical specifications

Property	Value
Nominal supply voltage	DC: -48 V AC: 220 V

Table 488 AZQD electrical specifications (Cont.)

Property	Value
Nominal input voltage range	DC: -40.5 V to -57 V AC: 80 V to 276 V (through external AC/DC converter), 45 Hz to 65 Hz
Extended input voltage range	DC: -36 V to -40.5 V DC: -57 V to -60 V



Note: The minimum startup voltage is -40.5 V DC. If the input voltage is below/beyond extended limits, the unit might shut down.

Power consumption



Note: AZQD power consumption will be provided in future releases.

Power reduction



Note: The maximum power reduction (dlCellPwrRed) value is 20 dB. High power reduction values may cause radio outages.

Related optional items

- OCTIS Plug Kit AC Power (474244A)
- OCTIS Plug Kit DC Power (474184A)
- OCTIS Plug Kit SFP (474183A)
- APAE AirScale Micro AC PSU (474518A)
- AMBA AirScale Micro Bracket Assembly Kit (474182A)
- AMBC AirScale Micro Tilt Mount Kit (474332A)
- AMBK AirScale Micro Horizontal Strand Mount Bracket (474630A)
- AMBL AirScale Micro Horizontal Strand Mount Bracket (474849A)
- AAQA AirScale Micro Integrated Antenna (474520A)
- FMWG AirScale Micro Wall/Pole Mount Kit for Single Radio (474013A)
- FMWH AirScale Micro Wall/Pole Mount Kit for Dual Radios (474312A)

Installation options

- Pole/wall
- Bookshelf mounting
- Tilt mounting
- Enclosure mounting
- Strand mounting



NOTICE: Always install this RRH in a vertical orientation with connectors on the bottom side, to ensure convection cooling.

Dimensions and weight

Table 489 AZQD dimensions and weight

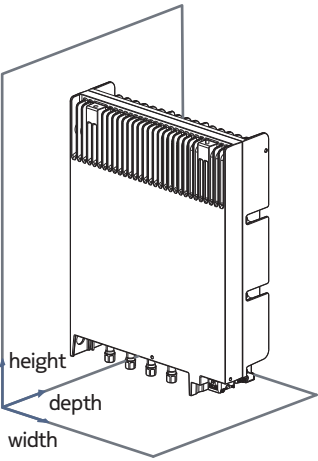
Property	Value	Dimensions orientation
Height	295 mm (11.61 in.)	
Depth	75 mm (2.95 in.)	
Width	245 mm (9.65 in.) core unit (DC version) 274 mm (10.79 in.) with AC adapter (AC version)	
Weight	5.4 kg (11.9 lb) core unit (DC version) 6.1 kg (13.4 lb) with AC adapter (AC version)	

Environmental specifications

Table 490 AZQD environmental specifications

Property	Value
Maximum operational outdoor temperature (in the shade)	55°C (131°F)
Maximum operational outdoor temperature (in the sun)	45°C (113°F)
Maximum indoor temperature	45°C (113°F)
Minimum operational temperature	-35°C (-31°F) Cold start from -40°C (-40°F)
IP rating	IP65

LTE4828 feature interdependencies

LTE4828: Nokia AirScale Micro 4T4R B42 20 W (AZQD) supports the following features:

- LTE112: Cell Bandwidth - 20 MHz enables LTE 20 MHz carriers.
- LTE113: Cell Bandwidth - 15 MHz enables LTE 15 MHz carriers.
- LTE114: Cell Bandwidth - 10 MHz enables LTE 10 MHz carriers.
- LTE115: Cell Bandwidth - 5 MHz enables LTE 5 MHz carriers.
- With LTE 614: Distributed Site, AZQD can be used in distributed sites with up to 23 km (14.29 mi) fiber length to the system module.
- With LTE2541: Nokia CPRI RRH/RFM chaining, AZQD supports Nokia CPRI chain of up to four radio units.
- Power saving features:
 - LTE1103: Load based Power Saving for multi-layer networks
 - LTE1203: Load based Power Saving with Tx path switching off

- LTE2508: BTS Embedded Power Meter for Energy Efficiency Monitoring
- LTE3036: Micro DTX extension

6.14 Nokia AirScale Micro 4T4R B43 20 W (AZQR)

AZQR (475148A) is introduced by LTE5235: AirScale Micro 4T4R B43 20 W AZQR.

Functional description

Table 491 AZQR functional specification

Property	Value
Output power	4x5 W
QAM	256 QAM (DL) 64 QAM (UL)
Number of TXRX	4T4R
Outdoor installation	Yes
Beamforming	No
Supported technologies (standalone and MSR)	TD-LTE, 5G-ready
Frequency range	3600 - 3800 MHz
Filter bandwidth	200 MHz
iBW (instantaneous bandwidth)	80 MHz
oBW (occupied bandwidth)	80 MHz
Number of carriers per pipe	Up to 4
Supported bandwidths	10, 15, 20 MHz

Interfaces

Figure 139 AZQR interfaces

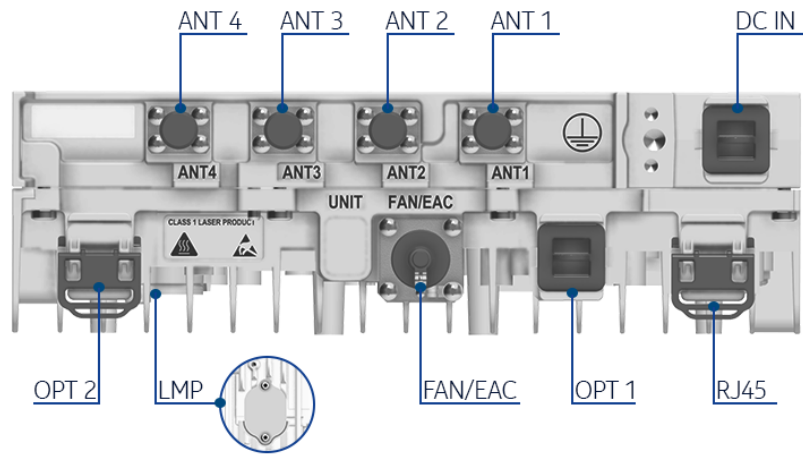

Table 492 AZQR interfaces

Interface	Label on the HW	Number of interfaces	Connector type	Additional info
Power Connector	DC IN	1	DC OCTIS Plug Kit	Hot insert not supported
Antenna connector	ANT	4	NEX 10	-
External Alarm Connection/Fan	EAC/FAN	1	CIRC 8F IP67 Flange	Hot insert not supported
Optical interface	OPT	2	OCTIS Plug Kit SFP/SFP+	9.8 Gbps, CPRI
Ethernet	RJ	1	RJ45	-
Grounding	⏏	1	M8 or two M5 screws	-
Local Management Port (LMP)	-	1	2x20-pin female header	-



WARNING! Risk of electric shock

Before turning RF power on, RF ports have to be terminated by nominal 50 Ω load (for example, feeder with antenna). However, if these conditions are not met, the plastic caps that are delivered within the unused RF ports should remain in place. The plastic caps isolate RF port from the environment, and thus provide electric shock security in case RF power is accidentally on.

Antenna Line Devices (ALDs) support



Note: There is no Antenna Line Device support for AZQR.

Functional block diagram

Figure 140 AZQR functional block diagram

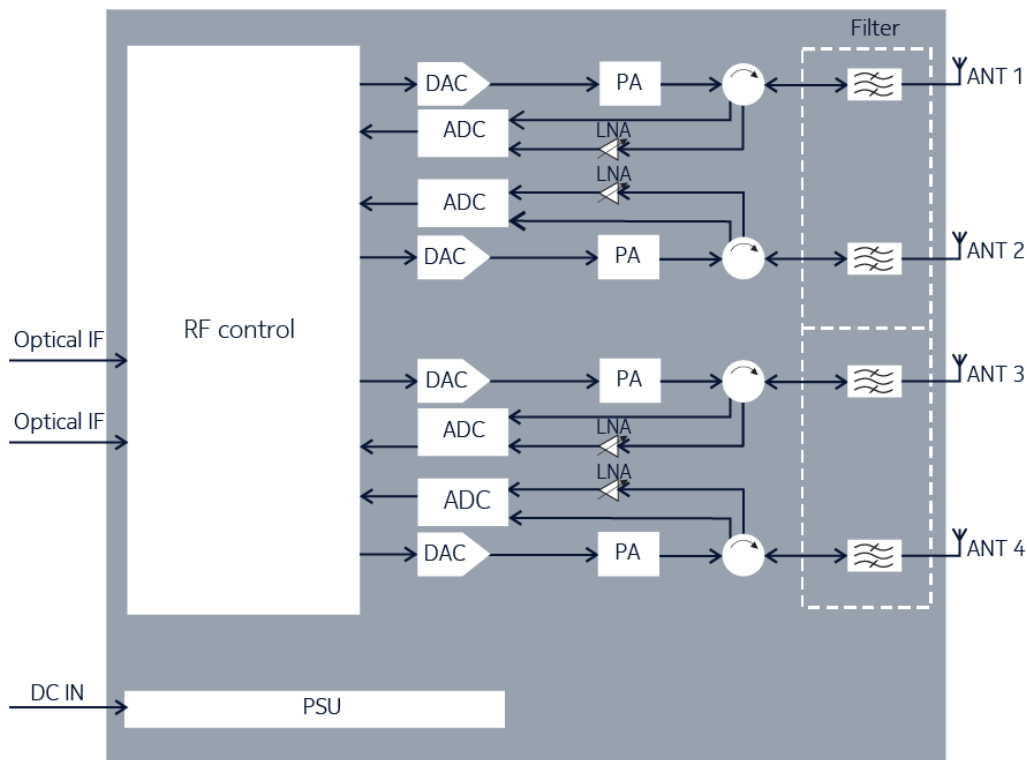

Electrical specifications

Table 493 AZQR electrical specifications

Property	Value
Nominal supply voltage	DC: -48 V AC: 220 V
Nominal input voltage range	DC: -40.5 V to -57 V AC: 80 V to 276 V (through external AC/DC converter), 45 Hz to 65 Hz
Extended input voltage range	DC: -36 V to -40.5 V DC: -57 V to -60 V



Note: The minimum startup voltage is -40.5 V DC. If the input voltage is below/beyond extended limits, the unit might shut down.

Power consumption



Note: AZQR power consumption will be provided in future releases.

Power reduction



Note: The maximum power reduction (`d1CellPwrRed`) value is 20 dB. High power reduction values may cause radio outages.

Related optional items

- AMBA AirScale Micro Bracket Assembly Kit (474182A)
- AMBC AirScale Micro Tilt Mount Kit (474332A)
- AMBK Horizontal Strand Mount Hardware Bracket (474630A)
- AMBL Horizontal Strand Mount Hardware Bracket (474849A)
- FMWG AirScale Micro Wall/Pole Mount Kit for Single Radio (474013A)
- FMWH Wall/Pole Mount Kit for Dual Radios (474312A)
- APAE AirScale Micro AC PSU (474518A)
- AAQA AirScale Micro Integrated Antenna (474520A)
- OCTIS Plug Kit AC Power (474244A)
- OCTIS Plug Kit DC Power (474184A)
- OCTIS Plug Kit SFP (474183A)

Installation options

- Pole
- Wall
- Bookshelf
- Strand
- Enclosure



NOTICE: Always install this RRH in a vertical orientation with connectors on the bottom side, to ensure convection cooling.

Dimensions and weight

Table 494 AZQR dimensions and weight

Property	Value	Dimensions orientation
Height	295 mm (11.61 in.)	
Width	Core RRH (DC version): 245 mm (9.65 in.) RRH with an AC adapter (AC version): 274 mm (10.79 in.)	
Depth	75 mm (2.95 in.)	
Weight	Core RRH (DC version): 5.4 kg (11.9 lb) RRH with an AC adapter (AC version): 6.1 kg (13.5 lb)	

Environmental specifications

Table 495 AZQR environmental specifications

Property	Value
Maximum operational outdoor temperature (in the shade)	55°C (131°F)
Maximum operational outdoor temperature (in the sun)	45°C (113°F)
Maximum indoor temperature	45°C (113°F)
Minimum operational temperature	-35°C (-31°F) Cold start from -40°C (-40°F)
IP rating	IP65

LTE5235 feature interdependencies

The *LTE5235: Nokia AirScale Micro 4T4R 20 W (AZQR)* feature is impacted by the following features:

- *LTE112: Cell Bandwidth - 20 MHz* enables LTE 20 MHz carriers.
- *LTE113: Cell Bandwidth - 15 MHz* enables LTE 15 MHz carriers.
- *LTE114: Cell Bandwidth - 10 MHz* enables LTE 10 MHz carriers.
- With *LTE 614: Distributed Site*, AZQR can be used in distributed sites with up to 23 km (14.29 mi) fiber length to the system module.
- With *LTE2541: Nokia CPRI RRH/RFM chaining*, AZQR supports Nokia CPRI chain of up to four radio units.
- Power saving features:
 - *LTE1103: Load based Power Saving for multi-layer networks*
 - *LTE1203: Load based Power Saving with Tx path switching off*
 - *LTE2508: BTS Embedded Power Meter for Energy Efficiency Monitoring*
 - *LTE3036: Micro DTX extension*

6.15 Nokia AirScale Micro 4T4R B66 20 W (AHIB)

AHIB is introduced by LTE3431/SR002530/5GC001189: Nokia AirScale Micro 4T4R B66 20 W (AHIB).

Functional description

Table 496 AHIB functional specification

Property	Value
Output power	4x5 W
QAM	256QAM (DL) 64 QAM (UL)
Number of TXRX	4T4R

Table 496 AHIB functional specification (Cont.)

Property	Value
Outdoor installation	Yes
Supported technologies (standalone and MSR)	FDD-LTE, WCDMA-LTE, 5G
TX frequency range	2110–2200 MHz
RX frequency range	1710–1780 MHz
DL filter bandwidth	90 MHz
UL filter bandwidth	70 MHz
iBW (instantaneous bandwidth)	70 MHz
oBW (occupied bandwidth)	70 MHz
Number of carriers per pipe	Up to 4
Supported bandwidths	LTE: 1.4, 3, 5, 10, 15, 20 MHz WCDMA: 5 MHz 5G: 20 MHz

Interfaces

Figure 141 AHIB interfaces

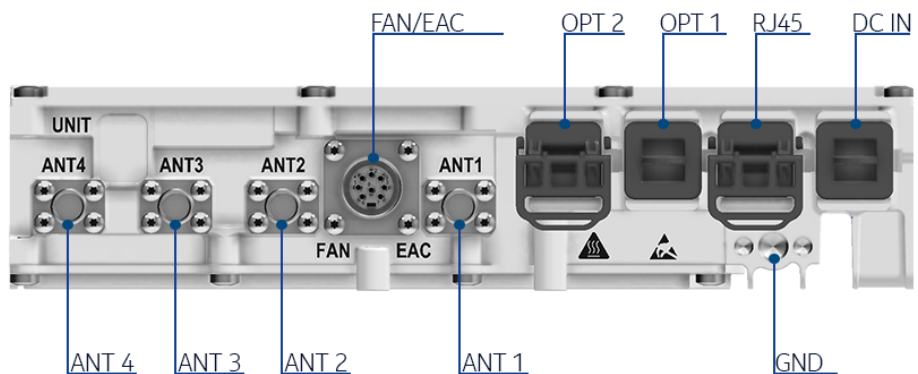



Table 497 AHIB interfaces

Interface	Label on the HW	Number of interfaces	Connector type	Additional info
Power Connector	DC IN	1	OCTIS Plug Kit	Hot insert not supported

Table 497 AHIB interfaces (Cont.)

Interface	Label on the HW	Number of interfaces	Connector type	Additional info
Antenna connector	ANT	4	NEX10	-
External Alarm Connection / Fan	FAN/EAC	1	CIRC 8F IP67 Flange	Hot insert not supported
Optical interface	OPT	2	OCTIS Plug Kit SFP/SFP+	9.8 Gbps, CPRI
Ethernet	RJ	1	RJ45	Separate feature required to enable this interface
Ground		1	M8 or dual M5 screws	-



WARNING! Risk of electric shock

Before turning RF power on, RF ports have to be terminated by nominal 50 Ω load (for example, feeder with antenna). However, if these conditions are not met, the plastic caps that are delivered within the unused RF ports should remain in place. The plastic caps isolate RF port from the environment, and thus provide electric shock security in case RF power is accidentally on.

Antenna Line Devices (ALDs) support



Note: There is no Antenna Line Device support for AHIB.

Functional block diagram

Figure 142 AHIB functional block diagram

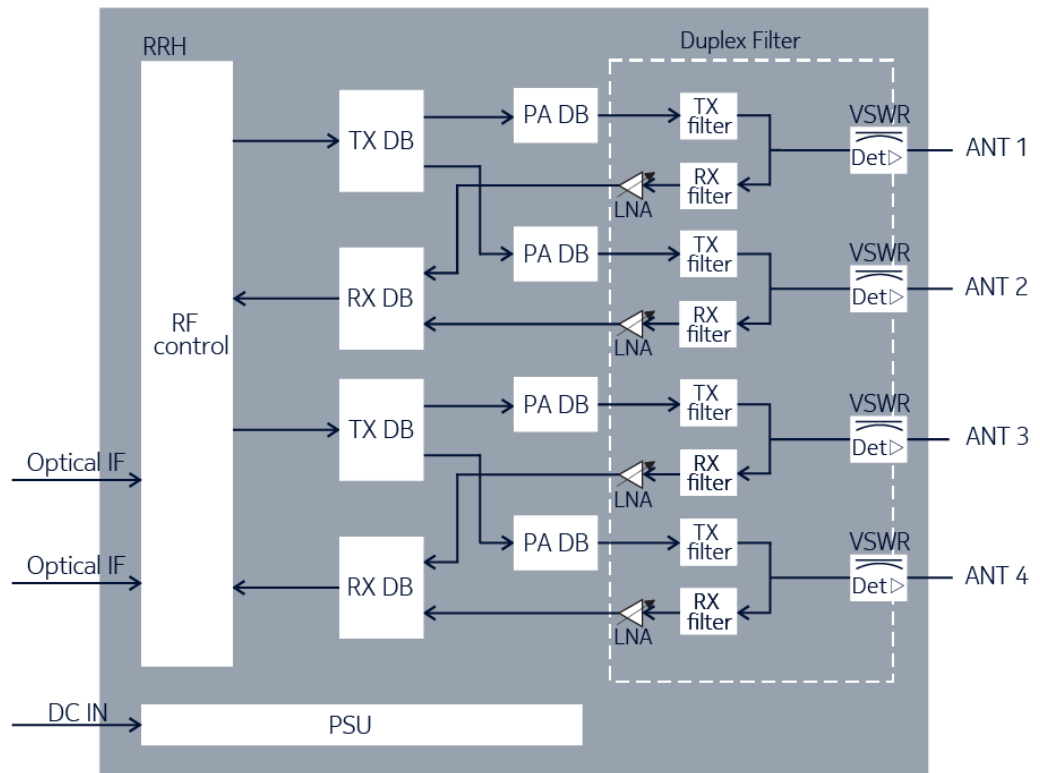

Electrical specifications

Table 498 AHIB electrical specifications

Property	Value
Nominal supply voltage	-48.0 V DC
Nominal input voltage range	-40.5 V DC to -57.0 V DC
Extended input voltage range	-36 V to -40.5 V and -57 V to -60 V (DC)



Note: The minimum startup voltage is -40.5 V DC. If the input voltage is below/beyond extended limits, the unit might shut down.

Power consumption

Typical power consumption [W] for 48VDC input, at 25°C, representative of typical product performance under the same conditions (HW variant, SW version, configuration, environment, and so on) with +/- 10% margin. Average = (6h low hour load, 10h medium hour load and 8h busy hour load) / 24h

Configurations explained on examples:

- GSM/WCDMA: 2/2/2 = three sectors, two carriers/TRXs per sector
- LTE:
 - o 2/2/2 2Tx = three sectors, two carriers per sector, 2Tx per carrier
 - o 1+1/1+1/1+1 4Tx = three dual-band sectors, one carrier per sector per band, 4Tx per carrier

Some radio units are capable of providing only one sector coverage. Then the power values in the table consider deployment of three radio units.

Table 499 AHIB power consumption in LTE mode

Configuration	Output power per carrier [W]	Power consumption ETSI 202706 average $P_{RRH, static}$	Power consumption ETSI 202706 busy hour load $P_{BH, RRH, static}$	Power consumption 100% RF power load $P_{100\% RRH}$
1 sector 2Tx	2x5	70	76	89
1 sector 4Tx	4x5	95	109	136



Note: Power consumption in 5G mode will be provided in a future release.

Power reduction



Note: The maximum power reduction ($dlCellPwrRed$) value is 20 dB. High power reduction values may cause radio outages.

Related optional items

- APAB AirScale Micro AC PSU (474130A)
- OCTIS Plug Kit AC Power (474244A)
- OCTIS Plug Kit DC Power (474184A)
- OCTIS Plug Kit SFP (474183A)
- AMBA AirScale Micro Bracket Assembly Kit (474182A)
- AAFA AirScale Micro Integrated Antenna (474185A)
- AMBC AirScale Micro Tilt Mount Kit (474332A)
- AMBK AirScale Micro Horizontal Strand Mount Bracket (474630A)
- AMBL AirScale Micro Horizontal Strand Mount Bracket (474849A)
- FMWG AirScale Micro Wall/Pole Mount Kit for Single Radio (474013A)
- FMWH AirScale Micro Wall/Pole Mount Kit for Dual Radios (474312A)
- FMWM AirScale Micro RRH Enclosure (474431A)
- FMWV AirScale Micro RRH Enclosure (475185A)

Installation options

- Pole
- Wall
- Enclosure
- Strand
- Bookshelf mounting
- Tilt mounting



NOTICE: Always install this RRH in a vertical orientation with connectors on the bottom side, to ensure convection cooling.

Dimensions and weight

Table 500 AHIB dimensions and weight

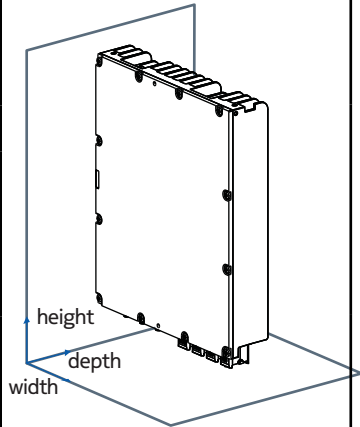
Property	Value	Dimensions orientation
Height	295 mm (11.61 in.)	
Depth	55 mm (2.17 in.)	
Width	245 mm (9.65 in.) core unit (DC version) 270 mm (10.63 in.) with AC adapter (AC version)	
Weight	5.4 kg (11.9 lb) core unit (DC version) 6.1 kg (13.4 lb) with AC adapter (AC version)	

Environmental specifications

Table 501 AHIB environmental specifications

Property	Value
Maximum operational outdoor temperature in the shade, assuming wind speed is 3 m/s (at constant high ambient temperature, maximum output power might be limited)	55°C (131°F)
Maximum operational outdoor temperature in the sun, assuming wind speed is 0.5 m/s (at constant high ambient temperature, maximum output power might be limited)	45°C (113°F)
Maximum indoor temperature, assuming wind speed is 0 m/s, valid for fanless products (at constant high ambient temperature, maximum output power might be limited)	45°C (113°F)
Minimum operational temperature (including cold start)	-35°C (-31°F) Cold start from -40°C (-40°F)
IP rating	IP65

Feature interdependencies

The *LTE3431: Nokia AirScale Micro 4T4R B66 20 W (AHIB)* feature is impacted by the following features:

- *LTE112: Cell Bandwidth - 20 MHz* enables LTE 20 MHz carriers.
- *LTE113: Cell Bandwidth - 15 MHz* enables LTE 15 MHz carriers.
- *LTE114: Cell Bandwidth - 10 MHz* enables LTE 10 MHz carriers.
- *LTE115: Cell Bandwidth - 5 MHz* enables LTE 5 MHz carriers.
- *LTE116: Cell Bandwidth - 3 MHz* enables LTE 3 MHz carriers.
- *LTE117: Cell Bandwidth - 1.4 MHz* enables LTE 1.4 MHz carriers.

- With *LTE614: Distributed Site*, AHIB can be used in distributed sites with up to 23 km fiber length to the system module.
- *LTE1103: Load based Power Saving for multilayer networks*
- *LTE1203: Load based Power Saving mode with TX power reduction or path switching off*
- *LTE2508: BTS Embedded Power Meter for Energy Efficiency Monitoring*
- With *LTE2541: Nokia CPRI RRH/RFM chaining*, AHIB supports Nokia CPRI chain of up to four radio units.
- *LTE3036: Micro DTX extension*

6.16 Nokia AirScale Micro 4T4R CBRS 20 W (AZQC)

AZQC is introduced by *LTE3628: Nokia AirScale Micro 4T4R CBRS 20 W (AZQC)*.

Functional description

Table 502 AZQC functional specification

Property	Value
Output power	4x5 W
QAM	up to 256 QAM DL
	up to 64 QAM UL
Number of TXRX	4T4R
Outdoor installation	Yes
Beamforming	No
Supported technologies (standalone and MSR)	TD-LTE, 5G-ready
Frequency range	3550 - 3700 MHz
Filter bandwidth	150 MHz
iBW (instantaneous bandwidth)	150 MHz  Note: 150 MHz is conditionally supported. It is limited by any adjacent two carriers. The distance from the first carrier's center to the second carrier's farther edge cannot be larger than 110 MHz.
oBW (occupied bandwidth)	80 MHz
Number of carriers per pipe	Up to 4
Supported bandwidths	10, 20 MHz

Interfaces

Figure 143 AZQC interfaces

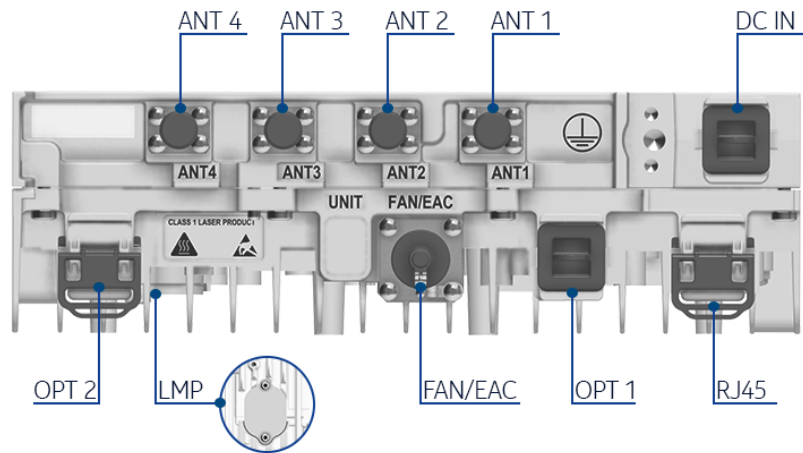



Table 503 AZQC interfaces

Interface	Label on the HW	Number of interfaces	Connector type	Additional info
Power Connector	DC IN	1	DC Octis Plug Kit	Hot insert not supported
Antenna connector	ANT	4	NEX 10	-
External Alarm Connection/Fan	EAC/FAN	1	CIRC 8F IP67 Flange	Hot insert not support
LED	UNIT	1	-	-
Optical interface	OPT	2	OCTIS Plug Kit SFP/SFP+	9.8 Gbps, CPRI
Ethernet	RJ	1	RJ45	Separate feature required to enable this interface
Grounding		1	M8 or dual M5 screws	-
Local Management Port	-	1	2x20-pin female header	-



WARNING! Risk of electric shock

Before turning RF power on, RF ports have to be terminated by nominal 50 Ω load (for example, feeder with antenna). However, if these conditions are not met, the plastic caps that are delivered within the unused RF ports should remain in place. The plastic caps isolate RF port from the environment, and thus provide electric shock security in case RF power is accidentally on.

Antenna Line Devices (ALDs) support



Note: There is no Antenna Line Device support for the AZQC.

Functional block diagram

Figure 144 AZQC functional block diagram

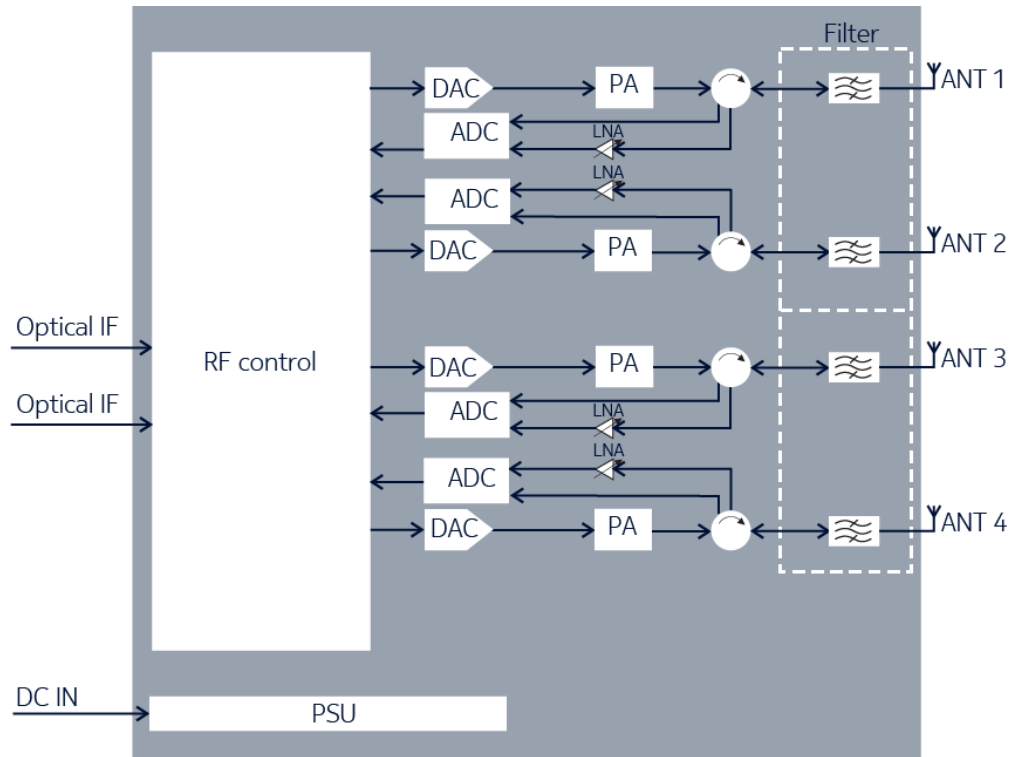

Electrical specifications

Table 504 AZQC electrical specifications

Property	Value
Nominal supply voltage	-48.0 V DC
Nominal input voltage range	-40.5 V DC to -57.0 V DC
Extended input voltage range	-36 V to -40.5 V and -57 V to -60 V (DC)



Note: The minimum startup voltage is -40.5 V DC. If the input voltage is below/beyond extended limits, the unit might shut down.

Power consumption

Typical power consumption [W] for 48VDC input, at 25°C, representative of typical product performance under the same conditions (HW variant, SW version, configuration, environment, and so on) with +/- 10% margin. Average = (6h low hour load, 10h medium hour load and 8h busy hour load) / 24h

Configurations explained on examples:

- GSM/WCDMA: 2/2/2 = three sectors, two carriers/TRXs per sector
- LTE:

- o 2/2/2 2Tx = three sectors, two carriers per sector, 2Tx per carrier
- o 1+1/1+1/1+1 4Tx = three dual-band sectors, one carrier per sector per band, 4Tx per carrier

Some radio units are capable of providing only one sector coverage. Then the power values in the table consider deployment of three radio units.

Table 505 AZQC power consumption in LTE mode

Configuration	Output power per carrier [W]	Power consumption ETSI 202706 average P_{RRH} , static	Power consumption ETSI 202706 busy hour load $P_{BH\ RRH}$, static	Power consumption 100% RF power load $P_{100\% \ RRH}$
1 sector 4Tx	4x5	122	136	158
1 sector 4Tx	4x2	108	115	128



Note: Power consumption values are measured according to ETSI 202 706-1 v1.5 assumptions (subframe #2 and special subframe #7), leading to 74.3% TX duty cycle. Higher TX duty cycle causes higher power consumption.

Power reduction



Note: The maximum power reduction (`dlCellPwrRed`) value is 20 dB. High power reduction values may cause radio outages.

Related optional items

- APAE AirScale Micro 210 W AC PSU (474518A)
- OCTIS Plug Kit AC Power (474244A)
- OCTIS Plug Kit DC Power (474184A)
- OCTIS Plug Kit SFP (474183A)
- AMBA AirScale Micro Bracket Assembly Kit (474182A)
- AAQA AirScale Micro Integrated Antenna 3.5G (474520A)
- AMBC AirScale Micro Tilt Mount Kit (474332A)
- FMWG AirScale Micro Wall/Pole Mount Kit for Single Radio (474013A)
- FMWH AirScale Micro Wall/Pole Mount Kit for Dual Radios (474312A)
- FMWV AirScale Micro RRH Enclosure (475185A)
- AMGP AirScale Micro cover 245 x 288 (474705A)

Installation options

- Pole installation
- Wall installation
- Bookshelf mounting
- Enclosure mounting



NOTICE: Always install this RRH in a vertical orientation with connectors on the bottom side, to ensure convection cooling.

Dimensions and weight

Table 506 AZQC dimensions and weight

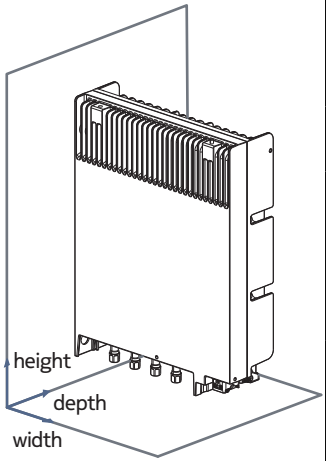
Property	Value	Dimensions orientation
Height	295 mm (11.6 in.)	
Depth	75 mm (3.0 in.)	
Width	245 mm (9.6 in.) core unit (DC version) 270 mm (10.6 in.) with AC adapter (AC version)	
Weight	6.5 kg (14.3 lb) core unit (DC version) 7.6 kg (16.8 lb) with AC adapter (AC version)	

Environmental specifications

Table 507 AZQC environmental specifications

Property	Value
Maximum operational outdoor temperature (in the shade)	55°C (131°F)
Maximum operational outdoor temperature (in the sun)	45°C (113°F)
Maximum indoor temperature	45°C (113°F)
Minimum operational temperature (including cold start)	-35°C (-31°F) Cold start from -40°C (-40°F)

LTE3628 feature interdependencies

LTE3628: Nokia AirScale Micro 4T4R CBRS 20 W AZQC supports the following features:

- LTE112: Cell Bandwidth - 20 MHz enables LTE 20 MHz carriers.
- LTE114: Cell Bandwidth - 10 MHz enables LTE 10 MHz carriers.
- With LTE614: Distributed Site, AZQC can be used in distributed sites with up to 23km fiber length to the system module.
- With LTE2541: Nokia CPRI RRH/RFM chaining , AZQC supports Nokia CPRI chain of up to 4 radio units.
- RF-sniffing features can be used with AZQC.
- Power saving features:
 - LTE1103: Load based Power Saving for multi-layer networks
 - LTE1203: Load based Power Saving with Tx path switching off
 - LTE2508: BTS Embedded Power Meter for Energy Efficiency Monitoring
 - LTE3036: Micro DTX extension

7 Nokia AirScale Macro TD-LTE Radios

7.1 Nokia AirScale RRH 2T2R B40 120 W (AZND/AZNE)

AZND and AZNE are introduced by LTE3961: Nokia AirScale RRH 2T2R B40 120 W (AZND/AZNE).

Functional description

Table 508 AZND/AZNE functional specification

Property	Value
Output power	2x60 W
QAM	256 QAM (DL)
Number of TXRX	2T2R
Outdoor installation	Yes
Beamforming	No
Supported technologies (standalone and MSR)	TD-LTE
Frequency range	2320 - 2370 MHz
Filter bandwidth	50 MHz
iBW (instantaneous bandwidth)	50 MHz
oBW (occupied bandwidth)	50 MHz
Number of carriers per pipe	Up to 3
Supported bandwidths	10, 20 MHz

Interfaces

Figure 145 AZND interfaces

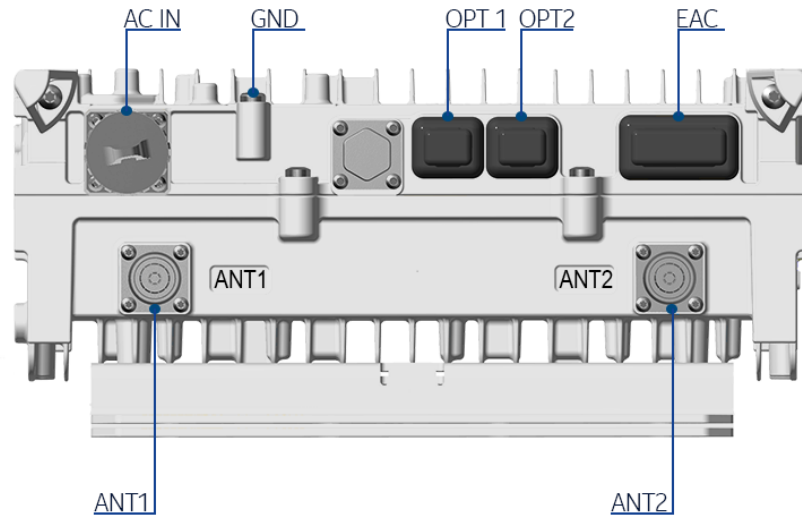

Figure 146 AZNE interfaces

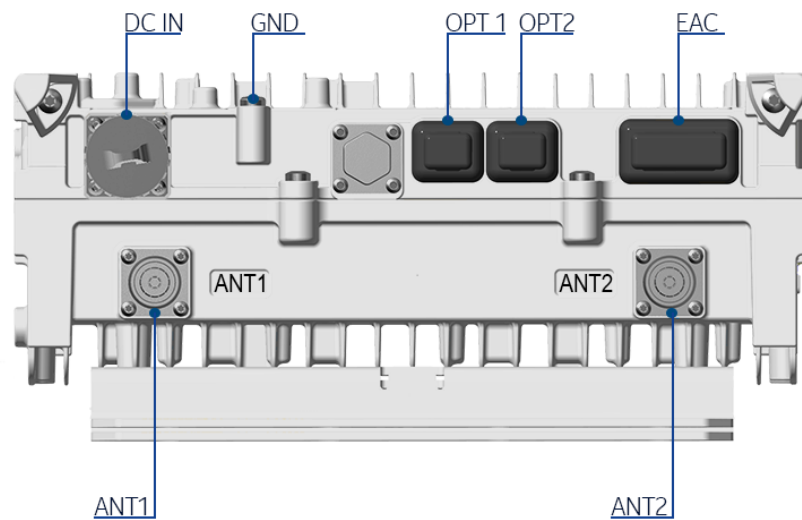



Table 509 AZND/AZNE interfaces

Interface	Label on the HW	Number of interfaces	Connector type	Additional info
Power Connector	AC IN (AZND) DC IN (AZNE)	1	Circular Connector	APPF for AZND APPB for ANZE

Table 509 AZND/AZNE interfaces (Cont.)

Interface	Label on the HW	Number of interfaces	Connector type	Additional info
Antenna connector	ANT	2	4.3-10	-
External Alarm Connection	EAC	1	MDR26	4 alarm inputs and 1 control output
Optical interface	OPT	2	SFP+	9.8 Gbps, CPRI; Nokia IP seal
Grounding		1	2 x M5 screw or 1 x M8 screw	-
Fan	FAN	1	Nokia fan	Located on the opposite side



WARNING! Risk of electric shock

Before turning RF power on, RF ports have to be terminated by nominal 50Ω load (for example, feeder with antenna). However, if these conditions are not met, the plastic caps that are delivered within the unused RF ports should remain in place. The plastic caps isolate RF power from the environment, and thus provide electric shock security in case RF power is accidentally on.

Antenna Line Devices (ALDs) support



Note: There is no Antenna Line Device support for AZND/AZNE.

Functional block diagram

Figure 147 AZND/AZNE functional block diagram

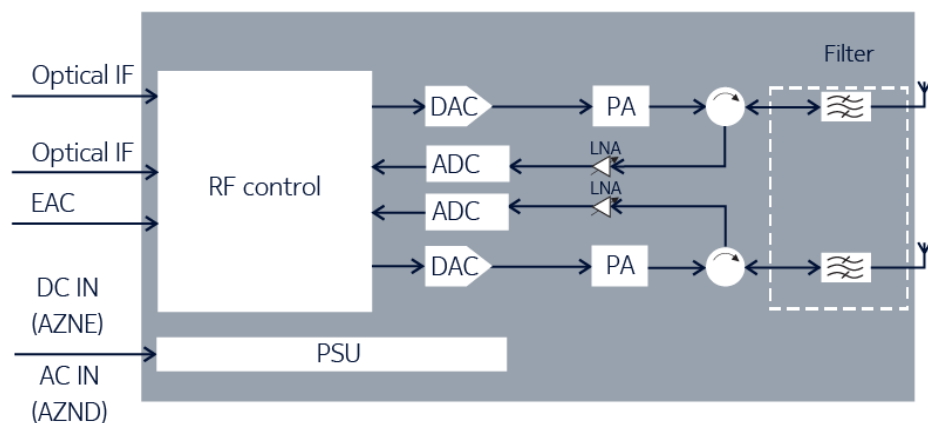

Electrical specifications

Table 510 AZND/AZNE electrical specifications

Property	Value
Nominal supply voltage	AZND: 220 V AC AZNE: -48.0 V DC

Table 510 AZND/AZNE electrical specifications (Cont.)

Property	Value
Nominal input voltage range	AZND: 200 V AC to 240 V AC AZNE: -40.0 V DC to -57.0 V DC
Extended input voltage range	AZND: 140 V AC to 300 V AC AZNE: -36.0 V DC to -40.0 V DC AZNE: -57.0 V DC to -60.0 V DC



Note: The minimum startup voltage is -40.5 V DC. If the input voltage is below/beyond extended limits, unit might shut down.

Power consumption

Typical power consumption [W] for 48VDC input, at 25°C, representative of typical product performance under the same conditions (HW variant, SW version, configuration, environment, and so on) with +/- 10% margin. Average = (6h low hour load, 10h medium hour load and 8h busy hour load) / 24h

Configurations explained on examples:

- GSM/WCDMA: 2/2/2 = three sectors, two carriers/TRXs per sector
- LTE:
 - o 2/2/2 2Tx = three sectors, two carriers per sector, 2Tx per carrier
 - o 1+1/1+1/1+1 4Tx = three dual-band sectors, one carrier per sector per band, 4Tx per carrier

Some radio units are capable of providing only one sector coverage. Then the power values in the table consider deployment of three radio units.

Table 511 AZND power consumption in LTE mode

Configuration	Output power per carrier [W]	Power consumption ETSI 202706 average P_{RRH} , static	Power consumption ETSI 202706 busy hour load $P_{BH\ RRH}$, static	Power consumption 100% RF power load $P_{100\% \ RRH}$
1/1/1 2Tx	2x60	518	669	998
1/1/1 2Tx	2x40	436	533	750
1/1/1 2Tx	2x30	397	469	634
1/1/1 2Tx	2x20	357	405	509

Table 512 AZNE power consumption

Configuration	Output power per carrier [W]	Power consumption ETSI 202706 average P_{RRH} , static	Power consumption ETSI 202706 busy hour load $P_{BH\ RRH}$, static	Power consumption 100% RF power load $P_{100\% \ RRH}$
1/1/1 2Tx	2x60	530	683	1021
1/1/1 2Tx	2x40	444	542	769
1/1/1 2Tx	2x30	406	480	649
1/1/1 2Tx	2x20	366	416	521



Note: Power consumption values are measured according to ETSI 202 706-1 v1.5 assumptions (subframe #2 and special subframe #7), leading to 74.3% TX duty cycle. Higher TX duty cycle causes higher power consumption.

Power reduction

Table 513 Recommended AZND/AZNE power reduction in 256 QAM

Carrier configuration	Power reduction [dB]
Multiple carriers, continuous	0.5
Multiple carriers, non-continuous	0.5
Single carrier	0.5



Note: The maximum power reduction (`dlCellPwrRed`) value is 20 dB. High power reduction values may cause radio outages.

Related optional items

- APAA AirScale AC-DC Power Unit 760W (473936A) only for AZNE
- AMAA AirScale 2 casing for RRH aux-units (474141A):
 - APAC AirScale AC PDU 1 to 3 (474142A)
 - APAA AirScale AC-DC Power Unit 760W (473936A) - maximum three units per one AMAA
- AMBE AirScale book mount kit 101-125 (474277A)
- FPKA Flexi Pole Mounting Kit (30-120 mm) (471649A)
- FPKC Flexi Pole Mounting Kit (60-300 mm) (472821A)
- AMPA Pole Mounting Kit (30-120 mm) (473879A)
- AMFA AirScale 2 FPKx fixing adapter (474289A)
- AMFN AirScale 2 casing adapter RRH 300 (474664A)
- AMRA AirScale one clip bracket 51-125 (474580A)
- AMRC AirScale one clip rail 600 mm (474583A)
- ASAA AirScale 2 MDR26-open EAC cable 5 m (474288A)
- APPF Conn 3 Pole Female Plug AC (474893A) for AZND
- APPB AirScale 2 55A DC plug 3.3-10mm² (474282A) for AZNE

Installation options

- Pole mounting
- Wall mounting (on a rail)
- One-clip rail installation
- Bookshelf mounting – requires the AirScale Book Mount Kit



Note: In case of mounting three modules on a wall (rail) and in bookshelf mounting, AZND/AZNE cannot be mounted as the middle unit.



NOTICE: Install this RRH in a vertical orientation with connectors on the bottom side, to ensure convection cooling. For horizontal installation fans are required.

Dimensions and weight

Table 514 AZND/AZNE dimensions and weight

Property	Value	Dimensions orientation
Height	Core RRH: 336 mm (13.2 in.) With upper and lower mounting brackets: 430.5 mm (16.9 in.)	
Depth	Core RRH: 110 mm (4.3 in.) With mounting brackets: 134 mm (5.3 in.)	
Width	300 mm (11.8 in.)	
Weight	max. 11 kg (24.3 lb)	

Environmental specifications

Table 515 AZND/AZNE environmental specifications

Property	Value
Maximum operational outdoor temperature (in the shade)	55°C (131°F)
Maximum operational outdoor temperature (in the sun)	45°C (113°F)
Maximum indoor temperature	45°C (113°F)
Minimum operational temperature	-40°C (-40°F)
IP rating	IP65

LTE3961 feature interdependencies

LTE3961: AZND/AZNE BSW Nokia AirScale RRH 2T2R B40 120 W supports the following features:

- *LTE112: Cell bandwidth 20 MHz* needs to be enabled to use LTE 20 MHz carriers.
- *LTE114: Cell bandwidth 10 MHz* needs to be enabled to use LTE 10 MHz carriers.

The *LTE3961: AZND/AZNE BSW Nokia AirScale RRH 2T2R B40 120 W* feature is impacted by the following features:

- *LTE614: Distributed Site.* With this feature, AZND/AZNE can be used in distributed sites with up to 23 km fiber length.
- With *LTE2541: Nokia CPRI RRH/RFM chaining*, AZND/AZNE supports Nokia CPRI chain of up to four radio units.
- Power saving features:
 - *LTE1103: Load based Power Saving for multi-layer networks*
 - *LTE1203: Load based Power Saving with Tx path switching off*
 - *LTE2508: BTS Embedded Power Meter for Energy Efficiency Monitoring*
 - *LTE3036: Micro DTX extension*

7.2 Nokia AirScale RRH 4T4R B40/n40 160 W (AZNA)

AZNA is introduced by *LTE2810/5GC002361: Nokia AirScale RRH 4T4R B40/n40 160 W (AZNA)*.

Functional description

Table 516 AZNA functional specification

Property	Value
Output power	4x40 W
Output power of the cell per TX	30 to 46 dBm
QAM	256 QAM (DL) 64 QAM (UL)
Number of TXRX	4T4R
Outdoor installation	Yes
Beamforming	No
Supported technologies (standalone and MSR)	TD-LTE, 5G NR
Frequency range	2300 - 2400 MHz
Filter bandwidth	100 MHz
iBW (instantaneous bandwidth)	100 MHz
oBW (occupied bandwidth)	80 MHz
Number of carriers per pipe	Up to 4
Supported bandwidths	5, 10, 15, 20 MHz

Interfaces

Figure 148 AZNA interfaces

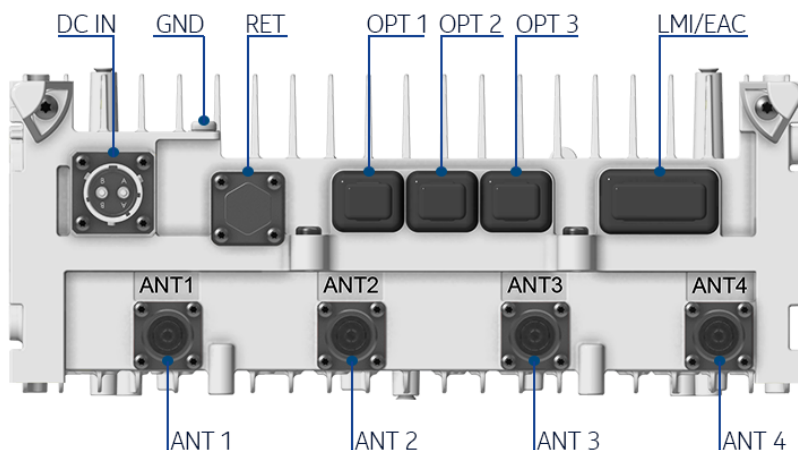



Table 517 AZNA interfaces

Interface	Label on the HW	Number of interfaces	Connector type	Additional info
Power Connector	DC IN	1	High power circular	APPB, APPC
Antenna connector	ANT	4	4.3-10	-
AISG Connector	RET	1	8-pin circular	RS-485
External Alarm Connection / Local Management Interface	EAC	1	MDR26	4 alarm inputs and 1 control output
Optical interface	OPT	3	SFP+	9.8 Gbps, CPRI; Nokia IP seal
Grounding		1	2 x M5 screw or 1 x M8 screw	-
Fan	FAN	1	Nokia fan	Located on the opposite side



WARNING! Risk of electric shock

Before turning RF power on, RF ports have to be terminated by nominal 50Ω load (for example, feeder with antenna). However, if these conditions are not met, the plastic caps that are delivered within the unused RF ports should remain in place. The plastic caps isolate RF power from the environment, and thus provide electric shock security in case RF power is accidentally on.

Antenna Line Devices (ALDs) support

Table 518 AZNA ALD support

ALD support	Value
AISG	ANT1, ANT3: AISG2.0/3.0* RET: AISG 2.0/3.0
CWA (for non-AISG installations)	No
Voltage	ANT1, ANT3: 14.5 V* RET: 14.5 V
Power per port	ANT1, ANT3: 45 W* RET port: 45 W

*ALDs are supported on ANT ports only in versions A.101, A.102, and B.

Functional block diagram

AZNA has two variants, for various ALD functions:

- Versions A.101, A.102, and all B-versions support ALD through both RET and ANT ports
- Versions A.203 and later support ALD only through RET ports

Figure 149 AZNA (with MHA) variants A.101, A.102, all B-variants; functional block diagram

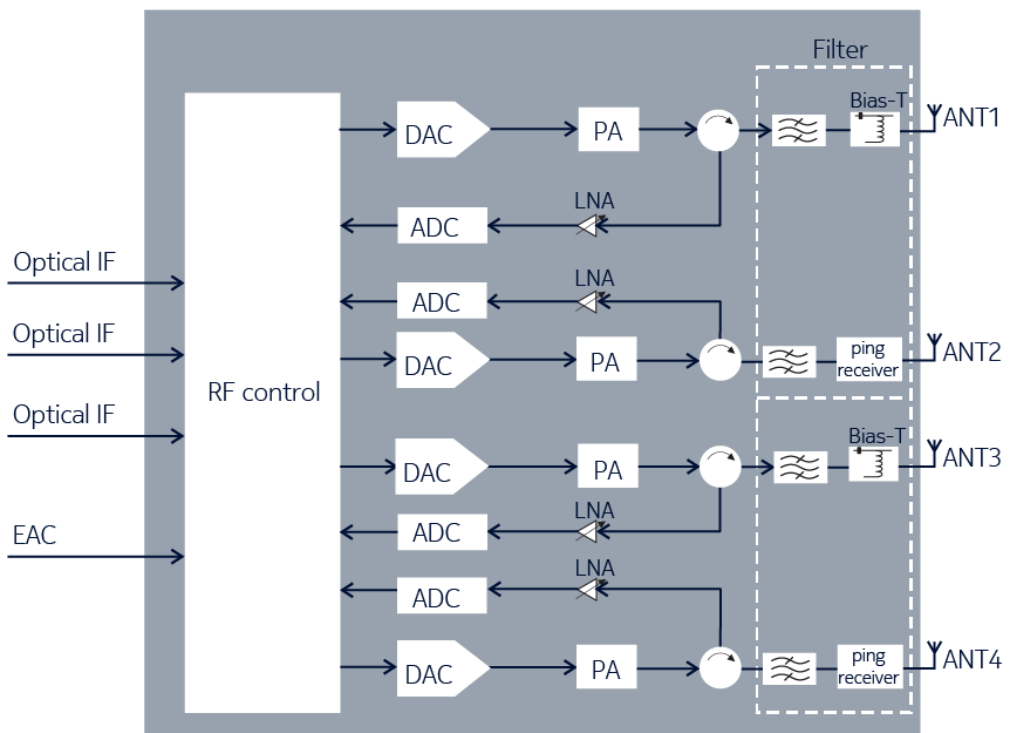
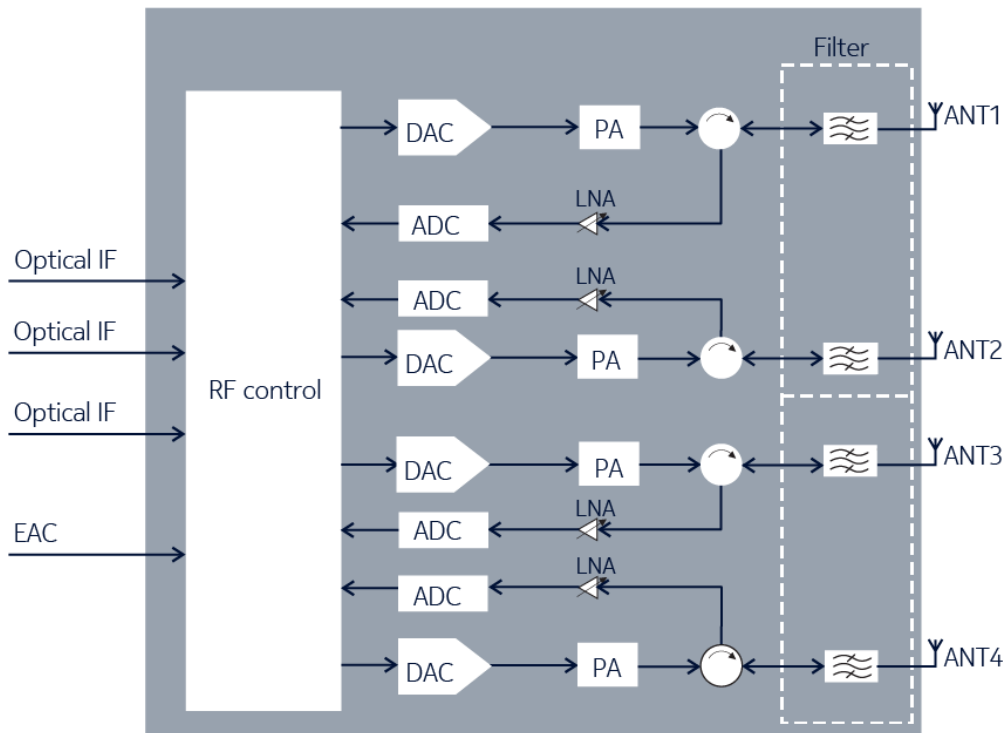

Figure 150 AZNA (without MHA) variants A.203 onwards; functional block diagram



Electrical specifications

Table 519 AZNA electrical specifications

Property	Value
Nominal supply voltage	-48.0 V DC
Nominal input voltage range	-40.5 V DC to -57.0 V DC
Extended input voltage range	-36.0 V DC to -40.5 V DC -57.0 V DC to -60.0 V DC



Note: The minimum startup voltage is -40.5 V DC. If the input voltage is below/beyond extended limits, unit might shut down.

Power consumption

Typical power consumption [W] for 48VDC input, at 25°C, representative of typical product performance under the same conditions (HW variant, SW version, configuration, environment, and so on) with +/- 10% margin. Average = (6h low hour load, 10h medium hour load and 8h busy hour load) / 24h

Configurations explained on examples:

- GSM/WCDMA: 2/2/2 = three sectors, two carriers/TRXs per sector
- LTE:
 - o 2/2/2 2Tx = three sectors, two carriers per sector, 2Tx per carrier
 - o 1+1/1+1/1+1 4Tx = three dual-band sectors, one carrier per sector per band, 4Tx per carrier

Some radio units are capable of providing only one sector coverage. Then the power values in the table consider deployment of three radio units.

Table 520 AZNA power consumption in LTE mode

Configuration	Output power per carrier [W]	Power consumption ETSI 202706 average load $P_{RRH, static}$	Power consumption ETSI 202706 busy hour load $P_{BH, RRH, static}$	Power consumption 100% RF power load $P_{100\% RRH}$
1/1/1 2Tx	2x40	435	519	708
1/1/1 4Tx	4x40	682	857	1272
1/1/1 2Tx	2x20	368	415	507
1/1/1 4Tx	4x20	546	643	834
1/1/1 2Tx	2x10	331	360	409
1/1/1 4Tx	4x10	468	528	631



Note: Power consumption values are measured according to ETSI 202 706-1 v1.5 assumptions (subframe #2 and special subframe #7), leading to 74.3% TX duty cycle. Higher TX duty cycle causes higher power consumption.

Power reduction

Table 521 Recommended AZNA power reduction in 256 QAM

Carrier configuration	Power reduction [dB]
Multiple carriers, continuous	1.2
Multiple carriers, non-continuous	1.5
Single carrier	0.9



Note: The maximum power reduction (`dlCellPwrRed`) value is 20 dB. High power reduction values may cause radio outages.

Related optional items

- ASFB AirScale 2 TD RRH 4-pipe fan unit (474483A)
- APAA AirScale AC-DC Power Unit 760W (473936A)
- AMAA AirScale 2 casing for RRH aux-units (474141A):
 - APAC AirScale AC PDU 1 to 3 (474142A)
 - APAA AirScale AC-DC Power Unit 760W (473936A) - maximum three units per one AMAA
- AMGC AirScale 2 cover 300 x 101-125 (474269A)
- AMBE AirScale book mount kit 101-125 (474277A)
- FPKA Flexi Pole Mounting Kit (30-120 mm) (471649A)
- FPKC Flexi Pole Mounting Kit (60-300 mm) (472821A)
- AMPA Pole Mounting Kit (30-120 mm) (473879A)
- AMFA AirScale 2 FPKx fixing adapter (474289A)
- AMFB AirScale 2 RAS 2.0 fixing kit 300 mm (474290A)

- AMFC AirScale 2 19" rack fixing 300 (474291A)
- AMRA AirScale one clip bracket 51-125 (474580A)
- AMRC AirScale one clip rail 600 mm (474583A)
- ASAA AirScale 2 MDR26-open EAC cable 5 m (474288A)
- APPB AirScale 2 55A DC plug 3.3-10 mm² (474282A)
- APPC AirScale 2 55A DC plug 10-16 mm² (474283A)

Installation options

- Pole installation
- Wall installation
- Tower installation
- Book mounting
- RAS compatibility
- One-clip rail installation



NOTICE: Install this RRH in a vertical orientation with connectors on the bottom side, to ensure convection cooling. For horizontal installation fans are required.

Dimensions and weight

Table 522 AZNA dimensions and weight

Property	Value	Dimensions orientation
Height	Core RRH: 336 mm (13.2 in.) With upper and lower mounting brackets: 427.5 mm (16.8 in.)	
Depth	Core RRH: 120 mm (4.7 in.) With mounting brackets: 144 mm (5.7 in.)	
Width	300 mm (11.8 in.)	
Weight	11 kg (24.3 lb)	
Volume	12.1 l	

Environmental specifications

Table 523 AZNA environmental specifications

Property	Value
Maximum operational outdoor temperature (in the shade)	55°C (131°F)
Maximum operational outdoor temperature (in the sun)	55°C (131°F)
Maximum indoor temperature	45°C (113°F)
Minimum operational temperature	-40°C (-40°F)
IP rating	IP65

LTE2810 feature interdependencies

LTE2810: AZNA AirScale RRH 4T4R B40 160 W supports the following features:

- *LTE112: Cell Bandwidth - 20 MHz* enables LTE 20 MHz carriers.
- *LTE113: Cell Bandwidth - 15 MHz* enables LTE 15 MHz carriers.
- *LTE114: Cell Bandwidth - 10 MHz* enables LTE 10 MHz carriers.
- *LTE115: Cell Bandwidth - 5 MHz* enables LTE 5 MHz carriers.
- *LTE3036: Micro DTX extension*
- *LTE2508: BTS Embedded Power Meter for Energy Efficiency Monitoring*
- *LTE1103: Load based Power Saving for multi-layer networks*
- *LTE1203: Load based Power Saving with Tx path switching off*

7.3 Nokia AirScale RRH 4T4R B41/n41 160 W (AZHA)

AZHA is introduced by LTE3329/5GC002400: Nokia AirScale RRH 4T4R B41/n41 160 W (AZHA).

Functional description

Table 524 AZHA functional specification

Property	Value
Output power	4x40 W
Output power of the cell per TX	30 to 46 dBm
QAM	256 QAM (DL) 64 QAM (UL)
Number of TXRX	4T4R
Outdoor installation	Yes
Beamforming	No
Supported technologies (standalone and MSR)	TD-LTE, 5G NR
Frequency range	2496 - 2690 MHz
Filter bandwidth	194 MHz
iBW (instantaneous bandwidth)	194 MHz
oBW (occupied bandwidth)	80 MHz
Number of carriers per pipe	Up to 4
Supported bandwidths	5, 10, 15, 20 MHz

Interfaces

Figure 151 AZHA interfaces

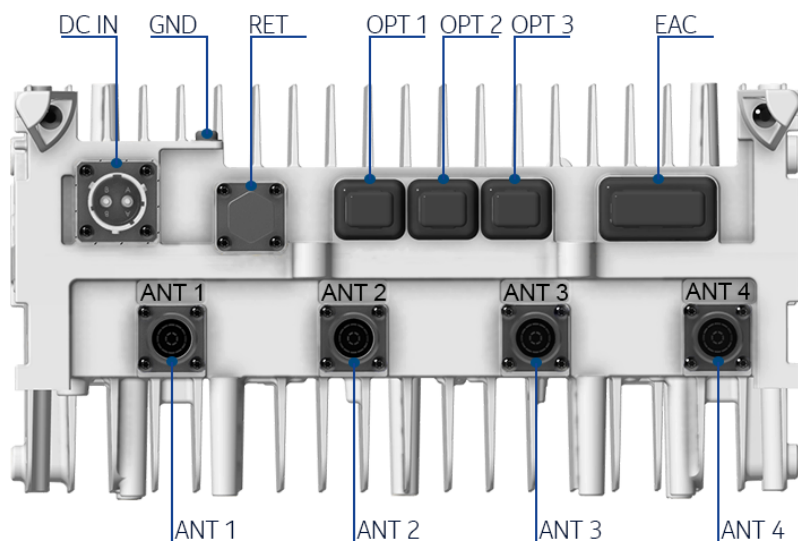

Table 525 AZHA interfaces

Interface	Label on the HW	Number of interfaces	Connector type	Additional info
Power Connector	DC IN	1	High power circular	APPB, APPC
Antenna connector	ANT	4	4.3-10	-
AISG Connector	RET	1	8-pin circular	-
External Alarm Connection / Local Management Interface	EAC	1	MDR26	4 alarm inputs and 1 control output
Optical interface	OPT	3	SFP+	9.8 Gbps, CPRI; Nokia IP seal
Grounding		1	2 x M5 screw or 1 x M8 screw	-
Fan	FAN	1	Nokia fan	Located on the opposite side



WARNING! Risk of electric shock

Before turning RF power on, RF ports have to be terminated by nominal 50Ω load (for example, feeder with antenna). However, if these conditions are not met, the plastic caps that are delivered within the unused RF ports should remain in place. The plastic caps isolate RF power from the environment, and thus provide electric shock security in case RF power is accidentally on.

Antenna Line Devices (ALDs) support

Table 526 AZHA ALD support

ALD support through RS-485 port	Value
AISG	ANT1, ANT3, RET: AISG 2.0/3.0 ANT2, ANT4: AISG 3.0 Ping Receiver
CWA (for non-AISG installations)	No
Voltage	14.5 V
Power per port	40 W RET port: 30 W

Functional block diagram

Figure 152 AZHA functional block diagram

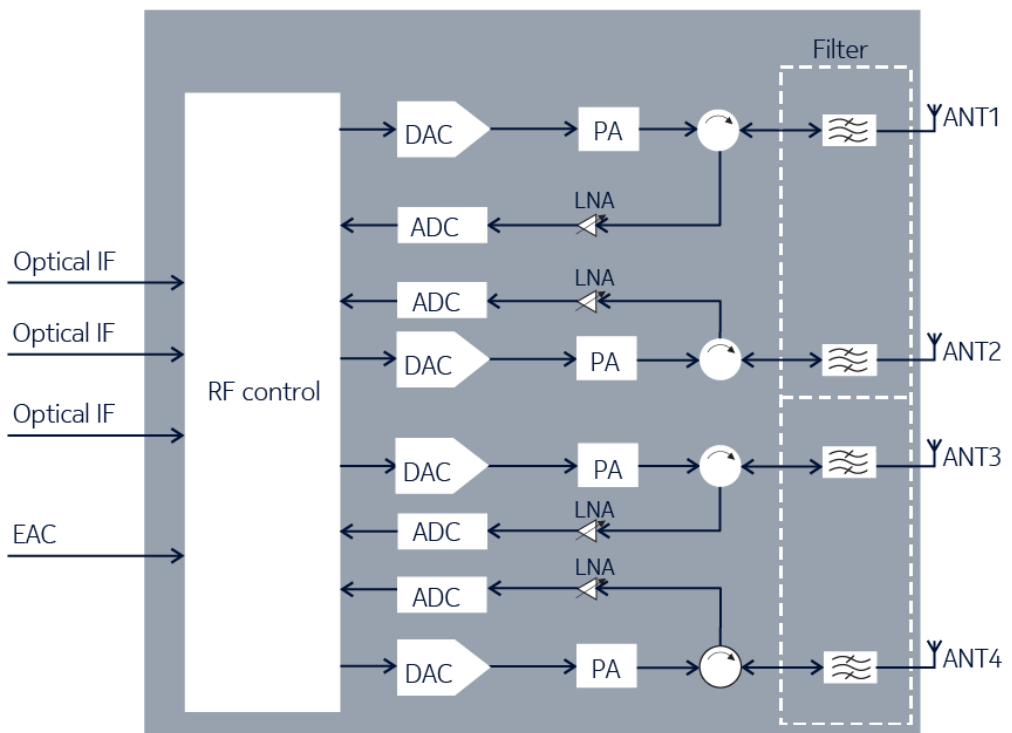

Electrical specifications

Table 527 AZHA electrical specifications

Property	Value
Nominal supply voltage	-48.0 V DC
Nominal input voltage range	-40.5 V DC to -57.0 V DC
Extended input voltage range	-36.0 V DC to -40.5 V DC -57.0 V DC to -60.0 V DC



Note: The minimum startup voltage is -40.5 V DC. If the input voltage is below/beyond extended limits, unit might shut down.

Power consumption

Typical power consumption [W] for 48VDC input, at 25°C, representative of typical product performance under the same conditions (HW variant, SW version, configuration, environment, and so on) with +/- 10% margin. Average = (6h low hour load, 10h medium hour load and 8h busy hour load) / 24h

Configurations explained on examples:

- GSM/WCDMA: 2/2/2 = three sectors, two carriers/TRXs per sector
- LTE:
 - o 2/2/2 2Tx = three sectors, two carriers per sector, 2Tx per carrier
 - o 1+1/1+1/1+1 4Tx = three dual-band sectors, one carrier per sector per band, 4Tx per carrier

Some radio units are capable of providing only one sector coverage. Then the power values in the table consider deployment of three radio units.

Table 528 AZHA power consumption in LTE mode

Configuration	Output power per carrier [W]	Power consumption ETSI 202706 average load P _{RRH, static}	Power consumption ETSI 202706 busy hour load P _{BH RRH, static}	Power consumption 100% RF power load P _{100% RRH}
1/1/1 2Tx	2x10	342	375	427
1/1/1 2Tx	2x20	383	435	524
1/1/1 2Tx	2x40	579	692	885
1/1/1 4Tx	4x10	490	561	672
1/1/1 4Tx	4x20	452	539	717
1/1/1 4Tx	4x40	734	929	1339



Note: Power consumption values are measured according to ETSI 202 706-1 v1.5 assumptions (subframe #2 and special subframe #7), leading to 74.3% TX duty cycle. Higher TX duty cycle causes higher power consumption.

Power reduction



Note: The maximum power reduction (dlCellPwrRed) value is 20 dB. High power reduction values may cause radio outages.

Related optional items

- ASFB AirScale 2 TD RRH 4-pipe fan unit (474483A)
- APAA AirScale AC-DC Power Unit 760W (473936A)
- AMAA AirScale 2 casing for RRH aux-units (474141A):
 - APAC AirScale AC PDU 1 to 3 (474142A)

- APAA AirScale AC-DC Power Unit 760W (473936A) - maximum three units per one AMAA
- AMGE AirScale 2 cover 300 x 151-175 (474271A)
- AMBG AirScale book mount kit 151-175 (474467A)
- FPKA Flexi Pole Mounting Kit (30-120 mm) (471649A)
- FPKC Flexi Pole Mounting Kit (60-300 mm) (472821A)
- AMPA Pole Mounting Kit (30-120 mm) (473879A)
- AMFA AirScale 2 FPKx fixing adapter (474289A)
- AMFB AirScale 2 RAS 2.0 fixing kit 300 mm (474290A)
- AMFC AirScale 2 19" rack fixing 300 (474291A)
- AMRB AirScale one clip bracket 126-200 (474581A)
- AMRC AirScale one clip rail 600 mm (474583A)
- ASAA AirScale 2 MDR26-open EAC cable 5 m (474288A)
- APPB AirScale 2 55A DC plug 3.3-10 mm² (474282A)
- APPC AirScale 2 55A DC plug 10-16 mm² (474283A)

Installation options

- Pole installation
- Wall installation
- Tower installation
- Book mounting
- RAS compatibility
- One-clip rail installation



NOTICE: Install this RRH in a vertical orientation with connectors on the bottom side, to ensure convection cooling. For horizontal installation fans are required.

Dimensions and weight

Table 529 AZHA dimensions and weight

Property	Value	Dimensions orientation
Height	Core RRH: 336 mm (13.2 in.) With upper and lower mounting brackets: 427.5 mm (16.8 in.)	
Depth	Core RRH: 155 mm (6.1 in.) With mounting brackets: 178.7 mm (7 in.)	
Width	300 mm (11.8 in.)	
Weight	13 kg (28.7 lb)	
Volume	15.6 l	

Environmental specifications

Table 530 AZHA environmental specifications

Property	Value
Maximum operational outdoor temperature (in the shade)	55°C (131°F)
Maximum operational outdoor temperature (in the sun)	55°C (131°F)
Maximum indoor temperature	45°C (113°F)
Minimum operational temperature	-40°C (-40°F)
IP rating	IP65

LTE3329 feature interdependencies

LTE3329: AZHA AirScale RRH B41 160 W supports the following features:

- *LTE112: Cell Bandwidth - 20 MHz* enables LTE 20 MHz carriers.
- *LTE113: Cell Bandwidth - 15 MHz* enables LTE 15 MHz carriers.
- *LTE114: Cell Bandwidth - 10 MHz* enables LTE 10 MHz carriers.
- *LTE115: Cell Bandwidth - 5 MHz* enables LTE 5 MHz carriers.
- With *LTE614: Distributed Site* AZHA can be used in distributed sites with up to 23 km fiber length to the system module.
- *LTE3036: Micro DTX extension*
- *LTE2508: BTS Embedded Power Meter for Energy Efficiency Monitoring*
- *LTE1103: Load based Power Saving for multi-layer networks*
- *LTE1203: Load based Power Saving with Tx path switching off*

7.4 Nokia AirScale RRH 8T8R B40 240 W (AZNB)

AZNB is introduced by LTE3549: Nokia AirScale RRH 8T8R B40 240 W (AZNB).

Functional description

Table 531 AZNB functional specification

Property	Value
Output power	8x30 W
QAM	256 QAM (DL) 64 QAM (UL)
Number of TXRX	8T8R
Outdoor installation	Yes
Beamforming	Yes
Supported technologies (standalone and MSR)	TD-LTE
Frequency range	2300-2400 MHz
Filter bandwidth	100 MHz

Table 531 AZNB functional specification (Cont.)

Property	Value
iBW (instantaneous bandwidth)	100 MHz
oBW (occupied bandwidth)	80 MHz
Number of carriers per pipe	Up to 4
Supported bandwidths	10, 15, 20 MHz

Interfaces

Figure 153 AZNB interfaces

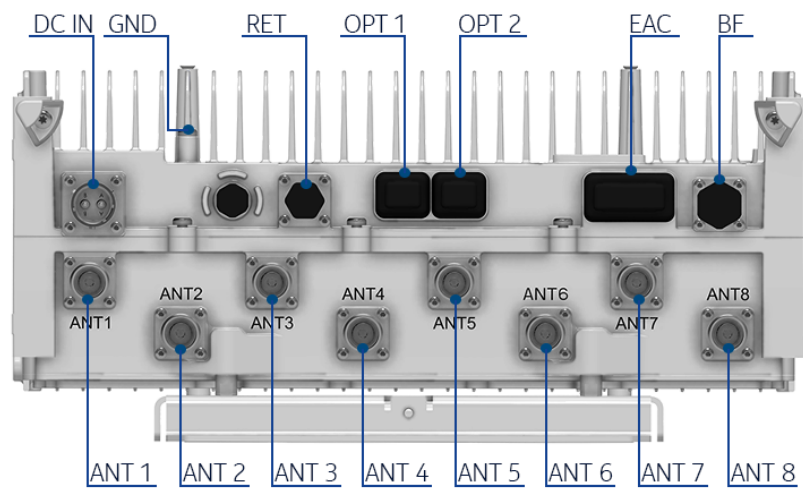

Table 532 AZNB interfaces

Interface	Label on the HW	Number of interfaces	Connector type	Additional info
Power Connector	DC IN	1	High power circular	APPB, APPC
Antenna connector	ANT	8	4.3-10	-
Remote Electrical Tilt	RET	1	8-pin circular	RS-485
External Alarm Connection	EAC	1	MDR26	-
Optical interface	OPT	2	SFP+	9.8 Gbps, CPRI; Nokia IP seal
Beamforming	BF	1	4.3-10	-
Grounding	GND	1	2 x M5 screw	-

Table 532 AZNB interfaces (Cont.)

Interface	Label on the HW	Number of interfaces	Connector type	Additional info
Fan	FAN	1	Nokia fan	Located on the opposite side



WARNING! Risk of electric shock

Before turning RF power on, RF ports have to be terminated by nominal 50Ω load (for example, feeder with antenna). However, if these conditions are not met, the plastic caps that are delivered within the unused RF ports should remain in place. The plastic caps isolate RF power from the environment, and thus provide electric shock security in case RF power is accidentally on.

Antenna Line Devices (ALDs) support

Table 533 AZNB ALD support

ALD support through RS-485 port	Value
AISG	3.0 Main only
CWA (for non-AISG installations)	No
Voltage	14.5 V Main only
Power per port	30 W

Functional block diagram

Figure 154 AZNB functional block diagram

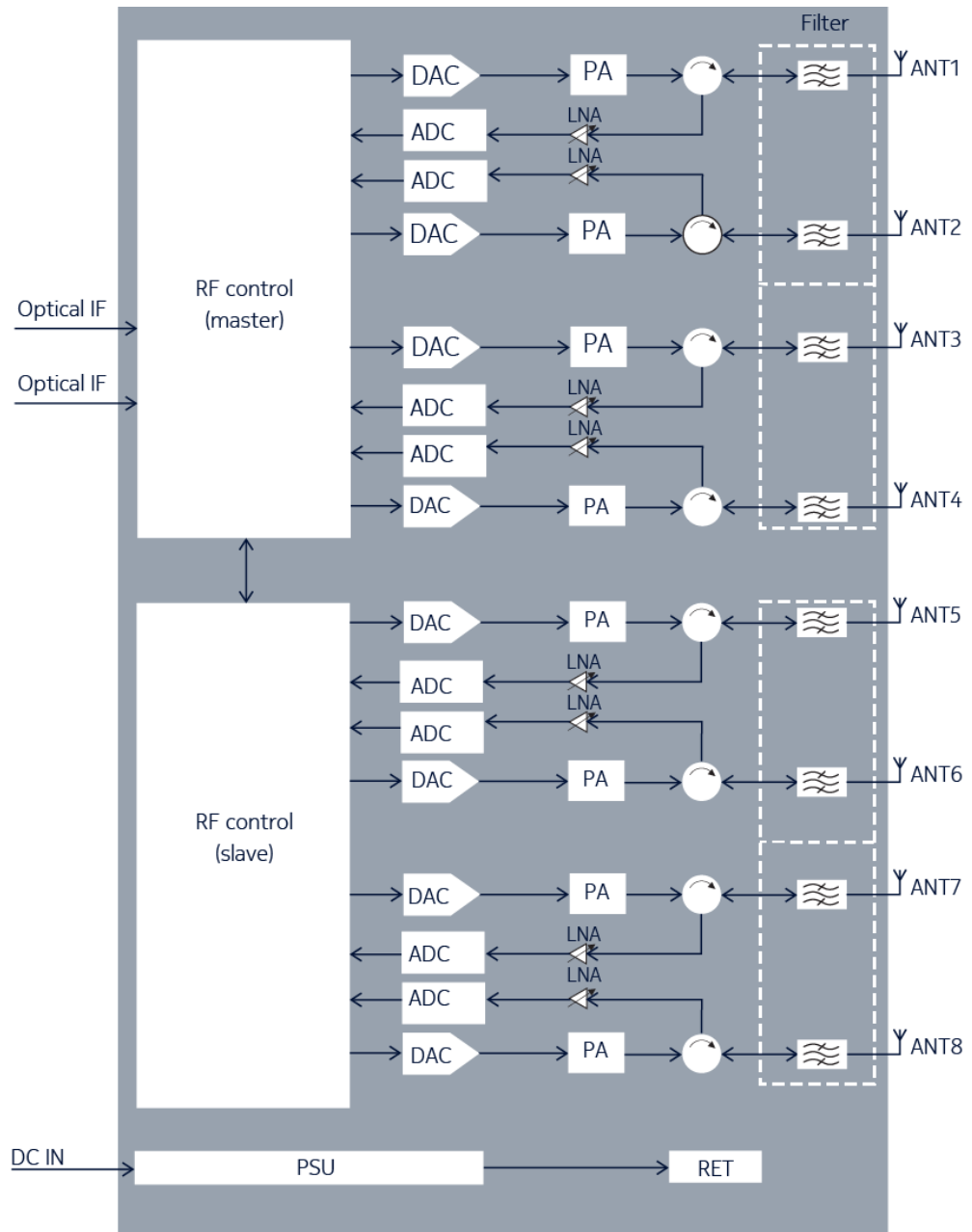

Electrical specifications

Table 534 AZNB electrical specifications

Property	Value
Nominal supply voltage	-48.0 V DC
Nominal input voltage range	-40.5 V DC to -57.0 V DC
Extended input voltage range	-36.0 V DC to -40.5 V DC -57.0 V DC to -60.0 V DC



Note: The minimum startup voltage is -40.5 V DC. If the input voltage is below/beyond extended limits, unit might shut down.

Power consumption

Typical power consumption [W] for 48VDC input, at 25°C, representative of typical product performance under the same conditions (HW variant, SW version, configuration, environment, and so on) with +/- 10% margin. Average = (6h low hour load, 10h medium hour load and 8h busy hour load) / 24h

Configurations explained on examples:

- GSM/WCDMA: 2/2/2 = three sectors, two carriers/TRXs per sector
- LTE:
 - o 2/2/2 2Tx = three sectors, two carriers per sector, 2Tx per carrier
 - o 1+1/1+1/1+1 4Tx = three dual-band sectors, one carrier per sector per band, 4Tx per carrier

Some radio units are capable of providing only one sector coverage. Then the power values in the table consider deployment of three radio units.

Table 535 AZNB power consumption in LTE mode

Configuration	Output power per carrier [W]	Power consumption ETSI 202706 average P _{RRH} , static	Power consumption ETSI 202706 busy hour load P _{BH RRH} , static	Power consumption 100% RF power load P _{100% RRH}
1/1/1 8Tx	8x30	1031	1274	1824
1/1/1 4Tx	4x30	653	770	1018
1/1/1 8Tx	8x20	895	1046	1400
1/1/1 4Tx	4x20	589	664	834



Note: Power consumption values are measured according to ETSI 202 706-1 v1.5 assumptions (subframe #2 and special subframe #7), leading to 74.3% TX duty cycle. Higher TX duty cycle causes higher power consumption.

Power reduction

Table 536 Recommended AZNB power reduction in 256 QAM

Carrier configuration	Power reduction [dB]
Multiple carriers, continuous	1.5
Multiple carriers, non-continuous	2
Single carrier	1



Note: The maximum power reduction (dlCellPwrRed) value is 20 dB. High power reduction values may cause radio outages.

Related optional items

- ASFD AirScale 2 TD RRH 8-pipe fan unit (474485A)

- AMGN AirScale 2 cover 395 x 150-175 (474535A)
- AMBG AirScale bookmount kit 151-175 (474467A)
- FPKA Flexi Pole Mounting Kit (30-120 mm) (471649A)
- FPKC Flexi Pole Mounting Kit (60-300 mm) (472821A)
- AMPA Pole Mounting Kit (30-120 mm) (473879A)
- AMFA AirScale 2 FPKx fixing adapter (474289A)
- AMRB AirScale one clip bracket 126-200 (474581A)
- AMRC AirScale one clip rail 600 mm (474583A)
- ASAA AirScale 2 MDR26-open EAC cable 5 m (474288A)
- APPB AirScale 2 55A DC plug 3.3-10 mm² (474282A)
- APPC AirScale 2 55A DC plug 10-16 mm² (474283A)

Installation options

- Pole installation
- Wall installation
- Book mounting with optional fan
- RAS compatibility
- One-clip rail installation



NOTICE: Install this RRH in a vertical orientation with connectors on the bottom side, to ensure convection cooling. For horizontal installation fans are required.

Dimensions and weight

Table 537 AZNB dimensions and weight

Property	Value	Dimensions orientation
Height	385 mm (15.2 in.) With upper and lower mounting brackets: 469 mm (18.5 in.)	
Depth	160 mm (6.3 in.) With mounting brackets: 185.5 mm (7.3 in.)	
Width	395 mm (15.6 in.)	
Weight	22 kg (48.5 lb)	

Environmental specifications

Table 538 AZNB environmental specifications

Property	Value
Maximum operational outdoor temperature (in the shade)	55°C (131°F)
Maximum operational outdoor temperature (in the sun)	55°C (131°F)

Table 538 AZNB environmental specifications (Cont.)

Property	Value
Maximum indoor temperature	45°C (113°F)
Minimum operational temperature	-40°C (-40°F)
IP rating	IP65

LTE3549 feature interdependencies

LTE3549:AirScale RRH 8T8R B40 240 W (AZNB) supports the following features:

- LTE112: Cell Bandwidth - 20 MHz enables LTE 20 MHz carriers.
- LTE113: Cell Bandwidth - 15 MHz enables LTE 15 MHz carriers.
- LTE114: Cell Bandwidth - 10 MHz enables LTE 10 MHz carriers.
- With LTE 614: Distributed Site AZNB can be used in distributed sites with up to 23km fiber length to the system module.
- Power saving features:
 - LTE1103: Load based Power Saving for multi-layer networks
 - LTE1203: Load based Power Saving with Tx path switching off
 - LTE2508: BTS Embedded Power Meter for Energy Efficiency Monitoring
 - LTE3036: Micro DTX extension

7.5 Nokia AirScale RRH 8T8R B40 240 W (AZNC)

AZNC is introduced by LTE3550: Nokia AirScale RRH 8T8R B40 240 W (AZNC).

Functional description

Table 539 AZNC functional specification

Property	Value
Output power	8x30 W
QAM	256 QAM (DL) 64 QAM (UL)
Number of TXRX	8T8R
Outdoor installation	Yes
Beamforming	Yes
Supported technologies (standalone and MSR)	TD-LTE
Frequency range	2350 - 2390 MHz
Filter bandwidth	40 MHz
iBW (instantaneous bandwidth)	40 MHz
oBW (occupied bandwidth)	40 MHz
Number of carriers per pipe	Up to 2

Table 539 AZNC functional specification (Cont.)

Property	Value
Supported bandwidths	10, 15, 20 MHz

Interfaces

Figure 155 AZNC interfaces

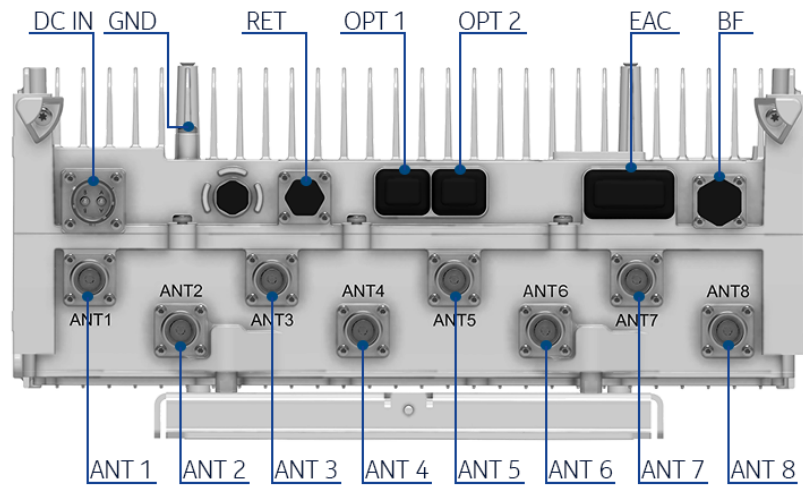

Table 540 AZNC interfaces

Interface	Label on the HW	Number of interfaces	Connector type	Additional info
Power Connector	DC IN	1	High power circular	APPB, APPC
Antenna connector	ANT	8	4.3-10	-
Remote Electrical Tilt	RET	1	8-pin circular	RS-485
External Alarm Connection	EAC	1	MDR26	-
Optical interface	OPT	2	SFP+	9.8 Gbps, CPRI; Nokia IP seal
Beamforming	BF	1	4.3-10	-
Grounding		1	2 x M5 screw	-
Fan	FAN	1	Nokia fan	Located on the opposite side



WARNING! Risk of electric shock

Before turning RF power on, RF ports have to be terminated by nominal 50Ω load (for example, feeder with antenna). However, if these conditions are not met, the plastic caps that are delivered within the unused RF ports should remain in place. The plastic caps isolate RF power from the environment, and thus provide electric shock security in case RF power is accidentally on.

Antenna Line Devices (ALDs) support

Table 541 AZNC ALD support

ALD support through RS-485 port	Value
AISG	2.0
CWA (for non-AISG installations)	No
Voltage	14.5 V
Power per port	30 W

Functional block diagram

Figure 156 AZNC functional block diagram

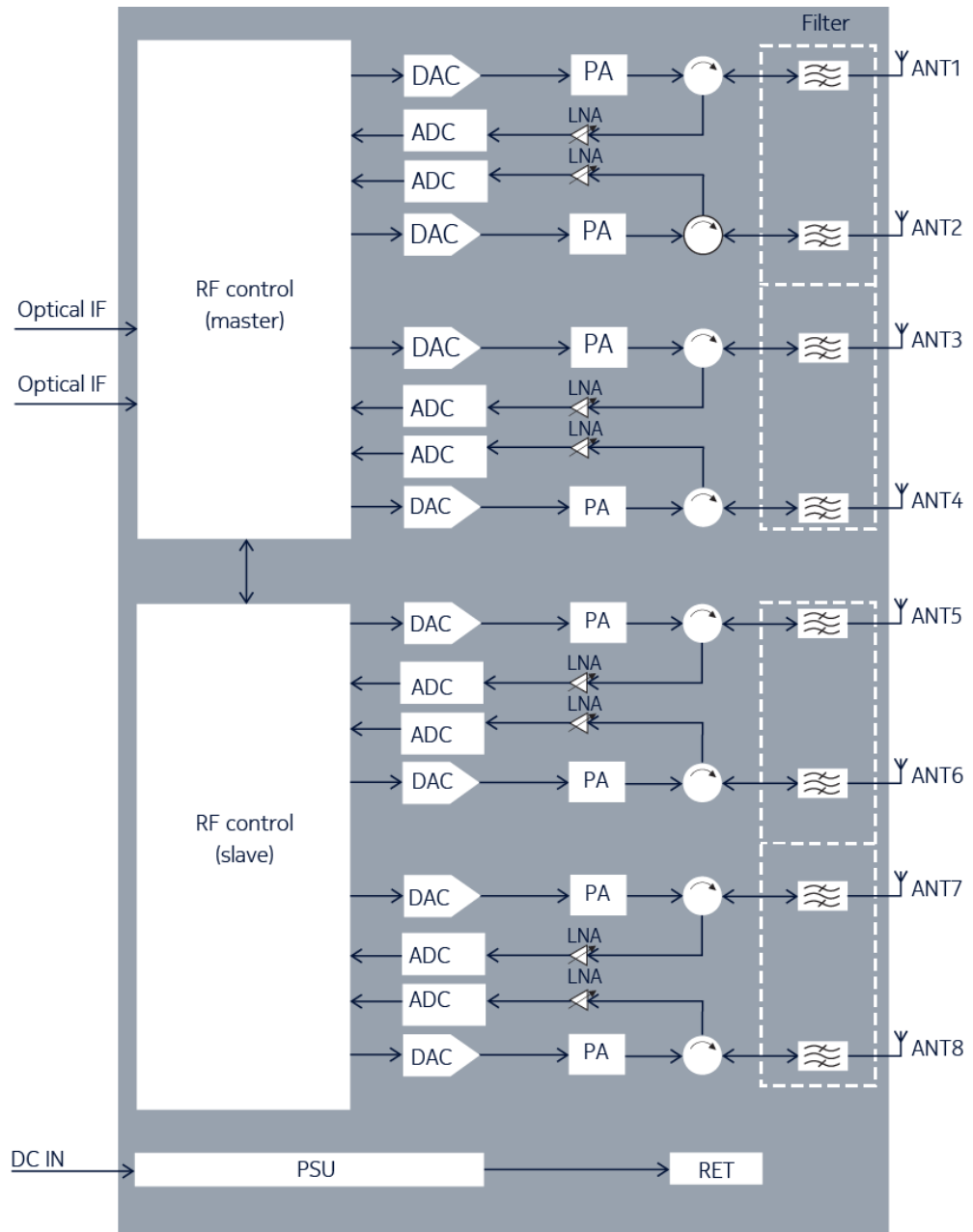

Electrical specifications

Table 542 AZNC electrical specifications

Property	Value
Nominal supply voltage	-48.0 V DC
Nominal input voltage range	-40.5 V DC to -57.0 V DC
Extended input voltage range	-36.0 V DC to -40.5 V DC -57.0 V DC to -60.0 V DC



Note: The minimum startup voltage is -40.5 V DC. If the input voltage is below/beyond extended limits, unit might shut down.

Power consumption

Typical power consumption [W] for 48VDC input, at 25°C, representative of typical product performance under the same conditions (HW variant, SW version, configuration, environment, and so on) with +/- 10% margin. Average = (6h low hour load, 10h medium hour load and 8h busy hour load) / 24h

Configurations explained on examples:

- GSM/WCDMA: 2/2/2 = three sectors, two carriers/TRXs per sector
- LTE:
 - o 2/2/2 2Tx = three sectors, two carriers per sector, 2Tx per carrier
 - o 1+1/1+1/1+1 4Tx = three dual-band sectors, one carrier per sector per band, 4Tx per carrier

Some radio units are capable of providing only one sector coverage. Then the power values in the table consider deployment of three radio units.

Table 543 AZNC power consumption in LTE mode

Configuration	Output power per carrier [W]	Power consumption ETSI 102706 average P _{RRH} , static	Power consumption ETSI 102706 busy hour load P _{BH RRH} , static	Power consumption 100% RF power load P _{100% RRH}
1/1/1 8Tx	8 x 30	1029	1280	1820
1/1/1 4Tx	4 x 30	653	775	1030
1/1/1 8Tx	8 x 20	897	1058	1419
1/1/1 4Tx	4 x 20	591	671	847



Note: Power consumption values are measured according to ETSI 202 706-1 v1.5 assumptions (subframe #2 and special subframe #7), leading to 74.3% TX duty cycle. Higher TX duty cycle causes higher power consumption.

Power reduction

Table 544 Recommended AZNC power reduction in 256 QAM

Carrier configuration	Power reduction [dB]
Continuous	1.5
Non-continuous	2



Note: The maximum power reduction (dlCellPwrRed) value is 20 dB. High power reduction values may cause radio outages.

Related optional items

- ASFD AirScale 2 TD RRH 8-pipe fan unit (474485A)
- AMGN AirScale 2 cover 395 x 150-175 (474535A)

- AMBG AirScale bookmount kit 151-175 (474467A)
- FPKA Flexi Pole Mounting Kit (30-120 mm) (471649A)
- FPKC Flexi Pole Mounting Kit (60-300 mm) (472821A)
- AMPA Pole Mounting Kit (30-120 mm) (473879A)
- AMFA AirScale 2 FPKx fixing adapter (474289A)
- AMRB AirScale one clip bracket 126-200 (474581A)
- AMRC AirScale one clip rail 600 mm (474583A)
- ASAA AirScale 2 MDR26-open EAC cable 5 m (474288A)
- APPB AirScale 2 55A DC plug 3.3-10 mm² (474282A)
- APPC AirScale 2 55A DC plug 10-16 mm² (474283A)

Installation options

- Pole mounting
- Wall mounting
- Tower mounting
- Book mounting with optional fan
- One-clip rail installation



NOTICE: Install this RRH in a vertical orientation with connectors on the bottom side, to ensure convection cooling. For horizontal installation fans are required.

Dimensions and weight

Table 545 AZNC dimensions and weight

Property	Value	Dimensions orientation
Height	Core RRH: 385 mm (15.2 in.) With upper and lower mounting brackets: 469 mm (18.5 in.)	
Depth	Core RRH: 160 mm (6.3 in.) With mounting brackets: 185.5 mm (7.3 in.)	
Width	395 mm (15.6 in.)	
Weight	max. 22 kg (48.5 lb)	

Environmental specifications

Table 546 AZNC environmental specifications

Property	Value
Maximum operational outdoor temperature (in the shade)	55°C (131°F)
Maximum operational outdoor temperature (in the sun)	55°C (131°F)
Maximum indoor temperature	45°C (113°F)

Table 546 AZNC environmental specifications (Cont.)

Property	Value
Minimum operational temperature	-40°C (-40°F)
IP rating	IP65

LTE3550 feature interdependencies

LTE3550: Nokia AirScale RRH 8T8R B40 240 W supports the following features:

- LTE112: Cell Bandwidth - 20 MHz enables LTE 20 MHz carriers.
- LTE113: Cell Bandwidth - 15 MHz enables LTE 15 MHz carriers.
- LTE114: Cell Bandwidth - 10 MHz enables LTE 10 MHz carriers.
- LTE614: Distributed Site AZNC can be used in distributed sites with up to 23 km fiber length to the system module.
- Power saving features:
 - LTE1103: Load based Power Saving for multi-layer networks
 - LTE1203: Load based Power Saving with Tx path switching off
 - LTE2508: BTS Embedded Power Meter for Energy Efficiency Monitoring
 - LTE3036: Micro DTX extension

7.6 Nokia AirScale RRH 8T8R B42 160 W (AZQP)

AZQP is introduced by LTE5300: AirScale RRH 8T8R B42 160 W AZQP.

Functional description

Table 547 AZQP functional specification

Property	Value
Output power	8x20 W
QAM	256 QAM (DL) 64 QAM (UL)
Number of TXRX	8T8R
Outdoor installation	Yes
Beamforming	Yes
Supported technologies (standalone and MSR)	TD-LTE, 5G
Frequency range	3400–3600 MHz
iBW (instantaneous bandwidth)	200 MHz
oBW (occupied bandwidth)	LTE: 80 MHz
Number of carriers per pipe	Up to 4
Supported bandwidths	LTE: 10, 15, 20 MHz

Interfaces

Figure 157 AZQP interfaces

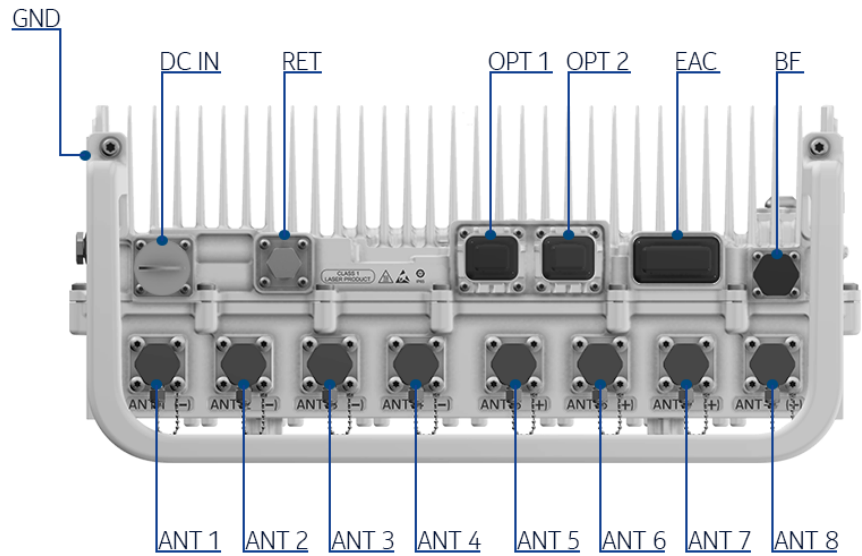



Table 548 AZQP interfaces

Interface	Label on the HW	Number of interfaces	Connector type	Additional info
Power Connector	DC IN	1	High power circular	APPB, APPC
Antenna connector	ANT	8	4.3-10	-
Remote Electrical Tilt	RET	1	8-pin circular	RS-485
External Alarm Connection	EAC	1	MDR26	-
Optical interface	OPT	2	SFP28	CPRI: 9.8 Gbps; Nokia IP seal
Beamforming	BF	1	4.3-10	-
Grounding		1	2 x M5 screw	-
Fan	FAN	1	Nokia fan	Located in fins behind the BF connector
RF Monitor	-	8	SMA, female	Located under each ANT connector



WARNING! Risk of electric shock

Before turning RF power on, RF ports have to be terminated by nominal 50Ω load (for example, feeder with antenna). However, if these conditions are not met, the plastic caps that are delivered within the unused RF ports should remain in place. The plastic caps isolate RF power from the environment, and thus provide electric shock security in case RF power is accidentally on.

Antenna Line Devices (ALDs) support



Note: There is no AISG support on the antenna lines. AISG+DC for RETs is only available through the beamforming calibration port and the RET (RS-485) port.

Table 549 AZQP ALD support

ALD support through RS-485 port	Value
AISG	2.0, 3.0
CWA (for non-AISG installations)	No
Voltage	14.5 V
Power per port	15 W total per unit (2 W ALD modem + 13 W RET)

Functional block diagram

Figure 158 AZQP functional block diagram

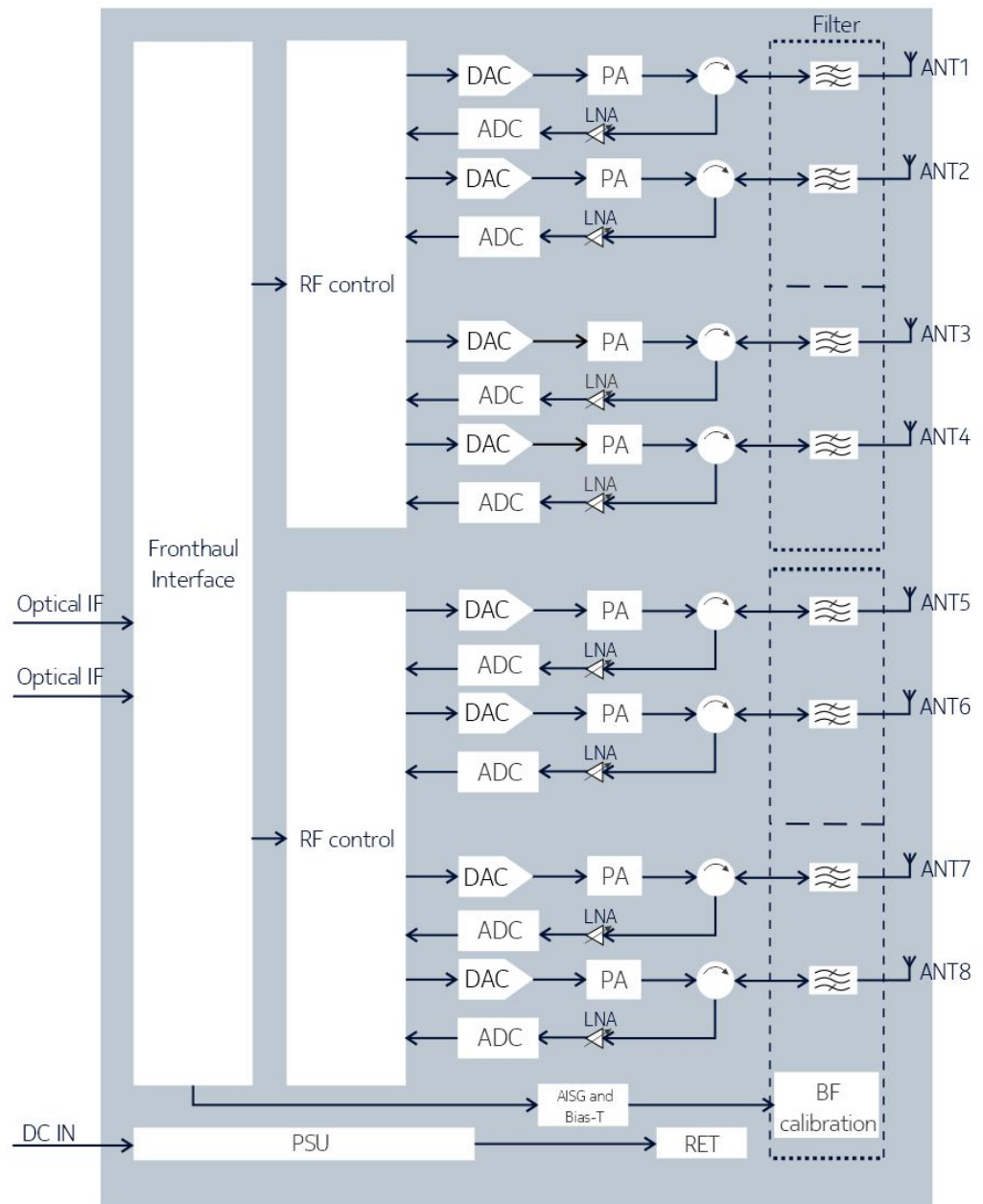

Electrical specifications

Table 550 AZQP electrical specifications

Property	Value
Nominal supply voltage	-48.0 V DC
Nominal input voltage range	-40.5 V DC to -57.0 V DC
Extended input voltage range	-36.0 V DC to -40.5 V DC -57.0 V DC to -60.0 V DC



Note: The minimum startup voltage is -40.5 V DC. If the input voltage is below/beyond extended limits, unit might shut down.

Power consumption



Note: AZQP power consumption will be provided in future releases.

Power reduction



Note: The maximum power reduction (`dlCellPwrRed`) value is 20 dB. High power reduction values may cause radio outages.

Related optional items

- FPKA Flexi Pole Mounting Kit (30-120 mm) (471649A)
- FPKC Flexi Pole Mounting Kit (60-300 mm) (472821A)
- AMPA Pole Mounting Kit (30-120 mm) (473879A)
- AMFD AirScale 2 FPKx Fixing Adapter 600 (474293A)
- AMBQ Book Mounting Kit (475591A)
- AMRB AirScale one clip bracket 126-200 (474581A)
- AMRC AirScale one clip rail 600 mm (474583A)
- ASAC EAC cable MDR26-open 6A+1C 5m (475289A)
- APPB AirScale 2 55A DC plug 3.3-10 mm² (474282A)
- APPC AirScale 2 55A DC plug 10-16 mm² (474283A)
- ACPA AirScale 2 Fiber Protection (474297A)

Installation options

- Pole
- Wall
- Tower mounting
- Book mounting with an optional fan
- One-clip rail installation



NOTICE: Always install this RRH in a vertical orientation with connectors on the bottom side, to ensure convection cooling.

Dimensions and weight

Table 551 AZQP dimensions and weight

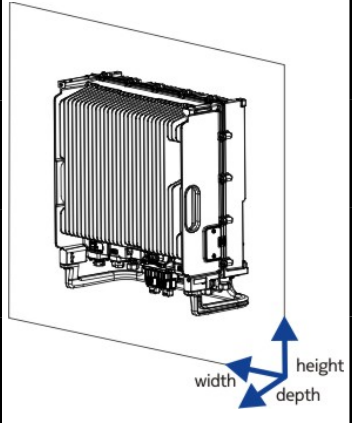
Property	Value	Dimensions orientation
Height	350 mm (13.78 in.)	
Width	395 mm (15.55 in.)	
Depth	165 mm (6.50 in.)	
Weight	Core RRH: 22.1 kg (48.7 lb)	

Environmental specifications

Table 552 AZQP environmental specifications

Property	Value
Maximum operational outdoor temperature (stand-alone outdoor pole or mast)	55°C (131°F)
Maximum operational indoor and outdoor temperature (wall and shelter)	45°C (113°F)
Maximum operational indoor and outdoor temperature (with optional fan)	55°C (131°F)
Minimum operational temperature	-40°C (-40°F)
IP rating	IP65

LTE5300 feature interdependencies

The *LTE5300: AirScale RRH 8T8R B42 160 W AZQP* feature is impacted by the following features:

- *LTE112: Cell Bandwidth - 20 MHz* enables LTE 20 MHz carriers.
- With *LTE614: Distributed Site*, AZQP can be used in distributed sites with up to 23 km (14.29 mi) fiber length to the system module.
- With *LTE2541: Nokia CPRI RRH/RFM chaining*, AZQP supports Nokia CPRI chain of up to four radio units.
- Power saving features:
 - *LTE1103: Load based Power Saving for multilayer networks*
 - *LTE1203: Load based Power Saving mode with TX power reduction or path switching off*
 - *LTE2508: BTS Embedded Power Meter for Energy Efficiency Monitoring*
 - *LTE3036: Micro DTX extension*

7.7 Nokia AirScale RRH 8T8R B42 240 W (AZQE)

AZQE is introduced by LTE3736: Nokia AirScale RRH 8T8R B42 240 W (AZQE)

Functional description

Table 553 AZQE functional specification

Property	Value
Output power	8 x 30 W with continuous carrier configuration 8 x 20 W with non-continuous carrier configuration
QAM	64 QAM / 256 QAM (DL) 64 QAM (UL)
Number of TXRX	8T8R
Outdoor installation	Yes
Beamforming	Yes
Supported technologies (standalone and MSR)	TD-LTE
Frequency range	3400 - 3600 MHz
Filter bandwidth	200 MHz
iBW (instantaneous bandwidth)	<p>140 MHz</p> <p>Carrier configuration depends on the iBW used:</p> <ul style="list-style-type: none"> For iBW up to 110 MHz - any carrier configuration For iBW over 110 MHz and up to 140 MHz the following requirements for carrier blocks must be fulfilled. A carrier block is a set of consecutive carriers. <ul style="list-style-type: none"> The frequency distance between the lower edge of the lowest carrier block and the lower edge of the highest carrier block must be max 100 MHz The frequency distance between the lower edge of the lowest carrier block and the lower edge of the highest carrier block must be max 100 MHz <p><i>Figure 159 AZQE carrier configuration for iBW from over 110 MHz to 140 MHz</i></p>

Table 553 AZQE functional specification (Cont.)

Property	Value
oBW (occupied bandwidth)	80 MHz
Number of carriers per pipe	Up to 4
Supported bandwidths	10, 15, 20 MHz

Interfaces

Figure 160 AZQE interfaces

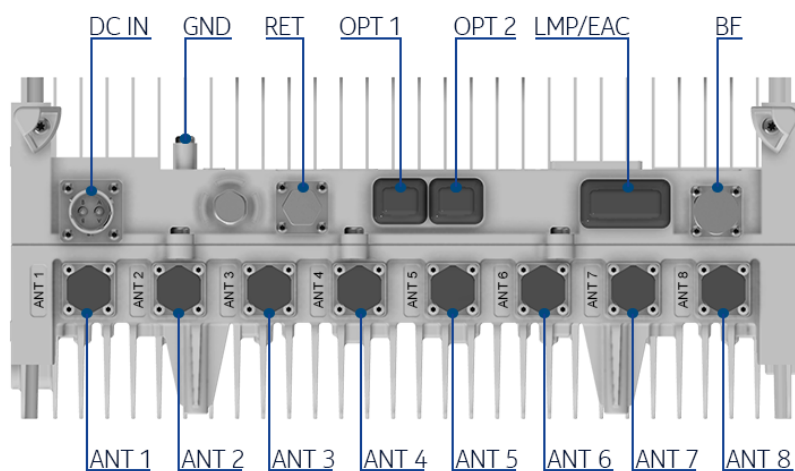

Table 554 AZQE interfaces

Interface	Label on the HW	Number of interfaces	Connector type	Additional info
Power Connector	DC IN	1	High power circular	APPB, APPC
Antenna connector	ANT	8	4.3-10	-
Remote Electrical Tilt	RET	1	8-pin circular	RS-485
External Alarm Connection	LMP/EAC	1	MDR26	-
Optical interface	OPT	2	SFP+	9.8 Gbps, CPRI; Nokia IP seal
Beamforming	BF	1	4.3-10	-
Grounding		1	M8 or dual M5 screws	-

Table 554 AZQE interfaces (Cont.)

Interface	Label on the HW	Number of interfaces	Connector type	Additional info
Fan	FAN	1	Nokia fan	Located on the opposite side



WARNING! Risk of electric shock

Before turning RF power on, RF ports have to be terminated by nominal 50Ω load (for example, feeder with antenna). However, if these conditions are not met, the plastic caps that are delivered within the unused RF ports should remain in place. The plastic caps isolate RF power from the environment, and thus provide electric shock security in case RF power is accidentally on.

Antenna Line Devices (ALDs) support

Table 555 AZQE ALD support

ALD support through RS-485 port	Value
AISG	2.0, 3.0
CWA (for non-AISG installations)	No
Voltage	14.5 V
Power per port	30 W

Functional block diagram

Figure 161 AZQE functional block diagram

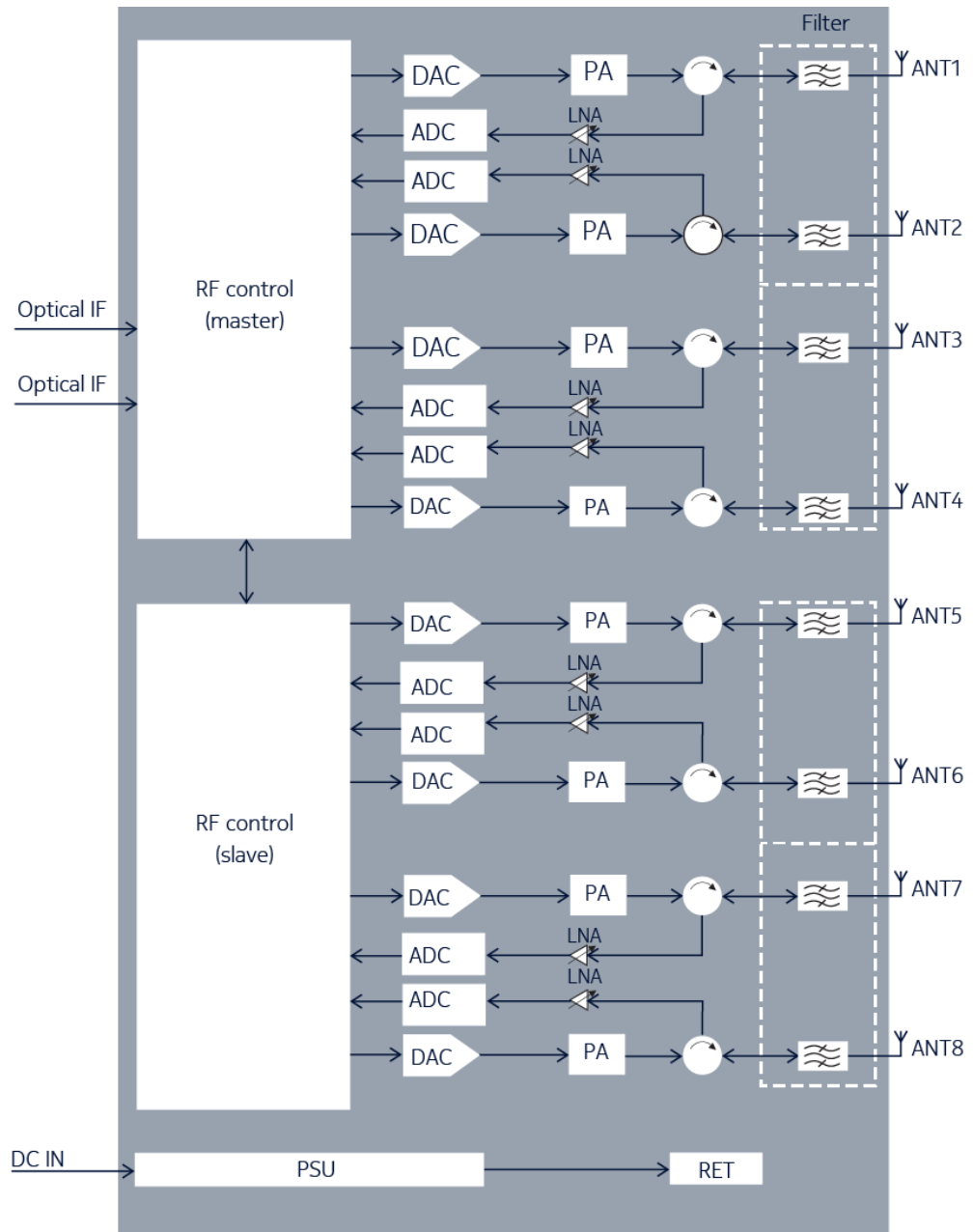

Electrical specifications

Table 556 AZQE electrical specifications

Property	Value
Nominal supply voltage	-48.0 V DC
Nominal input voltage range	-40.5 V DC to -57.0 V DC
Extended input voltage range	-36.0 V DC to -40.5 V DC -57.0 V DC to -60.0 V DC



Note: The minimum startup voltage is -40.5 V DC. If the input voltage is below/beyond extended limits, unit might shut down.

Power consumption

Typical power consumption [W] for 48VDC input, at 25°C, representative of typical product performance under the same conditions (HW variant, SW version, configuration, environment, and so on) with +/- 10% margin. Average = (6h low hour load, 10h medium hour load and 8h busy hour load) / 24h

Configurations explained on examples:

- GSM/WCDMA: 2/2/2 = three sectors, two carriers/TRXs per sector
- LTE:
 - o 2/2/2 2Tx = three sectors, two carriers per sector, 2Tx per carrier
 - o 1+1/1+1/1+1 4Tx = three dual-band sectors, one carrier per sector per band, 4Tx per carrier

Some radio units are capable of providing only one sector coverage. Then the power values in the table consider deployment of three radio units.

Table 557 AZQE power consumption in LTE mode

Configuration	Output power per carrier [W]	Power consumption (W) ETSI 202706 average load P _{RRH, static}	Power consumption (W) ETSI 202706 busy hour load P _{BH RRH, static}	Power consumption (W) 100% RF power load P _{100% RRH}
1/1/1 8Tx	8x30	1098	1415	2182
1/1/1 4Tx	4x30	698	847	1187
1/1/1 8Tx	8x20	932	1137	1590
1/1/1 4Tx	4x20	619	722	929



Note: Power consumption values are measured according to ETSI 202 706-1 v1.5 assumptions (subframe #2 and special subframe #7), leading to 74.3% TX duty cycle. Higher TX duty cycle causes higher power consumption.

Power reduction

Table 558 Recommended AZQE power reduction in 256 QAM

Carrier configuration	Power reduction [dB]
Multiple carriers, continuous	1
Multiple carriers, non-continuous	1.4
Single carrier	1



Note: The maximum power reduction (dlCellPwrRed) value is 20 dB. High power reduction values may cause radio outages.

Related optional items

- ASFD AirScale 2 TD RRH 8-pipe fan unit (474485A)
- AMGN AirScale 2 cover 395 x 150-175 (474535A)
- AMBG AirScale book mount kit 151-175 (474467A)
- FPKA Flexi Pole Mounting Kit (30-120 mm) (471649A)
- FPKC Flexi Pole Mounting Kit (60-300 mm) (472821A)
- AMPA Pole Mounting Kit (30-120 mm) (473879A)
- AMFA AirScale 2 FPKx fixing adapter (474289A)
- AMRB AirScale one clip bracket 126-200 (474581A)
- AMRC AirScale one clip rail 600 mm (474583A)
- ASAA AirScale 2 MDR26-open EAC cable 5 m (474288A)
- APPB AirScale 2 55A DC plug 3.3-10 mm² (474282A)
- APPC AirScale 2 55A DC plug 10-16 mm² (474283A)

Installation options

- Pole mounting
- Wall mounting
- Tower mounting
- Book mounting with optional fan
- One-clip rail installation



NOTICE: Install this RRH in a vertical orientation with connectors on the bottom side, to ensure convection cooling. For horizontal installation fans are required.

Dimensions and weight

Table 559 AZQE dimensions and weight

Property	Value	Dimensions orientation
Height	Core RRH: 385 mm (15.2 in.) With upper and lower mounting brackets: 469 mm (18.5 in.)	
Width	395 mm (15.6 in.)	
Depth	Core RRH: 170 mm (6.7 in.) With mounting brackets: 190.5 mm (7.5 in.)	
Weight	24.0 kg (52.0 lb)	

Environmental specifications

Table 560 AZQE environmental specifications

Property	Value
Maximum operational outdoor temperature (stand-alone outdoor pole or mast)	55°C (131°F)

Table 560 AZQE environmental specifications (Cont.)

Property	Value
Maximum operational indoor and outdoor temperature (wall and shelter)	45°C (113°F)
Maximum operational indoor and outdoor temperature (with optional fan)	55°C (131°F)
Minimum operational temperature	-40°C (-40°F)
IP rating	IP65

LTE3736 feature interdependencies

LTE3736: Nokia AirScale RRH 8T8R B42 240 W (AZQE) supports the following features:

- LTE112: Cell Bandwidth - 20 MHz needs to be enabled to use LTE 20 MHz carrier.
- LTE113: Cell Bandwidth - 15 MHz needs to be enabled to use LTE 15 MHz carrier.
- LTE114: Cell Bandwidth - 10 MHz needs to be enabled to use LTE 10 MHz carrier.
- With LTE614: Distributed Site AZQE can be used in distributed sites with up to 23 km fiber length to the system module.
- Power saving features:
 - LTE1103: Load based Power Saving for multi-layer networks
 - LTE1203: Load based Power Saving with Tx path switching off
 - LTE2508: BTS Embedded Power Meter for Energy Efficiency Monitoring
 - LTE3036: Micro DTX extension

7.8 Nokia AirScale RRH 8T8R B42 240 W (AZQF)

AZQF is introduced by LTE3737: Nokia AirScale RRH 8T8R B42 240W (AZQF).

Functional description

Table 561 AZQF functional specification

Property	Value
Output power	8x30 W
QAM	256 QAM (DL) 64 QAM (UL)
Number of TXRX	8T8R
Outdoor installation	Yes
Beamforming	Yes
Supported technologies (standalone and MSR)	TD-LTE
Frequency range	3410 - 3590 MHz
Filter bandwidth	180 MHz

Table 561 AZQF functional specification (Cont.)

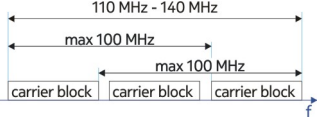
Property	Value
iBW (instantaneous bandwidth)	<p>140 MHz</p> <p>Carrier configuration depends on the iBW used:</p> <ul style="list-style-type: none"> • For iBW up to 110 MHz - any carrier configuration • For iBW over 110 MHz and up to 140 MHz the following requirements for carrier blocks must be fulfilled. A carrier block is a set of consecutive carriers. <ul style="list-style-type: none"> - The frequency distance between the lower edge of the lowest carrier block and the lower edge of the highest carrier block must be max 100 MHz - The frequency distance between the lower edge of the lowest carrier block and the lower edge of the highest carrier block must be max 100 MHz <p><i>Figure 162 AZQF carrier configuration for iBW from over 110 MHz to 140 MHz</i></p> 
oBW (occupied bandwidth)	80 MHz
Number of carriers per pipe	Up to 4
Supported bandwidths	10, 15, 20 MHz

Interfaces

Figure 163 AZQF interfaces

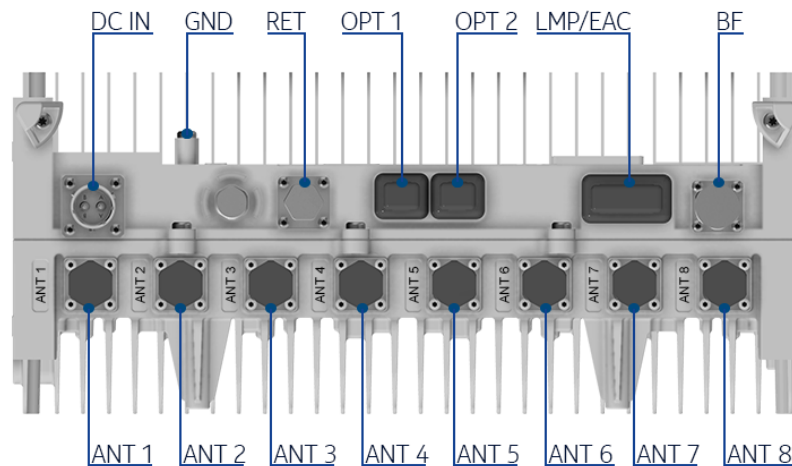



Table 562 AZQF interfaces

Interface	Label on the HW	Number of interfaces	Connector type	Additional info
Power Connector	DC IN	1	High power circular	APPB, APPC
Antenna connector	ANT	8	4.3-10	-
Remote Electrical Tilt	RET	1	8-pin circular	RS-485
External Alarm Connection	EAC	1	MDR26	-
Optical interface	OPT	2	SFP+	9.8 Gbps, CPRI; Nokia IP seal
Beamforming	BF	1	4.3-10	-
Grounding		1	2 x M5 screw	-
Fan	FAN	1	Nokia fan	Located on the opposite side



WARNING! Risk of electric shock

Before turning RF power on, RF ports have to be terminated by nominal 50Ω load (for example, feeder with antenna). However, if these conditions are not met, the plastic caps that are delivered within the unused RF ports should remain in place. The plastic caps isolate RF power from the environment, and thus provide electric shock security in case RF power is accidentally on.

Antenna Line Devices (ALDs) support

Table 563 AZQF ALD support

ALD support through RS-485 port	Value
AISG	2.0, 3.0
CWA (for non-AISG installations)	No
Voltage	14.5 V
Power per port	30 W

Functional block diagram

Figure 164 AZQF functional block diagram

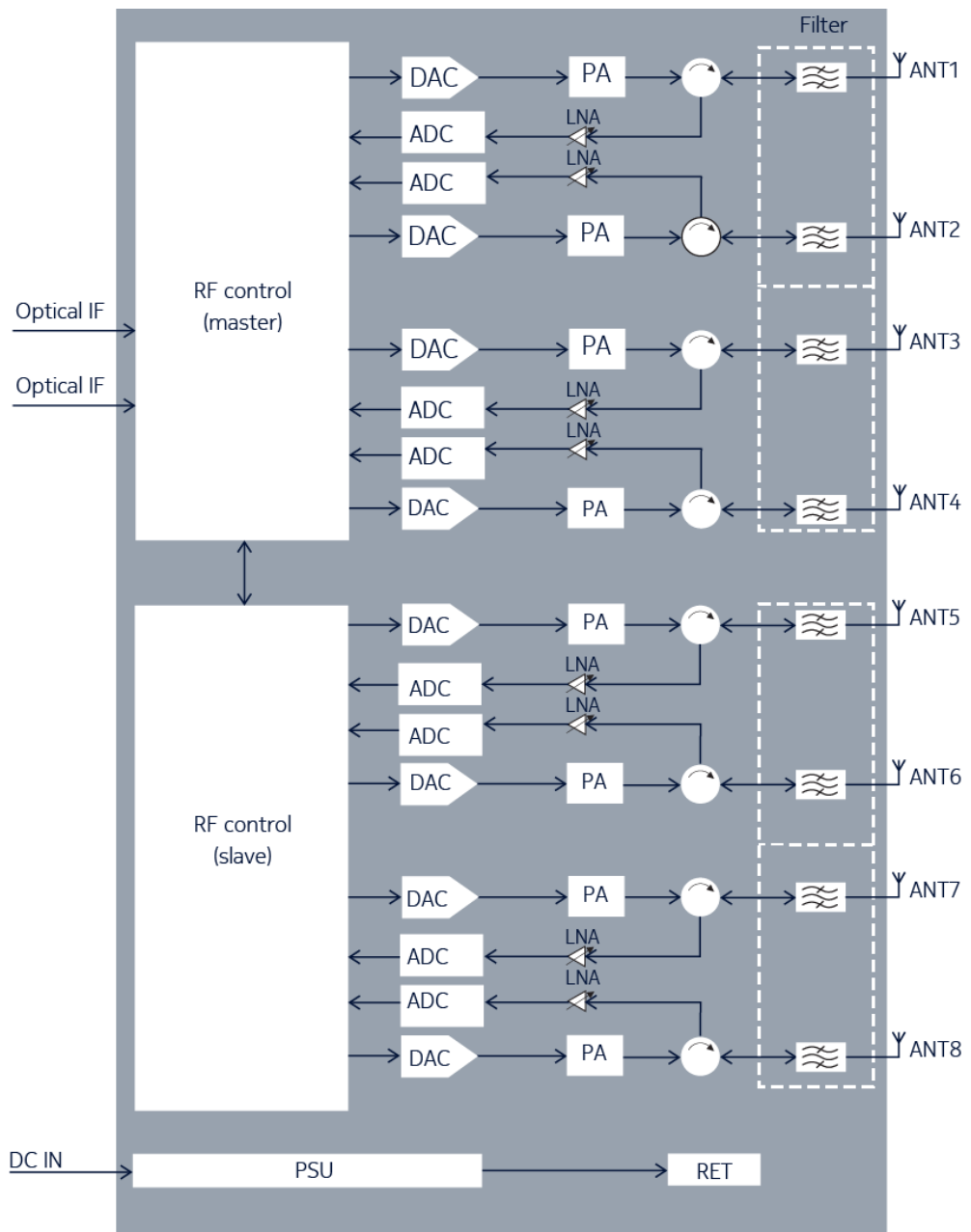

Electrical specifications

Table 564 AZQF electrical specifications

Property	Value
Nominal supply voltage	-48.0 V DC
Nominal input voltage range	-40.5 V DC to -57.0 V DC
Extended input voltage range	-36.0 V DC to -40.5 V DC -57.0 V DC to -60.0 V DC



Note: The minimum startup voltage is -40.5 V DC. If the input voltage is below/beyond extended limits, unit might shut down.

Power consumption

Typical power consumption [W] for 48VDC input, at 25°C, representative of typical product performance under the same conditions (HW variant, SW version, configuration, environment, and so on) with +/- 10% margin. Average = (6h low hour load, 10h medium hour load and 8h busy hour load) / 24h

Configurations explained on examples:

- GSM/WCDMA: 2/2/2 = three sectors, two carriers/TRXs per sector
- LTE:
 - o 2/2/2 2Tx = three sectors, two carriers per sector, 2Tx per carrier
 - o 1+1/1+1/1+1 4Tx = three dual-band sectors, one carrier per sector per band, 4Tx per carrier

Some radio units are capable of providing only one sector coverage. Then the power values in the table consider deployment of three radio units.

Table 565 AZQF power consumption in LTE mode

Configuration	Output power per carrier [W]	Power consumption ETSI 202706 average P _{RRH, static}	Power consumption ETSI 202706 busy hour load P _{BH RRH, static}	Power consumption 100% RF power load P _{100% RRH}
1/1/1 8Tx	8x30	1118	1439	2137
1/1/1 4Tx	4x30	710	863	1186
1/1/1 8Tx	8x20	950	1160	1587
1/1/1 4Tx	4x20	629	734	938



Note: Power consumption values are measured according to ETSI 202 706-1 v1.5 assumptions (subframe #2 and special subframe #7), leading to 74.3% TX duty cycle. Higher TX duty cycle causes higher power consumption.

Power reduction

Table 566 Recommended AZQF power reduction in 256 QAM

Carrier configuration	Power reduction [dB]
Multiple carriers, continuous	1.3
Multiple carriers, non-continuous	1.7
Single carrier	1



Note: The maximum power reduction (`dlCellPwrRed`) value is 20 dB. High power reduction values may cause radio outages.

Related optional items

- ASFD AirScale 2 TD RRH 8-pipe fan unit (474485A)
- AMGN AirScale 2 cover 395 x 150-175 (474535A)
- AMBG AirScale book mount kit 151-175 (474467A)
- FPKA Flexi Pole Mounting Kit (30-120 mm) (471649A)
- FPKC Flexi Pole Mounting Kit (60-300 mm) (472821A)
- AMPA Pole Mounting Kit (30-120 mm) (473879A)
- AMFA AirScale 2 FPKx fixing adapter (474289A)
- AMRB AirScale one clip bracket 126-200 (474581A)
- AMRC AirScale one clip rail 600 mm (474583A)
- ASAA AirScale 2 MDR26-open EAC cable 5 m (474288A)
- APPB AirScale 2 55A DC plug 3.3-10 mm² (474282A)
- APPC AirScale 2 55A DC plug 10-16 mm² (474283A)

Installation options

- Pole mounting
- Wall mounting
- Tower mounting
- Book mounting with optional fan
- One-clip rail installation



NOTICE: Install this RRH in a vertical orientation with connectors on the bottom side, to ensure convection cooling. For horizontal installation fans are required.

Dimensions and weight

Table 567 AZQF dimensions and weight

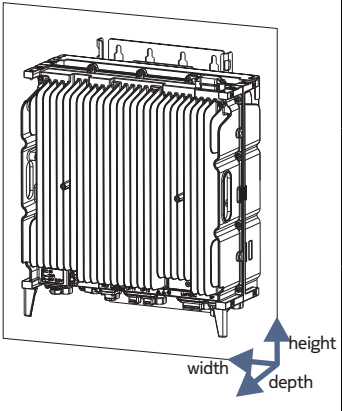
Property	Value	Dimensions orientation
Height	Core RRH: 385 mm (15.2 in.) With upper and lower mounting brackets: 469 mm (18.5 in.)	
Depth	Core RRH: 170 mm (6.7 in.) With mounting brackets: 190.5 mm (7.5 in.)	
Width	395 mm (15.6 in.)	
Weight	22.5 kg (49.6 lb)	

Environmental specifications

Table 568 AZQF environmental specifications

Property	Value
Maximum operational outdoor temperature (stand-alone outdoor pole or mast)	55°C (131°F)
Maximum operational indoor and outdoor temperature (wall and shelter)	45°C (113°F)
Maximum operational indoor and outdoor temperature (with optional fan)	55°C (131°F)
Minimum operational temperature	-40°C (-40°F)
IP rating	IP65

LTE3737 feature interdependencies

LTE3737: AirScale RRH 8T8R B42 240W AZQF supports the following features:

- With LTE614: Distributed Site AZQF can be used in distributed sites with up to 23 km fiber length to the system module.
- LTE3036: Micro DTX extension
- LTE2508: BTS Embedded Power Meter for Energy Efficiency Monitoring
- LTE1103: Load based Power Saving for multi-layer networks
- LTE1203: Load based Power Saving with Tx path switching off

8 Nokia AirScale Radio Units sound power levels

Sound power levels measured according to ISO 3744

Table 569 Nokia AirScale RRH sound power levels (measured according to ISO 3744)

Configuration	Without fans	Maximum with optional fans
Single module with fan	0 dBA	51 dBA
Three modules with fans	0 dBA	61 dBA

Table 570 Nokia AirScale 2 300 RRH sound power levels (measured according to ISO 3744)

Configuration	Without fans	Maximum with optional fans
Single module with optional fans @ 15°C (59°F)	0 dBA	54 dBA
Single module with optional fans @ 23°C (73.4°F)	0 dBA	58 dBA
Single module with optional fans @ 45°C (113°F)	0 dBA	63 dBA

Table 571 Nokia AirScale 2 600 RRH sound power levels (measured according to ISO 3744)

Configuration	Without fans	Maximum with optional fans
Single module with optional fans @ 15°C (59°F)	0 dBA	57 dBA for 160 W radios
	0 dBA	59 dBA for 240 W radios
	0 dBA	60 dBA for 320 W radios
Single module with optional fans @ 23°C (73.4°F)	0 dBA	61 dBA for all radios
Single module with optional fans @ 50°C (122°F)	0 dBA	66 dBA for 160 W radios
	0 dBA	67 dBA for 240 W and 320 W radios

9 Nokia AirScale Radios LED indicators

Remote Radio Head and RF Module LEDs.

Table 572 LEDs for RF Modules

LED color	Description	Alarm
Red, stable	Critical alarm affecting the whole RF module or all antenna carriers	Fault
Red, blinking	Operation degraded <ul style="list-style-type: none"> Major alarm affecting the whole RF Module Major alarm affecting the whole RF Module Major/Critical alarm affecting a module subcomponent or antenna carrier 	Major/critical alarm
Yellow, stable	<ul style="list-style-type: none"> Until software download begins The carriers are blocked from BTS There is no connection to any System Module 	No alarm
Yellow, blinking	<ul style="list-style-type: none"> Software download in progress Configuration in progress: RF resources are being setup, but not yet activated 	No alarm
Green, stable	<ul style="list-style-type: none"> Software configuration is complete or supervisory: RF resources activated and transmission is possible Working normally, no alarm on the RF Module 	No alarm
Green, blinking	Software downloading and updating	No alarm
Stable Red for less than 5 seconds and changes to Stable Yellow	Switched ON, but the next conditions are not reached yet	No alarm
Stable Red for less than 5 seconds	The module is in the process of resetting	No alarm
Periodic Red and Green	Antenna line faulty/degraded due to external factors (for example, VSWR minor/major values exceeded, Antenna line device faulty/degraded)	Alarm

Table 572 LEDs for RF Modules (Cont.)

LED color	Description	Alarm
Blinking Colors (Red, Yellow, and Green), each color stable for 0.5 second	Module highlighting (Flexi BTS SM functionality that can help identifying faulty module)	No alarm
RF Module fan/TX status LED: Red	At least one fan is faulty or degraded	
RF Module fan/TX status LED: Green	All fans are working	
RF Module fan/TX status LED: Color set according to fan status, stable	RF transmission is ON	
RF Module fan/TX status LED: Color set according to fan status, blinking	RF transmission is OFF	

Table 573 LEDs for RRHs

LED color	Description	Alarm
Red, stable	Critical alarm affecting the whole RF module or all antenna carriers	Fault
Red, blinking	Operation degraded <ul style="list-style-type: none"> Major alarm affecting the whole RF Module Critical alarm affecting fans Major/Critical alarm affecting a module subcomponent or antenna carrier 	Major/critical alarm
Yellow, stable	<ul style="list-style-type: none"> Until software download begins The carriers are blocked from BTS There is no connection to any System Module 	No alarm
Yellow, blinking	<ul style="list-style-type: none"> Software download in progress Configuration in progress: RF resources are being setup, but not yet activated 	No alarm
Green, stable	<ul style="list-style-type: none"> Software configuration is complete or supervisory: RF resources activated and transmission is possible Working normally, no alarm on the RF Module 	No alarm

Table 573 LEDs for RRHs (Cont.)

LED color	Description	Alarm
Green, blinking	Software downloading and updating	No alarm
Stable Red for less than 5 seconds and changes to Stable Yellow	Switched ON, but the next conditions are not reached yet	No alarm
Stable Red for less than 5 seconds	The module is in the process of resetting	No alarm
Periodic Red and Green	Antenna line faulty/degraded due to external factors (for example, VSWR minor/major values exceeded, Antenna line device faulty/degraded)	Alarm
Blinking Colors (Red, Yellow, and Green), each color stable for 0.5 second	Module highlighting (Flexi BTS SM functionality that can help identifying faulty module)	No alarm



Note: FHEL, FRIJ, FHDI, FHPD and FHKA radios do not support critical alarm affecting fans led.

10 Avoiding Passive Intermodulation during RF Module and RRH operation

In wideband frequencies, when several transmitting and receiving signals are sharing the same hardware, Passive Intermodulation (PIM) Interference could be noted. Using RF Modules might cause a potential risk of generating third-order intermodulation that results in distortions in the receiver (RX) channel. Antenna Line Devices (ALD) have an important role in preventing Passive Intermodulation generation, even if the used RF Module and RRH performance at the antenna connector complies with 3GPP requirements.

Poor PIM performance of ALD might degrade significantly the reference sensitivity. ALDs, like MHAs, provided by Nokia have high PIM requirements.

The risk might be high in the following cases:

- maximum bandwidth (BW) used for the carriers is more than 0.5 x duplex separation of the band
- carriers in configuration are wideband in nature (for example WCDMA or LTE), or combination of wideband and narrow band carriers (for example RF sharing GSM-WCDMA or GSM-LTE).
- antenna line PIM performance is poor, or not on the required level for the configuration.

Table 574 Typical reference sensitivity degradation with different Antenna line PIM performance.

PIM performance	Typical degradation	Note
-140 dBc @ 2x43 dBm	~10 dB	High degradation, carrier configuration unusable in many cases
-153 dBc @ 2x43 dBm	~2 dB	Modest degradation, tolerable in many cases
-161 dBc @ 2x43 dBm	~0.2 dB	Minimal degradation, however, difficult to reach on the typical site environment.

When using wideband carrier configurations where PIM products fall into own receiver band, it is recommended that antenna line PIM performance is at least -153 dBc measured with 2 x 43dB test signals.

However, this kind of performance might be very difficult to achieve and maintain over time in outdoor environment due to mechanisms behind the PIM including corrosion, oxidation, material imperfections, and defects in workmanship. Some of these parameters might change, and can degrade performance during operation. Taking that into consideration, it is highly recommended not to use carrier configurations which are generating intermodulation results in landing in own receiver channels.